

## PERFORMANCE EVALUATION OF HYDROCYCLONE FILTER FOR MICROIRRIGATION

DAMODHARA R. MAILAPALLI<sup>1</sup>, PATRICIA A. A. MARQUES<sup>2</sup>,  
KOCHUKALEPKAL J. THOMAS<sup>3</sup>

**ABSTRACT:** In this study a hydrocyclone filter of 20 cm was selected and its performance was evaluated by studying the variation of discharge, pressure drop, influent concentration, and filtration efficiency with elapsed time of operation. The filter was tested with clean water to determine clean pressure drop and later it was tested with four concentrations of solid suspension, viz. 300; 600; 900 and 1,200 mg L<sup>-1</sup>. In the concentration of 300 mg L<sup>-1</sup>, the variation of pressure drop was low. But for the other concentrations of solid suspension, the variation was significant. The maximum pressure drops obtained were 41.19, 45.11, 50.01 and 52.95 kPa at 350, 390, 280 and 190 minutes of elapsed time, respectively. The maximum efficiency of solid suspension was 30.3, 32.96, 43.89 and 52.5% where as the minimum efficiencies were 9.91, 9.93, 9.62 and 9.9%, respectively. The hydrocyclone tested presented inefficiency to filter small particles as clay. The initial removal efficiency of higher concentration was bigger than for lower concentration but, the final efficiency are almost the same irrespective of the concentration of solid suspension. The present tested hydrocyclone could be used as a pre-filter microirrigation to prevent emitter clogging.

**KEYWORDS:** clogging, filtration efficiency, solid suspension.

## AVALIAÇÃO DO DESEMPENHO DE FILTRO HIDROCICLONE PARA A IRRIGAÇÃO LOCALIZADA

**RESUMO:** Neste estudo, avaliou-se o desempenho de um filtro hidrociclone de 20 cm pelo estudo da variação de vazão, queda de pressão, concentração na alimentação e eficiência de filtração com o tempo de operação do filtro. O filtro foi testado com água limpa para determinar a queda de pressão e depois foi testado com quatro concentrações de suspensão do solo de 300; 600; 900 e 1.200 mg L<sup>-1</sup>. No caso de 300 mg L<sup>-1</sup>, a variação da queda de pressão foi baixa. Para as outras concentrações de suspensão de sólidos, a variação foi expressiva. A máxima queda de pressão obtida foi de 41,19; 45,11; 50,01 e 52,95 kPa aos 350; 390; 280 e 190 minutos de operação, respectivamente. As máximas eficiências para as concentrações de sólidos suspensos foram de 30,3; 32,96; 43,89 e 52,5%, onde as mínimas eficiências foram de 9,91; 9,93; 9,62 e 9,9%, respectivamente. O hidrociclone testado apresentou ineficiência para filtrar pequenas partículas, como argila. A eficiência inicial de remoção para altas concentrações foi maior quando comparada às obtidas para baixas concentrações, mas as eficiências finais são independentes da concentração da suspensão de sólidos. O hidrociclone testado é apropriado para ser usado como pré-filtro na irrigação localizada para prevenir entupimentos por partículas sólidas.

**PALAVRAS-CHAVE:** entupimento, eficiência de filtragem, sólidos em suspensão.

<sup>1</sup> Research Scholar, Department of Agriculture and Food Engineering, Indian Institute of Technology, Kharagpur-721 302, West Bengal, India, Phone: +91-9434368962, damdhar@agfe.iitkgp.ernet.in

<sup>2</sup> Eng<sup>a</sup> Agrônoma, Profa. Dra., Universidade do Oeste Paulista (UNOESTE), Presidente Prudente - SP, pmarques@unoeste.br

<sup>3</sup> Dean, Kelappaji College of Agricultural Engineering and Technology, Tavanur-679 573, Malappuram (Dt), Kerala, India.

Recebido pelo Conselho Editorial em: 1<sup>o</sup> -12-2005

Aprovado pelo Conselho Editorial em: 4-5-2007

## INTRODUCTION

The success of microirrigation depends on the ability of the system to prevent emitter clogging. Emitters with small orifices are used to deliver the required low flow rates and these small orifices can easily be clogged by particulate matter, biological growths, chemical precipitates or combination of these present in irrigation water. ADIN & SACKS (1991) reported that the suspended particles of size ranging from 60  $\mu\text{m}$  to 300  $\mu\text{m}$  are the major factor in the clogging of emitters. NAKAYAMA & BUCKS (1991) observed that the plastic cuttings originated from the sawing of the pipe during the installation and presence of oil and grease particles from leakage of bearing seals of well and booster pumps, that are in direct contact with the drip system are some of the causes of emitter plugging. Clogged or partially clogged emitters reduce the uniformity of water and nutrient application, thus reducing the uniformity of plant growth and the yield. A properly designed microirrigation system must have provisions to prevent emitter clogging. These provisions may include water quality analysis to identify the severity of the clogging problem, physical control of water by a filtration system and aeration/settling ponds, chemical treatment and biological control of irrigation water. Of which, physical control of water is mostly practiced to remove sand, silt and clay particles from irrigation water. The particles larger than about  $1/10^{\text{th}}$  of the size of the emitter orifice or flow passage should be removed using a proper filtration system to prevent particles from jamming. Without their removal, materials will settle out and deposit as sediments where the water velocity is low and causes emitter plugging (SCHWANKL et al., 1996).

Filters constitute a key and an expensive component in microirrigation systems. The most commonly and commercially available microirrigation filters are screen, media, hydrocyclone and disc type filters. Of these filters, the hydrocyclones, sand separators or centrifugal filters are very popular because they are reasonably inexpensive, simple to build and have no moving parts that can wear out or break. The basic separation principle employed in hydrocyclone filter is centrifugal sedimentation. These filters remove suspended particles that have a specific gravity higher than water. They can perform continuous separation and require minimum area. These filters are selected based on their flow rates which are generally operated at a pressure loss of 35 to 69 kPa. Researchers on various papers have reported the performance of hydrocyclone filters (VALLEBUONA et al., 1995; ROVINSKY, 1995; KILMA & KIM, 1996; AVEROUS & FUENTES, 1997; PATIL & RAO, 1999; CHEN et al., 2000; PUPRASERT et al., 2004; SOCCOL et al., 2005). But very little research has been done on hydrocyclones as water filtration device in the field of microirrigation.

SRIVASTAVA et al. (1998) studied the hydraulic performance of commercially available drip irrigation hydrocyclone filter of 8" for various sets of discharge vs. pressure drop for two concentration of solid suspension i.e. 600 and 1200  $\text{mg L}^{-1}$ . They found that the initial removal efficiency of higher concentration was more than lower concentration but final removal efficiency was not very much affected by the concentration of solid suspension. The performance of the hydrocyclone filter with respect to the amount of sediment load present in irrigation water has to be studied for proper selection of a filter. CHAUHAN (1998) suggested two main issues involving in testing hydraulic performance of filters. These are determination of clean pressure drop and determination of filtration efficiency. Therefore, an attempt has been made in the present study to evaluate the performance of the hydrocyclone filter with clean water and known concentration of impurities. The performance of the filter is studied by variation of discharge, pressure drop, influent and effluent concentrations, and filtration efficiency with time of operation of the filter.

## MATERIAL AND METHODS

In this study, a Rietema type hydrocyclone (JHF025) filter of 0.20 m was used as test filter. The Figure 1 show a sectional and a side view of the hydrocyclone. The filter is made up of pre treated mild steel coated with epoxy polyester powder in deep blue color using electrostatic powder coating method from inside and outside for protection against corrosion, weather effects and chemicals. The technical specifications of the JHF025 filter are given in Table 1.

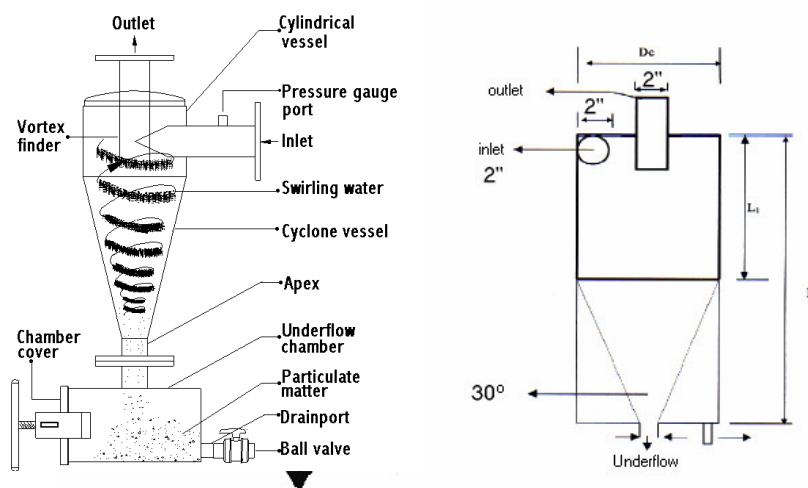

FIGURE 1. Sectional view of hydrocyclone filter (A) and a side view (B).

TABLE 1. Technical specifications of the JHF025 hydrocyclone filter.

Item	Parameter	Specification
1	Height of the filter	0.915 m
2	Inlet height	0.720 m
3	Diameter	0.220 m
4	Length of the filter	0.250 m
5	Length of vortex finder	0.220 m
6	Inlet/outlet diameter	0.0508 m
7	Weight	29 kg
8	Nominal size	0.0508 m
9	Cone angle	30°
10	Nominal flow rate	25 m <sup>3</sup> h <sup>-1</sup>
11	Min. operating flow rate	10 m <sup>3</sup> h <sup>-1</sup>
12	Max. operating pressure	980 kPa
13	Max. operating pressure drop	58.84 kPa
14	Min. operating pressure drop	9.81 kPa

The hydrocyclone filter was tested by studying the variation of clean pressure drop with flow rate and variation of pressure drop, discharge, influent concentration and filtration efficiency with elapsed time. Clean pressure drop is the pressure drop obtained across the inlet and outlet of the hydrocyclone filter when clean water is fed through it. The clean pressure drop was measured according to IS 14743:1999 recommendations (BUREAU OF INDIAN STANDARDS, 1999).

Experiments were carried out with four known concentrations of solid suspension, viz. 300; 600; 900 and 1,200 mg L<sup>-1</sup>, at the Hydraulics Laboratory of Kelappaji College of Agricultural Engineering and Technology, Tavanur, Kerala, India. The filter was tested for ten hours using recirculated irrigation water that was prepared with known amount of solid. The hydrocyclone filter was installed on a metallic frame to facilitate less vibration caused due to swirling of water (Figure 2).

A 3 hp centrifugal pump having 20 m hydraulic head was used to pump the known concentration of muddy water prepared in a sump (length, 5.85 m; width, 1.4 m; and depth, 0.86 m) through the hydrocyclone filter. The delivery point of the 3 hp centrifugal pump was connected to the inlet flange of the hydrocyclone filter with a PVC pipe of 0.0508 m diameter. Near the pump delivery, an outlet pipe was provided for collecting the influent samples of initial concentration at regular time intervals.

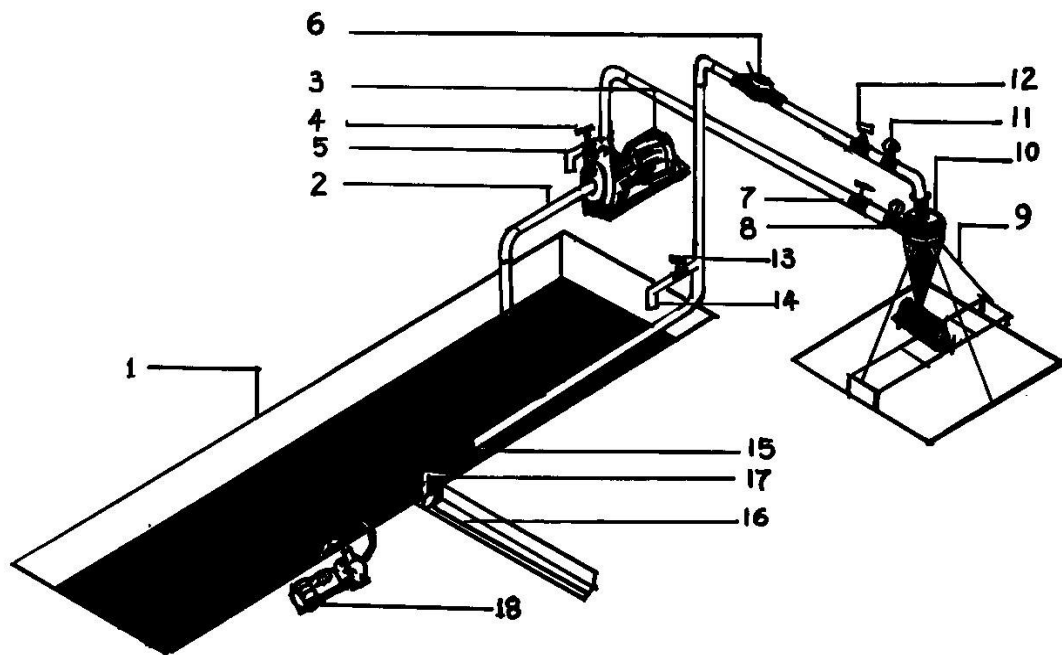

## Legend

- |   |   |
|---|---|
| 1. Sump                                     | 10. Hydrocyclone Filter                       |
| 2. Suction                                  | 11. Outlet Pressure Gauge $P_2$ ( $\pm 2\%$ ) |
| 3. 3hp CF Pump                              | 12. Gate Valve ( $G_3$ )                      |
| 4. Gate valve ( $G_1$ )                     | 13. Gate Valve ( $G_4$ )                      |
| 5. Inlet Sample Collection Point            | 14. Outlet Sample Collection Point            |
| 6. Water Meter ( $\pm 3\%$ )                | 15. Delivery                                  |
| 7. Gate Valve ( $G_2$ )                     | 16. Water Source                              |
| 8. Inlet Pressure Gauge $P_1$ ( $\pm 2\%$ ) | 17. 75 micron Sieve                           |
| 9. Supporting Frame                         | 18. 1.5 hp Pump                               |

FIGURE 2. Schematic view of the experimental setup.

The sampling process was controlled by fitting a gate valve to the outlet pipe. Near the inlet point of the hydrocyclone filter, a gate valve and a pressure gauge were provided to control the inflow rate and to monitor the inlet water pressure, respectively. The outlet of the hydrocyclone filter was directed to the sump using a PVC pipe of 0.0508 m diameter. The outlet pipe consisted of a pressure gauge, a gate valve and a water meter to measure the water pressure, to control the flow and outflow discharge, respectively. The two gate valves on either side of the hydrocyclone filter were used to provide sufficient pressure difference inside the cyclone chamber. Outflow samples were collected from an outlet provided near the outlet pipe. The sampling process was controlled by fitting a gate valve to the outlet. A centrifugal pump of 1.5 hp was used to stir the solid suspension in the sump. Both suction and delivery of the 1.5 hp pump were immersed in the sump. Tap water passing through a 200 micron sieve was used as source of clean water to the sump (BUREAU OF INDIAN STANDARDS, 1999). The capacity of the sump for each concentration was fixed to 5 m<sup>3</sup>. The sump was cleaned well and tap water through 200 micron sieve was used to fill the sump up to 0.61 m height to make the sump capacity, 5 m<sup>3</sup>. Then, the sump was covered with a plastic sheet to prevent entry of foreign particles into it. Before conducting the experiment, the hydrocyclone filter was properly cleaned by pumping the clean water using 3 hp pump. During the cleaning process, the gate valves at the sample collection points were closed and the gate valves at inlet and outlet of the hydrocyclone filter were opened fully.

The filter was tested first with clean water to determine the clean water pressure drop at inlet and outlet of the hydrocyclone filter. Known concentration of solid suspension, i.e., 300; 600; 900

and  $1,200 \text{ mg L}^{-1}$  were prepared by mixing 1.5; 2.0; 3.5 and 4 kg of field solid in to  $5 \text{ m}^3$  of clean water present in the sump. The field solid was dried and sieved through 2 mm-size sieve. The solid particles of size larger than 2 mm were not taken in the present study to simulate irrigation water and to avoid the wearing to the impeller of the 3 hp pump. A 1.5 hp centrifugal pump was used to mix the suspension continuously for ten hours of the experiment. After one hour of thorough mixing of the solid suspension with the small pump (1.5 hp), the experiment was started with an inlet flow rate of  $20 \text{ m}^3 \text{ h}^{-1}$ . The gate valve at the outlet flange of hydrocyclone filter was partially closed to achieve the maximum inlet pressure at the inlet pressure gauge. Observations, such as inlet pressure, outlet pressure, and water meter readings were noted at every five-minute interval. Similarly, samples from the influent and effluent were collected in plastic containers of capacity 500 mL each, from the inlet and outlet points. After completion of one batch of concentration, the sump was cleaned and filled with clean water and another concentration was prepared to test.

## RESULTS AND DISCUSSION

The final values of the experiment are presented and argued in the following. The variation of clean pressure drop with the flow rate is given in the Figure 3.

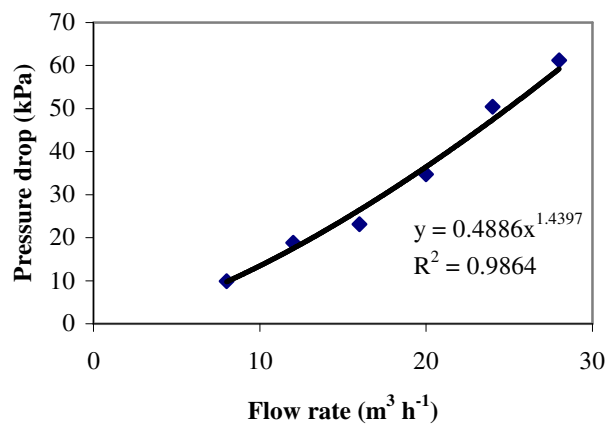

FIGURE 3. Variation of clean pressure drop with the flow rate.

It can be observed from Figure 3 that pressure drop for clean water increases with increased inflow rate (feed rate). When the inlet feed rate increases, the tangential velocity of flow in the hydrocyclone increases. Thereby the centrifugal force on water molecules increases and gives high radial velocity. This may create enough turbulent kinetic energy in the cyclone, which can be seen as pressure drop across the filter. It was found that the clean pressure drop varies 1.44 to the power of flow rate as shown in the following empirical equation 1.

$$\Delta p = 0.4886 Q_i^{1.4397} \quad (1)$$

where,

$\Delta p$  - clean pressure drop, kPa, and  
 $Q_i$  - inflow rate or feed rate,  $\text{m}^3 \text{ h}^{-1}$ .

The variation of head loss build up with elapsed time is presented in Figure 4, for the four concentrations of solid suspension viz. 300, 600, 900 and  $1200 \text{ mg L}^{-1}$ .

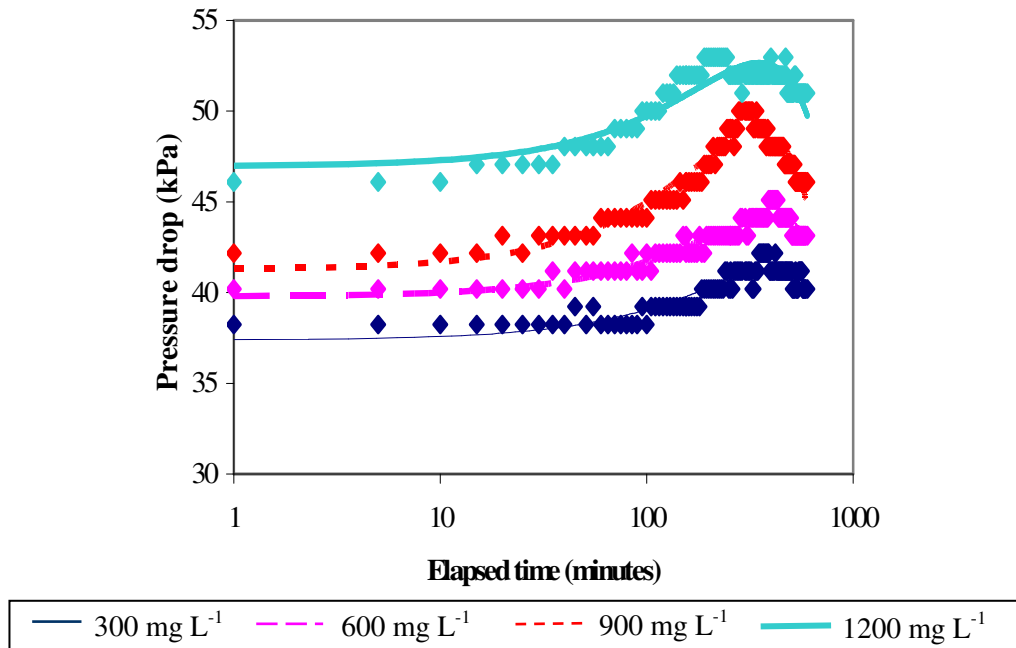

FIGURE 4. Variation of pressure drop with elapsed time for four concentrations of solid suspension for 20 m<sup>3</sup> h<sup>-1</sup> inflow rate.

It was observed (Figure 4) that the pressure drop increased for certain elapsed time and then decreased. It may be the fact that the highly concentrated water at initial stages causes more turbulence in the cyclone filter and thus the radial velocity increases. The increased radial velocity may cause the additional load on inlet of the cyclone to increase the inlet pressure. The increase in inlet pressure causes increase in pressure drop. The decreased pressure drop during some elapsed time may be attained due to the decrease of influent concentration. The cleaner the liquid going to the hydrocyclone, lesser the turbulence will be, and thus the lower will be the load on cyclone inlet. The lesser load on inlet may cause decreased inlet pressure and, therefore, the pressure drop may decrease. As the particulate matter is less in the case of 300 mg L<sup>-1</sup> concentration, the variation of pressure drop is not much. But for the other concentrations of solid suspension, the variation is significant. The maximum pressure drops obtained for 300; 600; 900 and 1,200 mg L<sup>-1</sup> solid suspension are 41.19; 45.11; 50.01 and 52.95 kPa at 350; 390; 280 and 190 min of elapsed time, respectively. The empirical relationships (equations 2; 3; 4 and 5) obtained from the graph are as follows.

$$\Delta p = -2 \times 10^{-05} t^2 + 0.0191 t + 37.396 \quad R^2 = 0.8292 \text{ for } 300 \text{ mg L}^{-1} \text{ solid suspension} \quad (2)$$

$$\Delta p = -3 \times 10^{-05} t^2 + 0.022 t + 39.788 \quad R^2 = 0.8848 \text{ for } 600 \text{ mg L}^{-1} \text{ solid suspension} \quad (3)$$

$$\Delta p = -6 \times 10^{-05} t^2 + 0.0435 t + 41.264 \quad R^2 = 0.9062 \text{ for } 900 \text{ mg L}^{-1} \text{ solid suspension} \quad (4)$$

$$\Delta p = -5 \times 10^{-05} t^2 + 0.0324 t + 46.972 \quad R^2 = 0.8148 \text{ for } 1,200 \text{ mg L}^{-1} \text{ solid suspension} \quad (5)$$

where,

$\Delta p$  - clean pressure drop, kPa, and

t - elapsed time, minutes.

The variation of discharge with elapsed time is presented in Figure 5.

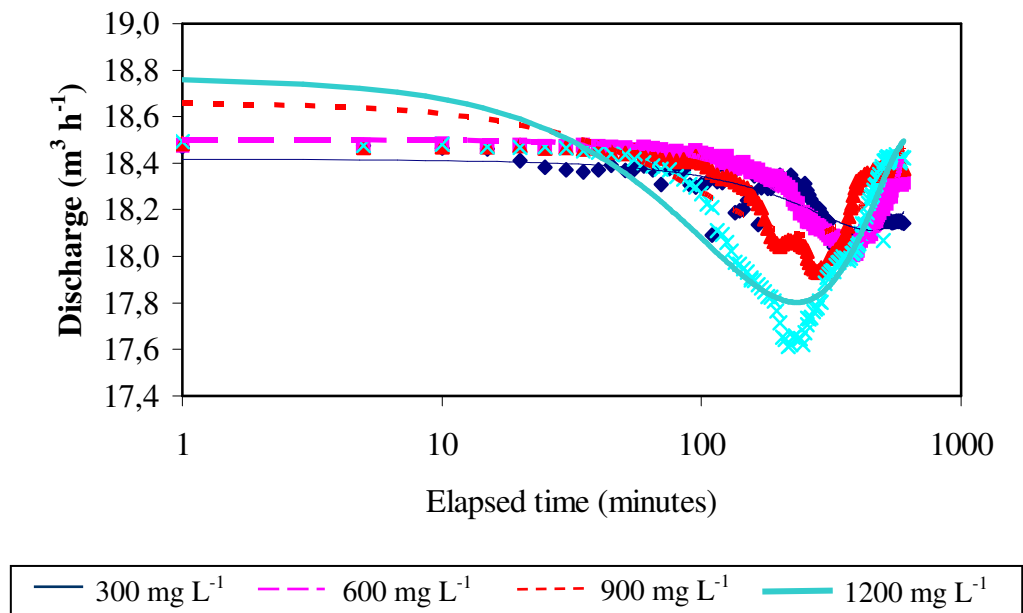

FIGURE 5. Variation of discharge with elapsed time for four concentrations of solid suspension.

It is noted that the discharge decreases for some elapsed time and then it increases. The decrease in discharge may be due to increase in pressure drop during the elapsed time. The discharge again increases slightly due to decrease in pressure drop with elapsed time. The decrease in pressure drop may be due to decrease in concentration of influent. The initial discharges for all four concentrations of solid suspension are almost same i.e.  $18.47 \text{ m}^3 \text{ h}^{-1}$ , and the final discharges after ten hours of operation for 300; 600; 900 and  $1,200 \text{ mg L}^{-1}$  solid suspension are  $18.11$ ;  $18.30$ ;  $18.36$  and  $18.40 \text{ m}^3 \text{ h}^{-1}$ , respectively. The empirical relationships between these two parameters are given below in the equations (6; 7; 8 and 9).

$$Q = 4 \times 10^{-9} t^3 - 2 \times 10^{-6} t^2 - 0.0006 t + 18.417 \quad R^2 = 0.7399 \text{ for } 300 \text{ mg L}^{-1} \text{ solid suspension} \quad (6)$$

$$Q = 1 \times 10^{-8} t^3 - 7 \times 10^{-6} t^2 - 0.0002 t + 18.501 \quad R^2 = 0.9312 \text{ for } 600 \text{ mg L}^{-1} \text{ solid suspension} \quad (7)$$

$$Q = -1 \times 10^{-8} t^3 + 1 \times 10^{-5} t^2 - 0.0052 t + 18.664 \quad R^2 = 0.7245 \text{ for } 900 \text{ mg L}^{-1} \text{ solid suspension} \quad (8)$$

$$Q = -2 \times 10^{-8} t^3 + 3 \times 10^{-5} t^2 - 0.0095 t + 18.768 \quad R^2 = 0.8791 \text{ for } 1200 \text{ mg L}^{-1} \text{ solid suspension} \quad (9)$$

where,

Q - discharge ( $\text{m}^3 \text{ h}^{-1}$ ), and

t - elapsed time, minutes

The variation of the influent concentration with elapsed time is presented in Figure 6.

The influent concentration (Figure 6) is decreasing in an increasing rate for some time and then it remains constant. The constant concentration indicates the inefficiency of the filter for small particulate matter like clay. In the case of  $300 \text{ mg L}^{-1}$  solid suspension, the decrease in concentration is less compared to the other concentrations. In the case of  $1,200 \text{ mg L}^{-1}$  the influent concentration is reduced rapidly and then it is maintained constant. The initial concentration of the influent of 300; 600; 900 and  $1,200 \text{ mg L}^{-1}$  are 296.3; 597.34; 896.78 and  $1,190.67 \text{ mg L}^{-1}$ , respectively. The concentrations after ten hours of operation of the filter are 69.69; 69.18; 91.16 and  $122.38 \text{ mg L}^{-1}$ , respectively. The final concentration of the  $1,200 \text{ mg L}^{-1}$  was high when compared to the other concentrations. When the concentration is high, some times due to high turbulence, re-suspension of the particles may take place and they may escape as over flow. Therefore, finer separation there may not have been achieved.

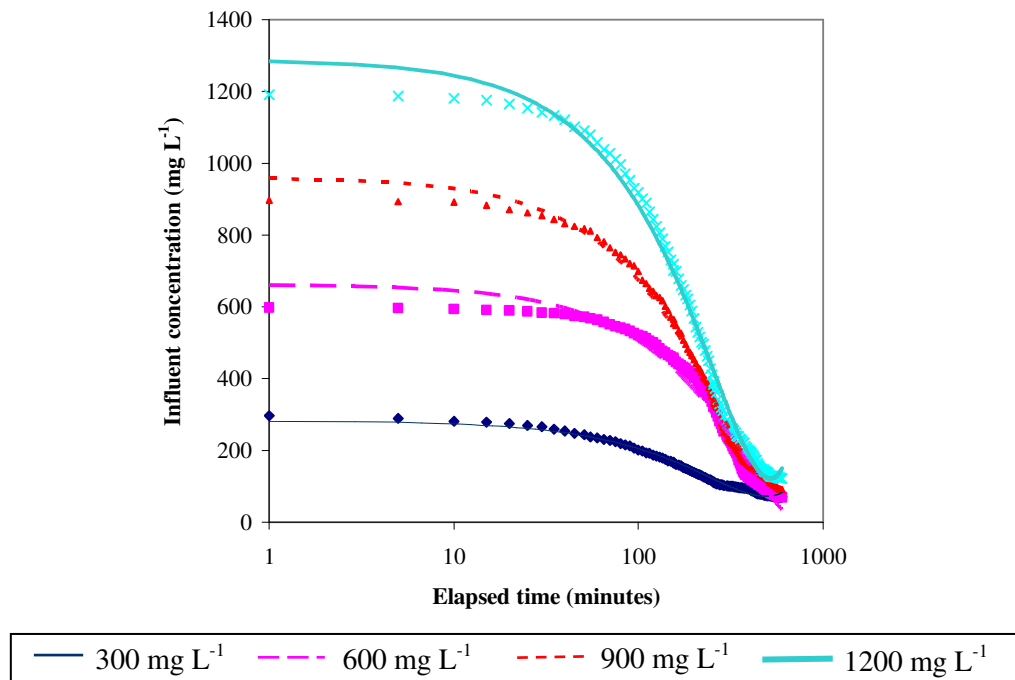

FIGURE 6. Variation of influent concentration with elapsed time for four concentrations of solid suspension.

The empirical relationships were formulated (equations 10; 11; 12 and 13) between the influent concentration and elapsed time as given below.

$$C_i = 0.0009 t^2 - 0.8569 t + 282.11 \quad R^2 = 0.9884 \text{ for } 300 \text{ mg L}^{-1} \text{ solid suspension} \quad (10)$$

$$C_i = 0.001 t^2 - 1.6748 t + 662.22 \quad R^2 = 0.9807 \text{ for } 600 \text{ mg L}^{-1} \text{ solid suspension} \quad (11)$$

$$C_i = 0.0029 t^2 - 3.1564 t + 960.53 \quad R^2 = 0.9951 \text{ for } 900 \text{ mg L}^{-1} \text{ solid suspension} \quad (12)$$

$$C_i = 0.0043 t^2 - 4.4995 t + 1288.4 \quad R^2 = 0.9943 \text{ for } 1,200 \text{ mg L}^{-1} \text{ solid suspension} \quad (13)$$

where,

C - influent concentration,  $\text{mg L}^{-1}$ , and  
 t - elapsed time, minutes

The variation of the filtration efficiency for different concentrations with elapsed time is presented in the Figure 7.

It may be seen that the filtration efficiency decreases with elapsed time. In the initial stages, the concentration is more and the pressure drop is more, therefore the separation efficiency is increased for some elapsed time. But later, the influent concentration decreases and the separation of finer particles will be difficult, so the separation efficiency decreases. The maximum efficiency of different solid suspension of 300; 600; 900 and 1,200  $\text{mg L}^{-1}$  are 30.3; 32.96; 43.89 and 52.5% and the minimum efficiencies are 9.91; 9.93; 9.62 and 9.9%, respectively. The final efficiency for all the concentrations are the same irrespective the change in concentration (equations 14; 15; 16 and 17).

$$\eta = -5 \times 10^{-5} t^2 + 0.0001 t + 27.27 \quad R^2 = 0.9539 \text{ for } 300 \text{ mg L}^{-1} \text{ solid suspension} \quad (14)$$

$$\eta = -4 \times 10^{-5} t^2 - 0.0162 t + 33.295 \quad R^2 = 0.9825 \text{ for } 600 \text{ mg L}^{-1} \text{ solid suspension} \quad (15)$$

$$\eta = -2 \times 10^{-5} t^2 - 0.0525 t + 45.842 \quad R^2 = 0.9849 \text{ for } 900 \text{ mg L}^{-1} \text{ solid suspension} \quad (16)$$

$$\eta = 0.0001 t^2 - 0.1538 t + 59.321 \quad R^2 = 0.972 \text{ for } 1,200 \text{ mg L}^{-1} \text{ solid suspension} \quad (17)$$

where,

$\eta$  - filtration efficiency, %, and  
 t - elapsed time, minutes.



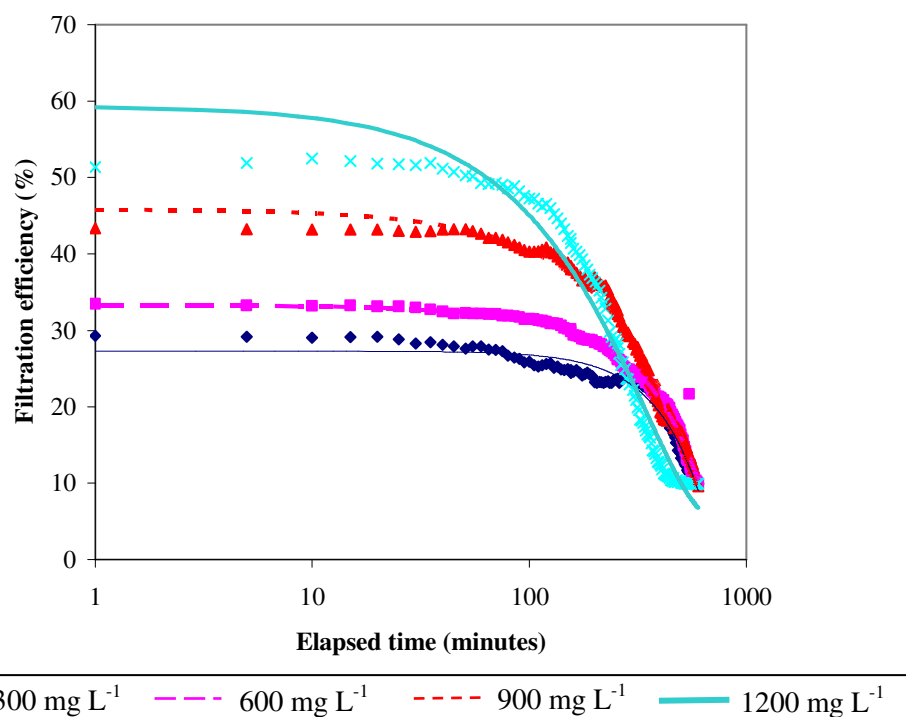

FIGURE 7. Variation of filtration efficiency with elapsed time for four concentrations of solid suspension.

## CONCLUSIONS

The clean water pressure drop, which varied 1.44 to the power of inflow rate, can be used as minimum pressure loss index of its respective inflow rate. The time varying discharge and head loss across the filter inversely related during long run. The variation of the influent concentration is decreased in an increasing rate for some time and then it remains constant. The hydrocyclone tested presented inefficiency to filter small particles such as clay. The initial removal efficiency of higher concentration was more than the lower concentration, but final removal efficiency was not affected very much by the concentration of solid suspension.

## REFERENCES

- ADIN, A.; SACKS, M. Dripper-clogging factors in wastewater irrigation. *Journal of Irrigation and Drainage Engineering*, New York, v.117, n.6, p.813-26, 1991.
- AVEROUS, J.; FUENTES, R. Advances in the numerical simulation of hydrocyclone classification. *Canadian Metallurgical Quarterly*, New York, v.36, n.5, p.309-14, 1997.
- BUREAU OF INDIAN STANDARDS. *Indian Standard: Irrigation equipment-Hydrocyclone filters-specification*. IS: 14743-1999, New Delhi, 1999. 259 p.
- CHAUHAN, H.S. Product standardization in microirrigation. In: WORKSHOP ON MICROIRRIGATION & SPRINKLER IRRIGATION SYSTEMS, 1., 1998, New Delhi. *Proceedings...*New Delhi: Central Board of Irrigation and Power, 1998. p.VI-3-VI-6.
- CHEN, W.; ZYDEK, N.; PARMA, F. Evaluation of hydrocyclone models for practical applications. *Chemical Engineering Journal*, Amsterdam, v.80, n.1-3, p.295-303, 2000.
- KILMA, M.S.; KIM, B.H. The separation of fine, high-density particles from a low-density solid matrix using a hydrocyclone filter. *Journal of Environmental Science and Health*, New York, v.31, n.2, p.305-23, 1996.
- NAKAYAMA, F.S.; BUCKS, D.A. Water quality in drip/trickle irrigation - a review. *Irrigation Science*, New York, v.12, n.4, p.187-92, 1991.

PATIL, D.D.; RAO, T.C. Classification evaluation of water injected hydrocyclone. *Mineral Engineering*, Oxford, v.12, n.12, p.1527-32, 1999.

PUPRASERT, C.; HEBRARD, G.; LOPEZ, L.; AURELLE, Y. Potential of using hydrocyclone and hydrocyclone equipped with grit pot as a pre-treatment in runoff water treatment. *Chemical Engineering and Processing*, New York, v.43, n.1, p.67-83, 2004.

ROVINSKY, L.A. Application of separation theory to hydrocyclone design. *Journal of Food Engineering*, New York, v.26, n.2, p.131-146, 1995.

SCHWANKL, L.; HANSON, B.; PRICHARD, T. Filtration equipment for drip irrigation. *Irrigation Journal*, California, v.46, n.3, p.8-9, 1996.

SOCOL, O.J.; BOTREL, T.A.; GERVÁSIO, E.S.; ULMANN, M.N. Avaliação de um hidrociclone de Rietema para remoção de areia de água de irrigação. *Revista Brasileira de Engenharia Agrícola e Ambiental*, Campina Grande, v.9, n.4, p.464-8, 2005.

SRIVASTAVA, S.K.; SINGH, K.K.; SINGH, P.K.; SINGH, R.P. Hydraulic performance study of drip irrigation hydrocyclone filter. In: WORKSHOP ON MICROIRRIGATION & SPRINKLER IRRIGATION SYSTEMS, 1., 1998, New Delhi. *Proceedings...* New Delhi: Central Board of Irrigation and Power, 1998. p.III-33-III-38.

VALLEBUONA G.; CASALI, A.; FERRARA, G.; LEAL, O.; BEVILACQUA, P. Modeling for small diameter hydrocyclones. *Mineral Engineering*, Oxford, v.8, n.3, p.321-7, 1995.