

Fred L. Amorim

fred.amorim@puocpr.br
Pontifical Catholic University of Parana – PUCPR
Department of Mechanical Engineering
80215-901 Curitiba, PR, Brazil

Walter L. Weingaertner

Emeritus Member, ABCM
wlw@imp.ufsc.br
Federal University of Santa Catarina- UFSC
Department of Mechanical Engineering
80040-970 Florianópolis, SC, Brazil

The Behavior of Graphite and Copper Electrodes on the Finish Die-Sinking Electrical Discharge Machining (EDM) of AISI P20 Tool Steel

The machining parameter settings installed at CNC EDM machines are developed under optimum process conditions. Standard workpiece and electrode materials are used traditionally by machine manufacturers to establish the EDM parameter settings. However, this is not the usual situation of the tooling industry, where many different grades of workpiece and tool electrode materials are used. Consequently, the customers are required to develop their own process parameters, which normally demand many experimental tests. According to the aforementioned argument an experimental investigation on the EDM of AISI P20 tool steel under finish machining has been carried out. The tests were performed with graphite and copper as tool electrodes. Important EDM electrical parameters that influence the process performance were investigated. The measured technological outputs were the material removal rate V_w , volumetric relative wear ϑ and workpiece surface finish R_a . The main conclusions can be summarized as follows: the best results for material removal rate V_w were reached when EDM with negative graphite electrodes. Graphite and copper tools presented similar results of V_w for positive polarity. For graphite and copper tools the lowest values of volumetric relative wear were achieved for positive polarity. The best surface roughness R_a was obtained for copper electrodes under negative polarity.

Keywords: sinking EDM, graphite and copper electrodes, tool steel, process parameters

Introduction

EDM has advanced to one of the major manufacturing processes applied in die and mold making industry to generate three-dimensional complex cavities in many different classes of materials in rough and finish operations, as reported by König (1991). Examples include precision machining of materials such as hardened steels, carbides, ceramics and any other material that offers 0,01 S/cm of electrical conductivity, as depicted in Fig 1. Recently, other researchers (Amorim & Weingaertner, 2002, 2004) also reported that special aluminum-based alloys and copper-beryllium alloys, which are used to produce special injection molding tools, have also been machined by EDM. In addition, Masuzawa (2001) remarks that EDM is gaining more and more importance on the production of very accurate small parts (dimensions < 0,5 mm) on any electrical conductive material. This is a market trend known as Micro-EDM.

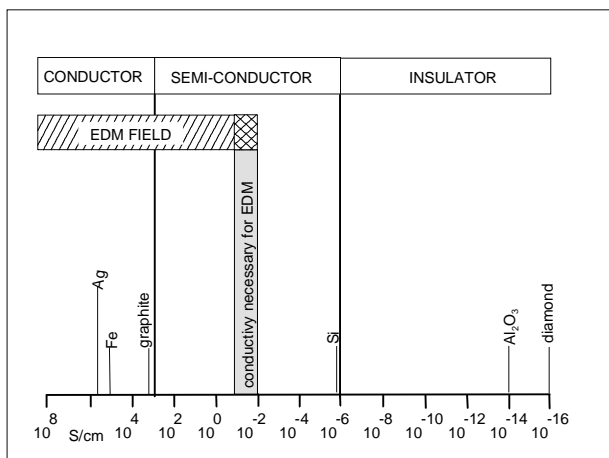

Figure 1. Electric conductivity necessary for EDM, König (1991).

According to König *et al.* (1975) since the early stages of the process of electrical discharge machining (EDM) by Lazarenko (1944) various causes for the material removal have been postulated. Kahng & Rajurkar (1977) have reported the electro-mechanical and thermo-mechanical theories. The first theory suggests that a very high electric field is attributed to separate material particles of the workpiece as it exceeds the forces of cohesion in the lattice of the material. However, experimental evidence lacks supports to this theory. The second theory (thermo-mechanical) proposes that a variety of electrical effects of the discharge is responsible to the melting of material of the workpiece. Nevertheless, this theory does not agree with experimental results and then do not give a reasonable explanation for EDM phenomenon.

Nowadays, there is no complete and definite model explaining in all details the different processes that take place during a discharge. As presented by several researches² the best supported theory still accepted to explain the electrical discharge machining of metals is based on the thermoelectric phenomenon. According to that theory the material removal in EDM is associated with the erosive effect produced when spatially and discrete discharges occur between two electrical conductive materials. Sparks of short duration (0,1 to 3600 μ s) are generated in a liquid dielectric gap separating tool and workpiece electrodes.

Figure 2 presents the phases of an EDM discharge. The four phases of a single discharge in EDM can be shortly presented as follows. The first one is the ignition phase. It represents the delay time (t_d) to the occurrence of the breakdown of the high open circuit voltage (\hat{u}_i), applied across the working gap, until the fairly low discharge voltage (u_c). The second phase instantaneously occurs right after the first one, when the current rapidly increases to the operator specified peak current (i_c). It is the formation of a plasma channel surrounded by a vapor bubble. The third phase is the discharge phase. Here the high energy and pressure plasma channel

² König & Klocke (1997), Eubank *et al.* (1993), Dibitonto *et al.* (1989), Mukund (1989), Van Dijk *et al.* (1974), Schumacher (1966), Müller (1965), Zolotck (1955).

is sustained for a period of time (t_e) causing melting and evaporation of a small amount of material in both electrodes. The fourth phase is the collapse of the plasma channel when the electric energy is turned off. This phase causes the molten material to be violently ejected. At this time, known as interval time (t_0), a part of the molten and vaporized material is flushed away by the flow of the dielectric across the working gap and the rest is solidified in the recently formed crater and surroundings. This process continues until the geometry of the workpiece is completely machined.

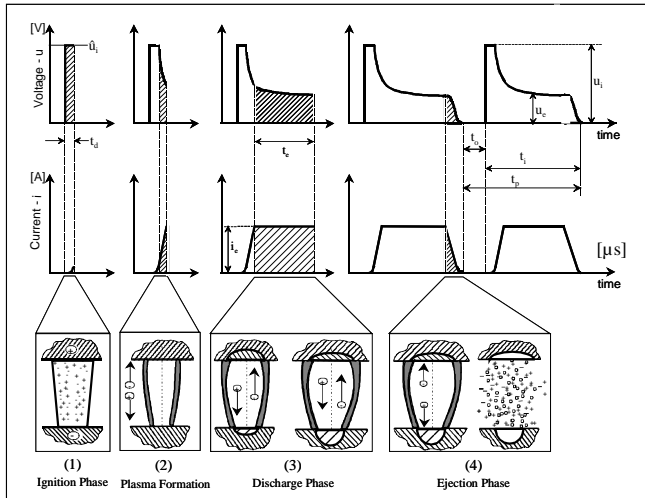

Figure 2. The phases of an electrical discharge in EDM (König & Klocke, 1997).

According to the aforementioned EDM theory the mechanical properties of the workpiece and the tool electrode have negligible effect on machining performance. However, the thermophysical properties of the workpiece and tool electrode (thermal and electrical conductivity, thermal expansion, heat to vaporize from room temperature, melting and boiling temperature) have considerable influence on the EDM process performance in terms of material removal rate, electrode wear and surface integrity of the workpiece.

Drozda (1998) reminds that the tool electrode is responsible to transport the electrical current to the workpiece. Therefore, any material to be used as a tool electrode is required to conduct electricity. In fact, there is a wide range of materials used to manufacture electrodes, for instance, brass, tungsten carbides, electrolytic copper, copper-tungsten alloys, silver-tungsten alloy, tellurium-copper alloys, copper-graphite alloys, graphite etc. In respect to the application of electrolytic copper and graphite as tool electrodes, the following arguments can be summarized:

(i) **COPPER**: it works very well as an electrode material and is widely used when smooth workpiece surface finishes are required. This material can be machined by all conventional methods such as drilling, turning, milling, grinding etc. But machining can be sometimes difficult because copper has a trend to drag on the edge of the cutting tool and the grinding wheel. In this case 2% Tellurium-copper alloy, which presents better machinability, can be a choice. However, copper machines on Wire EDM better than graphite. Very complex shapes can be obtained by Wire EDM onto copper electrodes. Another advantage of copper in comparison to graphite is its ability to be coined and then to be a very good material for engraving electrodes. For certain applications, such as electrodes to be used in medicine engineering field, copper is the best choice because of its facility to be highly polished.

(ii) **GRAPHITE**: this material is available in many different grades from large grain sizes (200 μm), used in rough EDM

operations, to very fine grains (1 μm) for finish EDM operations, particularly in steel. The costs of graphite vary from inexpensive, for coarse-grain sizes, to very expensive for fine-grain sizes. It provides a high material removal rate and low electrode wear - depending on the EDM parameter settings - as compared to metallic electrodes. At the present there is a trend to incorporate the entire geometrical configuration of the workpiece onto a single large electrode, instead of partitioning the tool in many small pieces. Thus, the weight of the electrode becomes very important because it affects many factors in handling construction and use of the electrode. Graphite has a much lower density than copper, which makes it the best material for large electrodes. Although graphite is very abrasive it is relatively easy to be machined by all the conventional machining processes. Milling, drilling, turning, grinding and ultrasonic machining provide excellent finishes in graphite. The major drawback of graphite is the fine dust it produces during its machining. It is able to settle on the guides of the machine tool and when mixed with the machine's cutting fluid it will act like a lapping compound, which eventually reduces the accuracy of the machine. Precautions must be taken when machining graphite.

Vartanian & Rosenholm (1992) pointed out that for many years there have been discussions about the relative merits of the different EDM electrode materials. The major debates are about copper versus graphite. The EDM users in different parts of the world have been using different electrode materials to do exactly the same jobs. Normally, copper is mainly used in Europe or Asia for historical reasons. Graphite is the chosen material by the majority of EDM users from the United States of America. Most EDM jobs that can be done with copper can also be executed with graphite. The end result might be the same, but the cost to accomplish the job can be vastly different. In practical terms the choice of the electrode material will depend mainly on the tool size, the workpiece requirements, type of EDM machine and the methods of making the electrodes. Other important factors shall be considered when selecting the electrode material:

(a) *Workpiece material removal rate V_w [mm^3/min]*: a correct choice of EDM parameters to the pair tool /workpiece electrode materials will increase the value of V_w .

(b) *Electrode resistance to wear*: there are four types of wear: volumetric, corner, end and side wear. Of the four, volumetric and corner wear are very important in finish EDM operations of fine details. Minimization of those wear requires choosing adequate EDM parameters and proper electrode material.

(c) *Workpiece surface roughness*: good workpiece quality is obtained by the proper choice of electrode material, good flushing conditions and adequate EDM parameter settings.

(d) *Tool electrode material machinability*: copper and graphite are the most commonly used. However, it is important to select an electrode material where the macro and microgeometry of the workpiece can be easily machined. It promotes reduction of machining time and costs.

(e) *Tool electrode material cost*: on average, fine graphite is about three times more expensive than copper. The choice shall be done considering the company facilities (e.g. machine-tools, CAD/CAM software technology etc). It also includes the know-how on machining copper and graphite electrodes, the complexity of the electrode and its difficulty to be redressed and the knowledge on EDM parameters.

The present work was focused in two major objectives. It is known that graphite is a relatively new tool electrode material to the Brazilian EDM users. Then the first objective was to provide technological information on the use of graphite when EDM steel workpieces in finish process conditions. The second objective was to attain more understanding about the EDM phenomena when machining with graphite electrodes in comparison to copper. It is

because technological and basic research debates are still currently being carried out worldwide.

This research work is focused in assessing the finish EDM behavior of AISI P20 tool steel using a special grade of graphite and copper as electrodes. Important EDM electrical parameters that influence the process performance were investigated in terms of the following technological results:

(a) Material removal rate V_w : which represents the volume of material removed from the workpiece per unit time [mm^3/min];

(b) Volumetric relative wear ϑ : which represents the ratio of electrode wear rate V_e to material removal rate V_w , expressed in percentage values.

(c) Surface finish of the machined workpieces R_a [μm].

Nomenclature

\hat{i}_e	= discharge current, A
t_p	= pulse cycle time, μs
p_{in}	= dielectric inlet pressure, MPa
u_e	= discharge voltage, V
t_d	= ignition delay time, μs
\hat{u}_i	= open circuit voltage, V
t_e	= discharge duration, μs
V_e	= electrode wear rate, mm^3/min
t_i	= pulse duration, μs
V_w	= material removal rate, mm^3/min
t_0	= pulse interval time, μs

Greek Symbols

ϑ	= volumetric relative wear (V_e/V_w), %
τ	= duty factor, dimensionless

Experimental Procedure

The Electrical Discharge Machining experiments were conducted at the Laboratory for Research on Machining Processes (LAUS) of the Pontifícia Universidade Católica do Paraná (Pontifical Catholic University of Paraná) (PUCPR), Curitiba-Brazil. The following materials, equipment and methods were applied for all the series of tests:

(i) *EDM machine*: a Charmilles ROBOFORM 30 CNC machine equipped with an isoenergetic generator, which means that it is possible to set - among others EDM parameters - the discharge duration t_e and to control the ignition delay time t_d as a percentage of t_e . In this work t_d was kept as 30% of t_e for all the experiments because a finish machining would be carried out. It means that low energy would be applied and then longer would be the ignition delay time.

(ii) *Tool electrodes*: 100 mm long cylindrical bars of graphite and copper with diameter of 20 mm and a 4 mm central hole. The main specifications of the graphite used for the tests are 10 μm average grain size, 1,5 μm average pore size, 1,77 g/cm^3 density and 80 W/mK thermal conductivity. The tool electrodes were mounted axially in line with the workpiece samples as shown in Fig 3.

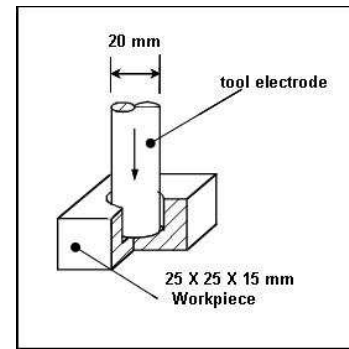

Figure 3. Geometry of the tool and workpiece samples.

(iii) *Workpiece*: AISI P20 tool steel square samples 25 mm wide and 15 mm thick with a roughness R_a of 2 μm on the surface to be machined were prepared by Wire EDM, as shown in Fig.3. The workpiece material was chosen because it is widely used by the die and mold making industry. The surface finish was analyzed using a Surtronic 3 Taylor Hobson roughness measurement equipment. The measurements were done on the bottom of the EDM cavity using a stylus tip of 5 μm , cut-off length of 0,8 mm and evaluation length of 4 mm.

(iv) *Dielectric*: hydrocarbon fluid for universal application in EDM operations with properties of viscosity 3 CSt at 20 $^{\circ}\text{C}$, flash point of 125 $^{\circ}\text{C}$, density of 0,783 g/ml and 0,3 % of aromates.

(v) *Flushing method*: the dielectric fluid was injected through the 4 mm electrode hole with 0,01 MPa providing adequate flushing of the eroded particles away from the working gap. In order to further improve the flushing efficiency an alternation between periods of machining U [s] and periods of tool electrode retraction with no discharges R [s] were introduced, as shown in Fig. 4. The values of U and R were defined after pilot tests.

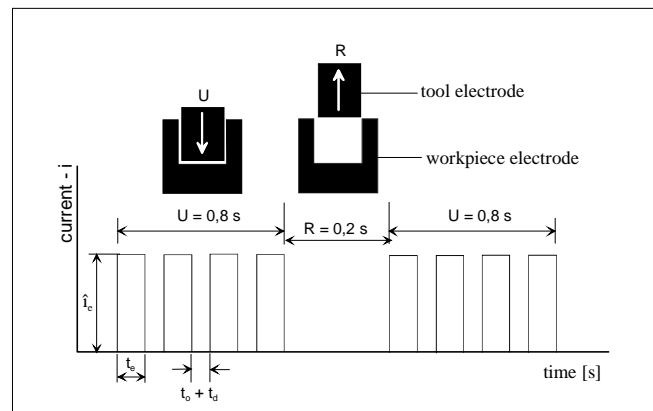

Figure 4. Series of pulses U followed by a pause R [s].

Table 1. Electrical variables used for the experiments with graphite and copper electrodes.

Discharge current	Discharge duration	Pulse interval time	Open Voltage	Tool electrode polarity	Generator mode
\hat{i}_e [A]	t_e [μs]	t_0 [μs]	\hat{u}_i [V]		
3; 6; 8	6,4; 12,8; 25; 50; 100	6,4; 12,8; 25; 50; 100	160	(+) and (-)	isoenergetic

(vi) *Electrical Variables*: the major variables that influence on the performance of EDM, which are discharge current i_e , discharge duration t_e and tool polarity (+/-), were investigated through the values presented in Tab.1

In finishing EDM operations an important objective is to achieve the best workpiece roughness with a low level of volumetric relative wear. So that it could be possible, the duty factor τ (t_i/t_p), which represents the ratio between pulse duration t_i and pulse cycle time t_p ($t_p = t_i + t_0$), was chosen to be 0,5 for all the tests. This value of τ , i.e., $t_i = t_0$, was used because the good stability normally observed on EDM for this condition. It means few occurrence of short-circuits and arc-discharges. As a consequence, proper flushing of eroded particles away from the working gap is promoted. Smaller values of duty factor ($t_i < t_0$) is commonly established by keeping t_i constant and increasing the value of t_0 . This would lead to very low discharges frequencies. It would result in decreasing the material removal rate. On the other hand, levels of τ higher than 0,5 ($t_i > t_0$), set by reducing the value of t_0 in relation to t_i , would probably cause an over-concentration of debris in the working gap. This would lead to non-uniform material removal along the frontal surfaces of the tool and the workpiece, as well as possible increase of the roughness.

The open gap voltage \hat{u}_i has intrinsic relation with the size of the working gap, i.e., the distance between the electrodes during the spark. The higher is the value of \hat{u}_i the larger the working gap. It is common to set \hat{u}_i at lower levels – 80, 100, 120 V - when EDM under rough conditions. It is because the high average energy $W_e = u_e \cdot i_e \cdot t_e$ [J] keeps a larger working gap and proper expulsion of debris. As the energy W_e is decreased so is the working gap size. Thus, in finish EDM is recommended to establish higher values of \hat{u}_i in order to promote more adequate working gap. In this work, the value of $\hat{u}_i = 160$ V was established. This magnitude of \hat{u}_i guaranteed proper dispersion of the sparks along the frontal area of the electrodes and good flushing conditions.

(vii) The precise quantification of material removal V_w and volumetric relative wear ϑ was possible using a precise balance (resolution of 0,0001 g) to weigh the tool and workpiece before and after an average machining time of 30 minutes. The tests were done three times for each parameter settings, and no significant differences were observed among them. It is important to mention that during EDM process the graphite electrodes absorb some quantity of the dielectric fluid. To avoid any error when measuring the mass of the graphite tool it was necessary to carry out a drying period. The electrodes were kept in a furnace at 400 °C for 24 hours before and after each EDM test.

Results and Discussions

Figure 5A shows the results of material removal rate V_w for positive graphite and copper tools versus the variation of discharge duration t_e and discharge current i_e . For both tool materials the optimum discharge duration t_e was 50 μ s at $i_e = 3, 6$ and 8 A, where the best results of V_w and good stability of the EDM were observed. For $i_e = 6$ and 8 A the values of V_w are similar for both materials, reaching a maximum of 8 mm³/min. When EDM with graphite tool at $i_e = 3$ A the value of V_w was about 1,5 mm³/min higher than the values of copper. This difference is not significant for EDM with finish parameter settings. The general performance of EDM is similar for the two electrode materials. Some tests with longer discharge duration ($t_e = 100 \mu$ s) were carried out, but the values of V_w had a trend to deeply decrease for the two electrode materials.

Figure 5B depicts the results of volumetric relative wear ϑ (V_e/V_w) for positive graphite and copper versus the variation of discharge duration t_e and discharge current i_e (3, 6, 8 A). When EDM machining at the optimum conditions ($t_e = t_0 = 50 \mu$ s) graphite

presented an average value of volumetric relative wear ϑ of about 4 to 6% while copper has achieved 2%. Moreover, it is observed that the volumetric wear ϑ is much higher for graphite than for copper from $t_e = 6,4$ to 25 μ s, which represent very short levels of t_e and interval time t_0 . It probably occurred because the short interval times t_0 were not sufficient to efficiently flush the electrode and workpiece debris away from the working gap. When EDM in finish conditions the working gap is very small, i.e. it varies from 10 to 50 μ m width (Drozda,1998). The grain size of graphite is essential to guarantee a stable EDM process. In this work a 10 μ m graphite grain size was used to carry out the experiments.

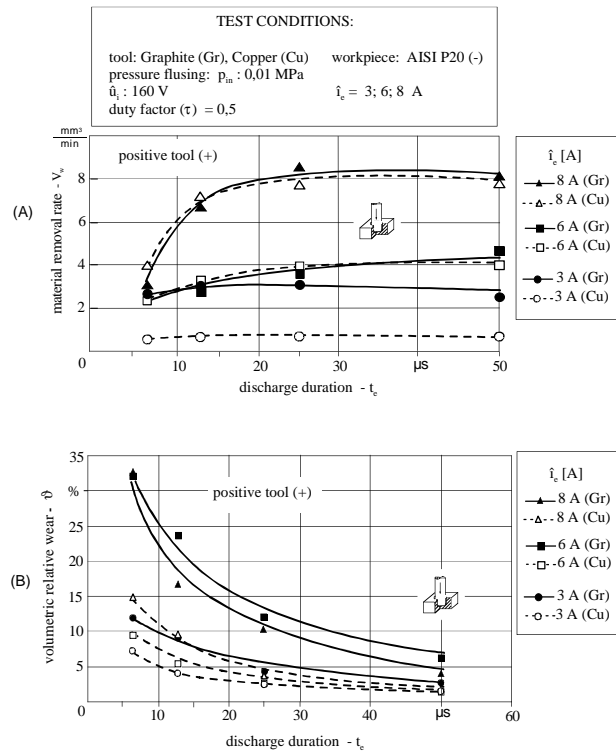

Figure 5. (A) Material removal rate V_w and (B) volumetric relative wear ϑ against the variation of discharge current i_e and discharge duration t_e for EDM with positive graphite and copper electrodes.

Therefore, it is possible that particles separated of the tool electrode tended to clog the working gap, causing short-circuits and arc-discharges. Thereafter this phenomenon has brought V_w to lower levels and electrode wear rate V_e to higher levels. As a consequence the volumetric relative wear ϑ (V_e/V_w) was increased when EDM was performed with $t_e = t_0$ from 6,4 to 25 μ s, as can be noticed at Fig. 5B. Here it is possible to say that the 10 μ m graphite grain size would probably give better results if applied to EDM with higher rates of i_e, t_e, t_0 , when the working gap width would be larger and the EDM performance could be more stable. It means that higher V_w and lower ϑ would be reached.

Figure 6A presents the results of material removal rate V_w when EDM with negative polarity graphite tool (cathode). Despite the values of discharge current i_e and discharge duration t_e it is observed that negative polarity for graphite promoted very much higher values of material removal rate V_w than the ones achieved with graphite at positive polarity (anode), as depicted before in Fig. 5A.

When EDM under the optimum discharge duration $t_e = 50 \mu$ s and $i_e = 8$ A the maximum material removal rate $V_w = 23,5$ mm³/min was obtained for negative polarity, while for positive graphite the maximum $V_w = 8$ mm³/min was reached (Fig. 5A). This EDM performance can also be noticed for discharge current i_e at 3

and 6 A, where the maximum V_w about $10 \text{ mm}^3/\text{min}$ was reached for $t_e = 50 \mu\text{s}$.

When comparing Fig. 6A against 6B, where V_w for negative copper tools (cathode) are presented, the results of material removal V_w for graphite *versus* copper are vastly different. In the case of copper the maximum V_w was about $0,12 \text{ mm}^3/\text{min}$ when EDM with $\hat{i}_e = 8 \text{ A}$ at the optimum $t_e = 12,8 \mu\text{s}$, which is much lower than those of graphite tools in any circumstances.

The performance of any electrical discharge machining operation greatly depends on the thermophysical properties of the electrode material, although the non-thermal properties (electrodynamical and mechanical effects) are not negligible. The discharge current \hat{i}_e just takes place after the break down of the open circuit voltage \hat{u}_i . The occurrence of this phenomenon is just possible when the cathode electrode starts to emit electrons. At this time, the electrons from the cathode collide with molecules of the dielectric fluid and more electrons are released together with positive ions. As a result, the dielectric fluid is vaporized and a high energy plasma channel is formed (Stevens, 1998). In addition, Drozda (1998) arguments that the cathode must be hot enough to permit electrons to absorb enough energy to escape. The thermophysical properties of copper are very different from graphite. When the cathode is copper it is able to emit electrons, to carry the current, only after some of its own material is melted and boiled. On the other hand, when graphite is the cathode it is able to emit electrons below its sublimation temperature. Therefore graphite is more stable than copper as cathodes, which promotes higher material removal rates V_w , see Fig 6.

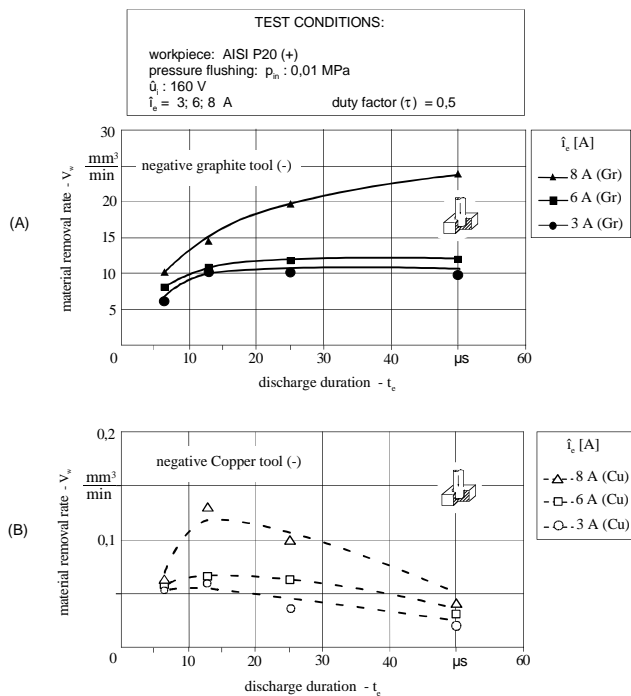

Figure 6. Material removal rate V_w against discharge current \hat{i}_e and discharge duration t_e for (A) EDM with negative graphite tool and (B) for EDM with negative copper tool.

The results of workpiece surface roughness for copper and graphite tools at negative and positive polarity can be seen respectively in Fig. 7A and 7B. It is observed that negative graphite tool electrodes promoted higher roughness than copper tools for all the three discharge currents ($\hat{i}_e = 3, 6, 8 \text{ A}$) and discharge duration t_e evaluated. For EDMachining using graphite at the optimum $t_e = 50 \mu\text{s}$ the R_a varied from 4 to $5 \mu\text{m}$, while copper tools provided much better workpiece surface quality. The best value $R_a = 0,6 \mu\text{m}$ was

attained for $\hat{i}_e = 3 \text{ A}$ and $t_e = 12,8 \mu\text{s}$ using copper electrodes. The higher surface roughness obtained with graphite is due to the higher V_w reached for that material, which means that larger and deeper craters were made in the workpiece surfaces.

Figure 7B depicts the results of EDM with positive polarity for both electrode materials. It is observed just a few divergences on the results. When EDM with $\hat{i}_e = 6, 8 \text{ A}$ and the optimum discharge duration $t_e = 50 \mu\text{s}$ the difference of R_a was about $1 \mu\text{m}$ and for $\hat{i}_e = 3 \text{ A}$ a smaller difference occurred.

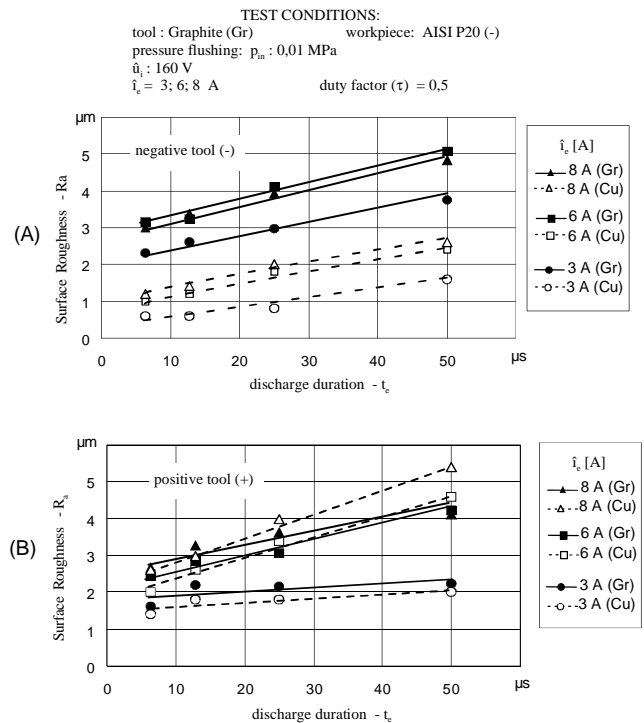

Figure 7. Results of surface roughness when (A) EDM with negative and (B) with positive graphite and copper tool electrodes.

In Figure 8 the results of volumetric relative wear ϑ for EDM with negative electrodes are presented. The negative graphite tools promoted much higher volumetric wear $\vartheta = 30\%$ ($\hat{i}_e = 8 \text{ A}$, $t_e = 50 \mu\text{s}$) than with EDM at positive polarity ($\vartheta = 6\%$, $\hat{i}_e = 8 \text{ A}$, $t_e = 50 \mu\text{s}$ which represent the best parameter settings) as shown before in Fig. 5B.

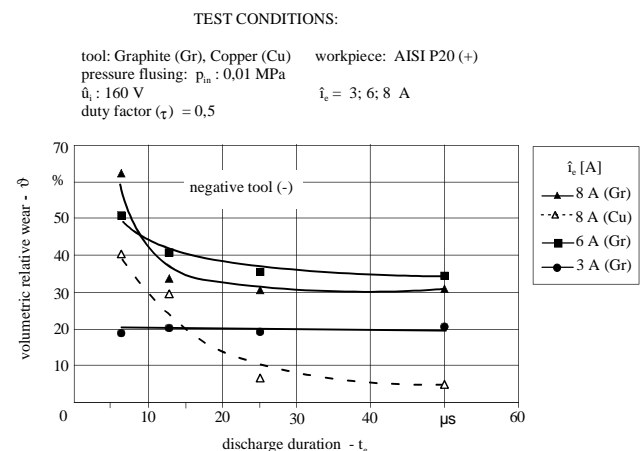

Figure 8. Volumetric relative wear ϑ for the variation of discharge current and discharge duration when EDM with negative graphite ($\hat{i}_e = 3,6,8 \text{ A}$) and copper ($\hat{i}_e = 8 \text{ A}$).

The same behavior is also noticed for negative copper tools at their best EDM settings, i.e. for $\hat{i}_c = 8A$ $t_c = 12,8 \mu s$ the volumetric relative wear ϑ is also about 30%. Although not represented in Fig. 8, when EDM with copper at $\hat{i}_c = 3$ and 6 A for the optimum $t_c = 12,8 \mu s$ the volumetric relative wear of 40% was observed.

Conclusions

This work has carried out experiments on the performance of a special grade of graphite when electrical discharge machining AISI P20 tool steel under finish conditions. It has been investigated important EDM variables such as discharge current, discharge duration and tool electrode polarity. From the results of this work the following conclusions can be drawn:

(a) The highest material removal rates V_w were achieved for EDM with negative graphite electrodes, much better than the results reached with copper tools. Therefore graphite is more stable than copper when EDM as cathodes.

(b) For electrodes at positive polarity, graphite and copper presented similar results in terms of the values of V_w . Probably the 10 μm grain size of the graphite used for the experiments should be applied with higher discharge currents, when the working gap width would be larger and the EDM performance could be more stable. It means that higher V_w and lower electrode wear ϑ would be reached.

(c) The lower levels of volumetric relative wear ϑ were attained for EDM with graphite and copper at positive polarity despite the EDM parameter settings.

(d) The best surface roughness R_a was obtained for copper electrodes under negative polarity.

References

Amorim, F. L. and Weingaertner, W. L., 2004, "Die-sinking electrical discharge machining of a high-strength copper-based alloy for injection molds", *Journal of the Brazilian Society of Mechanical Sciences*, Vol. 26, No. 2, pp. 137-144.

Amorim, F. L. and Weingaertner, W. L., 2002, "Influence of duty factor on the die-sinking electrical discharge machining of high-strength aluminum alloy under rough machining", *Journal of the Brazilian Society of Mechanical Sciences*, Vol. 24, No. 3, pp. 194-199.

Crookall, J. R. and Khor, B. C., 1974 "Electro-discharge surfaces", 15th International Machine Tool Design and Research Conference, Birmingham, UK, [S.N], Vol.1, pp 373-384.

Dibitonto, D. D., et al., 1989, "Theoretical models of the electrical discharge machining process I: a simple cathode erosion mode", *Journal of Applied Physics*, Vol. 66, No. 9, pp. 4095-4103.

Drozda, T. J., 1998, "Tool and Manufacturing Engineers Handbook: Machining", USA: Society of Mechanical Engineers, Vol.5.

Eubank, P. T., et al., 1993, "Theoretical models of the electrical discharge machining process III: the variable mass, cylindrical plasma mode", *Journal of Applied Physics*, Vol. 73, No. 11, pp. 7900-7909.

König, W., 1991, "Advanced ceramics: sparks machine ceramics". *PMI*, Vol. 23, No. 2, pp.96-100.

König, W. and Klocke, F., 1997, "Fertigungsverfahren - 3: Abtragen Und Generieren", Berlin: Springer, Vol.3.

König, W., Wertheim, R., Zvirin, Y. and Roren, M., 1975, "Material removal and energy distribution in electrical discharge machining", *Annals of the CIRP*, Vol. 24, No. 1, pp. 95-100.

Lazarenko, B.R., 1944, "Die Elektrodenfunkenbearbeitung von Metallen", *Vestnik Mashinostroia*, Moscow, Vol. 1, No. 1, pp. 25-36.

Masuzawa, T., 2001, "Keynote paper: micro-EDM", ISEM 13th International Symposium for Electromachining, Bilbao, Spain, Vol. 1, pp.3-19.

Mironoff, N., 1970, "Introduction into the Study of Spark Erosion", 2nd ed., Mirotecnic-Scriptor.

Mukund, R.; Barrufet, M.A. and Eubank, P. T., 1989, "Theoretical models of the electrical discharge machining process II: the anode erosion model", *Journal of Applied Physics*, Vol. 66, No. 9, pp. 4104-4111.

Müller, H., 1965, "Beitrag zur klärung funkenerosivvorgänge", *Elektrowärme*, Germany, Vol. 23, No. 3.

Schumacher, B.M., 1966, "Das leistungsverhalten und der werkzeugverschleiss bei funkenerosiven bearbeitung von stahl mit speicher und impulsenergiegeneratoren", Doctorate Thesis - WZL- Laboratorium für Werkzeugmaschinen und Betriebslehre der RWTH-Rheinisch-Westfälischen Technischen Hochschule, Aachen, Germany.

Stevens, L., 1998, "Improvement of surface quality in die-sinking EDM". Doctorate thesis - Department of Mechanical Engineering, K.U. Leuven, Belgium.

Van Dijk, F., et. al., 1974, "Some results of physical research in EDM", 4th International Symposium for Electromachining, Bratislava, Poland, Vol. 1, pp.68-85.

Vartanian, M.A. and Rosenholm, O., 1992, "Methods of manufacturing" Manufacturing Conference, Chicago, USA. Vol. 1, pp 1-16.

Zolotyck B.N., 1955, "Physikalische Grundlagen Der Elektrofunkbearbeitung Von Metallen", Veb Verlag Technik, Berlin, Germany.