

## Comparison of experimental and finite element analysis results of a sheet metal prototype vehicle door hinge in X, Y and Z directions

Hande Güler Özgül<sup>1</sup>, Onur Erol<sup>2</sup>

<sup>1</sup>University of Uludag, Department of Automotive Engineering, Campus of Görükle, TR-16059, Nilüfer, Bursa, Turkey

<sup>2</sup>University of Uludag, Department of Automotive Engineering, Campus of Görükle, TR-16059, Nilüfer, Bursa, Turkey

e-mail: handeguler@uludag.edu.tr, onurerol91@gmail.com

---

### ABSTRACT

In this study, the geometric differences which have a significant effect on the simulation results of the sheet metal prototype vehicle door hinge have been revealed. This geometric difference was examined by finite element simulations and experimental tests for the loads in the X, Y and Z directions specified in the UNECE R11 regulation.

As a result, the curves of the finite element simulations and the experimental tests compared for each direction were examined and it was concluded that the compatible model with the experimental tests of the sheet metal prototype vehicle door hinge was 3D scan model.

**Keywords:** Finite element simulation, UNECE R11 regulation, Vehicle door hinge, 3D scan, Cad model.

---

### 1. INTRODUCTION

Finite element method is an effective method used in all parts of engineering as well as in automobile parts. However, finite element analysis is not only sufficient and results of the analysis should be correlated with the experimental studies and confirmed. One of the automobile parts is vehicle door hinge and important for the connection between the door and the vehicle body. This component must ensure passenger safety; therefore, the hinges must undergo various tests according to some specifications.

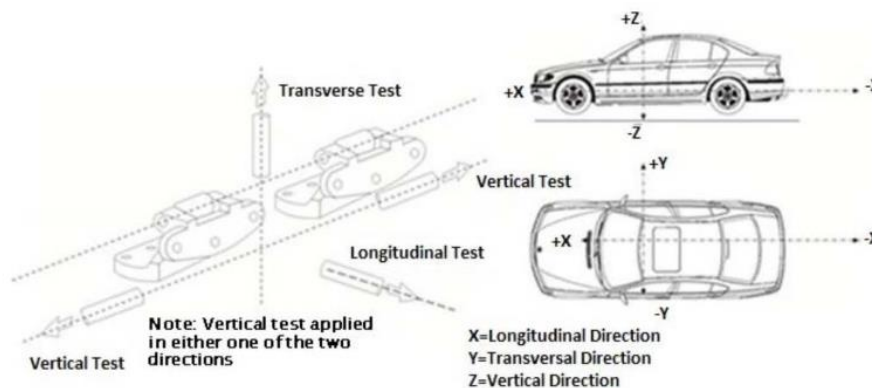
There have been several studies that have researched design, finite element simulation and experimental studies of vehicle hinges. CHIANG *et al.* [1] investigated the influences of 15 design parameters and loading conditions on angular deflections of side door hinges and thirteen factors were statistically significant. BAO *et al.* [2] and ZHANG *et al.* [3] successfully regulated an intelligent system for door hinge layout to arrange and shorten the design periods. HALILOVIC and KOVACEVIC [4] studied to shorten shape optimization processes of an automotive bonnet hinges using simplifications, and simple comparative method. Increasing the press formability of a door hinge was examined by TOA *Net al.* [5] using FE simulations based on the Taguchi's method. LEE *et al.* [6] researched a design method using three-dimensional electric field analysis and a backward tracing scheme to shape rolling of a rear door hinge. TÜFEKÇI *et al.* [7] designed different vehicle door hinges using topology optimization method. A new aluminum design was manufactured and mass reduction about 60% was achieved. MORE *et al.* [8] designed the lateral door hinge according to FMVSS No.206 and Indian standard (IS): 14225, an optimum model was accepted conducting FEA studies and experimental tests. YILMAZ *et al.* [9] produced a lighter prototype by using aluminum instead of steel. Experimental tests and FEA performed for loading of the hinge according to FMVSS No.206 standard and a reduction of approximately 65% in weight of the door hinge was achieved by using Al7075-T73 alloy. DOGAN *et al.* [10] conducted a correlation study on forged commercial door hinge about FMVSS206 and door sagging load cases. In their study, they have compared FEA setup with experimental test and shared their FEA input data. TÜFEKCI *et al.* [11] investigated optimal hinge design against wind gust condition. At the beginning, they have realized only FEA calculations. After, they have evaluated their FEA setup again due to fail experienced at experimental test and shared their correlation. They have suggested their opinion for optimal design as a conclusion of their study. DESAI *et al.* [12] developed FEA model to investigate NVH behavior of side door. They have compared their FEA results with experimental tests to validate their

setup. In study, friction coefficient, boundary conditions and material were shared about hinges. Bekah [13] have investigated fatigue behavior of vehicle door hinge with FEA tool. He has shared boundary condition of door system. PATIL *et al.* [14] investigated sagging performance of dryer hinge in their study with FEA and experimental test. They have validated their FEA setup by comparing FEA results with experimental test results. LU *et al.* [15] suggested applying airbag system to vehicle door to avoid head injury of non-motor driver. They have investigated acceleration and forces experienced on hinges during accident. SHINDE *et al.* [16] studied on sagging performance of commercial vehicle door hinge. They have used Hyperworks simulation tool for investigations and suggested a new optimized model by size optimization. There foreit was indicated at study that total weight for all doors were reduced by %42.RAZAK*et al.* [17] studied on opening strength of door under OEM's load cases. Abaqus simulation software has been used in study. They have checked correlation of results and improved their first model in order to accomplish customer needs. As a results, they have suggested stopper which has 2.5 mm thickness instead of 1.5 mm one. MUNDE *et al.* [18] investigated stress results of door hinge under various loads. At study, simulation loads were chosen by considering servicing loads of commercial vehicle doors. They have shared stress results, stress concentration and deflection results in their study as conclusion. YILDIZ *et al.* [19] studied on optimizing vehicle door hinge by changing its design and material. Various load cases has been simulated and optimization studies carried out by hypermesh simulation software. Also PA6GF60 were indicated as best composite material options among to others and %8.12 material reduction has been made on geometry and presented in study. BHASKAR *et al.* [20] have investigated various materials to find out lightest and stiffest bonnet material. They have used hypermesh and optistruct to reduce material from bonnet geometry. As a conclusion, lightweight model were presented with information of negliable deformation result in their study.

In this study; the geometric differences between design and production for the automobile door hinge are investigated. For this purpose, finite element analysis and experimental tests are performed for X, Y, Z directions specified by UNECE R11(United Nations Economic Commission of Europe)specification according to vehicle axis. The FEA and verification of the experimental test results are carried out and the reasons for the geometric differences between design and production are revealed.

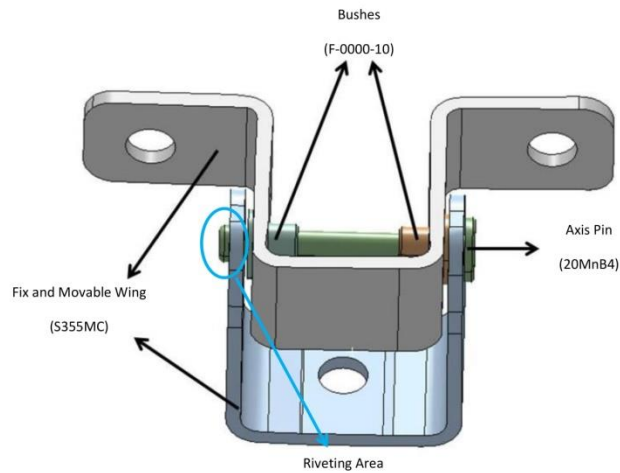
**2. EXPERIMENTAL PROCEDURE**

UNECE R11 specification has been created by United Nations Economic Commission of Europe to reduce passenger incidents like being thrown out of the vehicle during collision. In order to achieve this target, the specification indicated load cases (vertical case is available only if door opens vertically) as 11000 N in longitudinal direction, 9000 N in transversal direction and 9000 N in vertical direction in Figure 1.Retention components of the door must show no separation is indicated as acceptance criteria of specification [21].In this study, experimental studies have been carried out for the load cases specified in the UNECE R11 specification and material characterization.

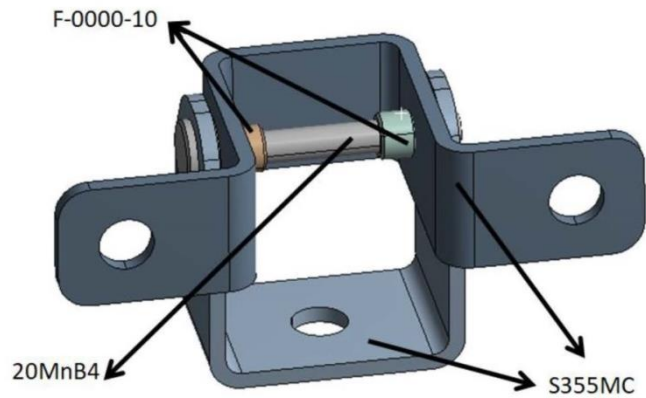


**Figure 1:** Loading directions of United Nations Economic Commission for Europe (UNECE) R11 and loading positions according to vehicle coordinate system

The designed and produced prototype hinge sample in the study consists of movable wing, fixed wing, axis pin and bushing parts. It is made of S355MC steel material, 20MnB4 alloy steel and F-0000-10 powder metal iron for movable/fixed wing, axis pin and bushing, respectively (Figure 2). After the prototype hinge has been designed, fixed and movable wings were produced by laser cutting and cold forming (Figure 3).Cold forging and sintering processes have been used for axis, bush, respectively. Each part has been assembled by riveting process as shown in Figure 2.

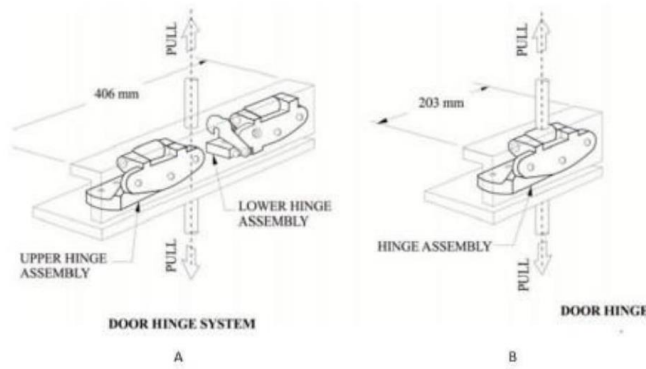


**Figure 2:** Parts and materials of prototype hinge



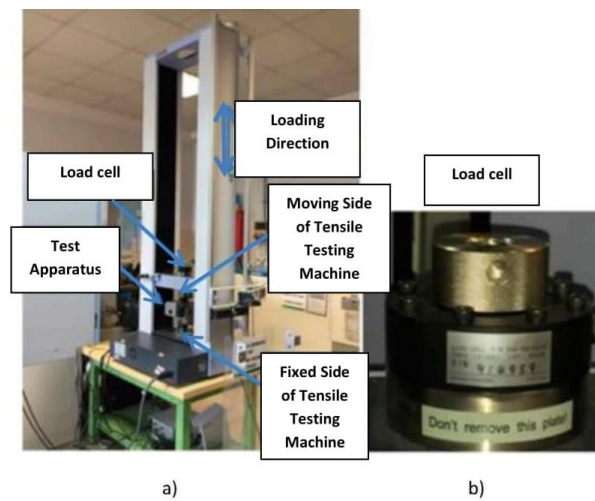
**Figure 3:** Materials of prototype hinge and parts

Two types of test apparatus have been indicated at UNECE R11 regulation. These are named as door hinge system and door hinge (Figure 4). It is also indicated in specification that one of these test apparatus can be chosen during tests depending of tensile test machine. In this study, door hinge apparatus has been used because of the symmetrical hinges of door system. For all type of apparatuses, dimensions are shared in Figure 4. In the specification, a thickness of apparatus is not indicated but they must be rigid. Additionally, the apparatuses have been mounted to tensile test machine from the center of hinges' axis. The forces of the experimental tests are used 50% less than the loads in the regulation due to the door hinge apparatus and hinges are fixed to apparatus by using M8 screw-nuts with 21 Nm torque.



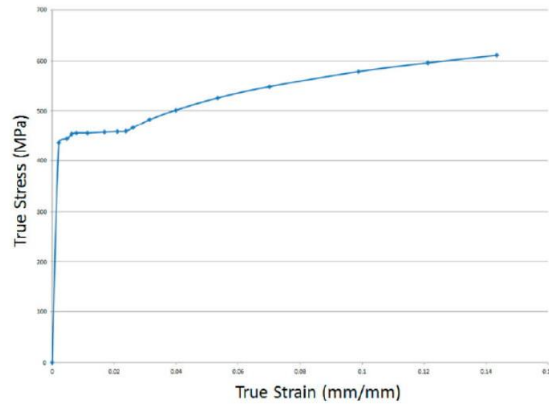
**Figure 4:** Test apparatus types A) Door hinge system B) Door hinge

After the prototype hinge was designed and manufactured, it is subjected to load cases as given in Figure 5a and 5b. Shimadzu Autograph AGS-X tensile testing machine shown in Figure 5a and 5b is used with loadcell of 50 kN capacity and tensile tests were performed in longitudinal, transversal and vertical directions. Also the tensile tests are also performed at a speed of 5 mm/min. Force- displacement curves are generated during loading by means of the load cell shown in Figure 5b.



**Figure 5:** Test system a) Tensile test machine b) Loadcell

Additionally, material properties of fixed and movable wings (S355MC) have been investigated by tensile test which is in accordance with American Society for Testing and Materials E8/E8M standard. The gathered engineering stress and strain curves have been converted to true stress strain curves to use in FEA calculations as shown in Figure 6.



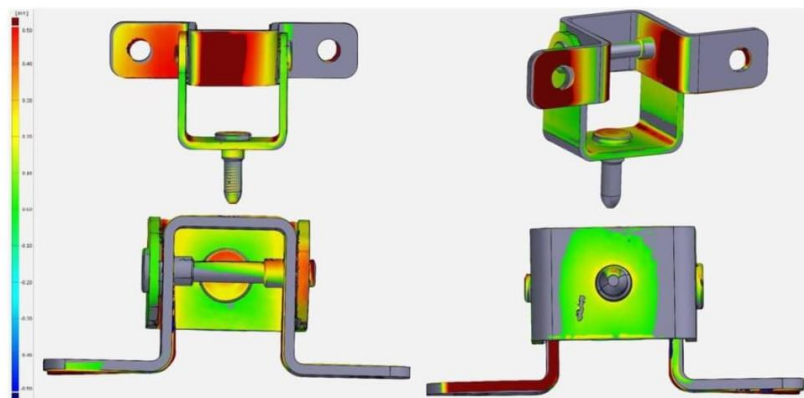
**Figure 6:** True stress strain curves of S355MC

**3. FINITE ELEMENT SIMULATION**

The simulation study has been conducted with two different CAD data of same hinge samples. The first data has been designed with nominal dimensions of the prototype door hinge by using Catia. The second data has been created from 3D scanned data by using stl file and Spaceclaim module. The 3D scanning has been performed by using Atos 3D scanner and GOM inspect 2017 software has been used to see the effect of geometrical differences in the prototype door hinge produced.

The obtained geometric differences according to the results of the 3D scanner are shown in Figure 7. According to the Figure 7, colors from green to red indicate areas outside the reference geometric data, and colors from green to dark blue indicate areas within the reference geometric data. Thus, a difference of 0.2 mm was observed on mounting area of fix wing as issue of surface flatness due to lack of blank holder during U shape bending process of the fix wing. It has been seen that a blank holder was not used in Figure 3

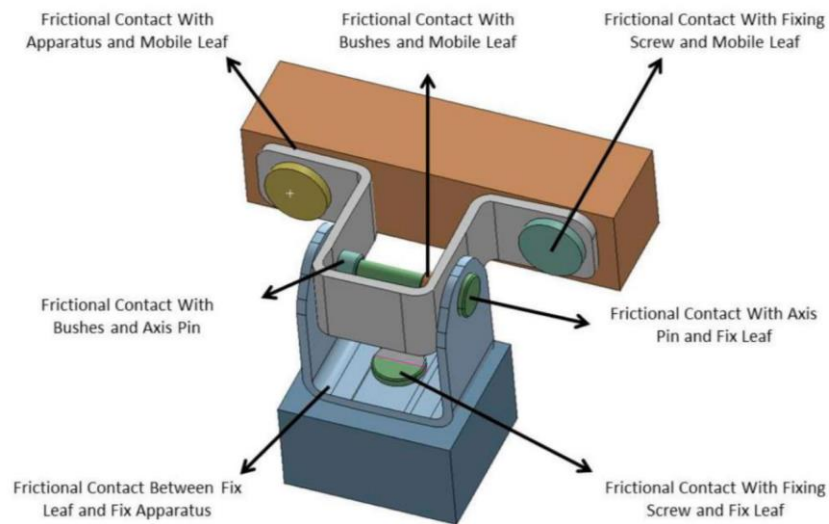
Also the fix wing has been observed that the fix wing deformed 0.2 mm to one side. Riveting process of axis given in Figure 2 has been considered as a root cause of this deforming issue. In addition, misalignment has been observed in the axis pin given in Figure 2. The root causes of this difference are the fixed wing with axis that does not overlap properly, and the axis pin mounting holes thereon. Due to the deformation, it has been also determined that the wings of the movable part are approaching each other. This occurred during the bending of the movable part. As a result, it has been concluded that there were significant differences between the CAD model and the 3D scan model. Therefore 3D scan data was converted to CAD data by Spaceclaim module to inspect impact of differences to force and displacement results. During the creating of the 3d scan model, stl file has been used as reference file and imperfect data has been drawn by taking several cross-sections on stl file.



**Figure 7:** 3D scan results of produced hinge sample

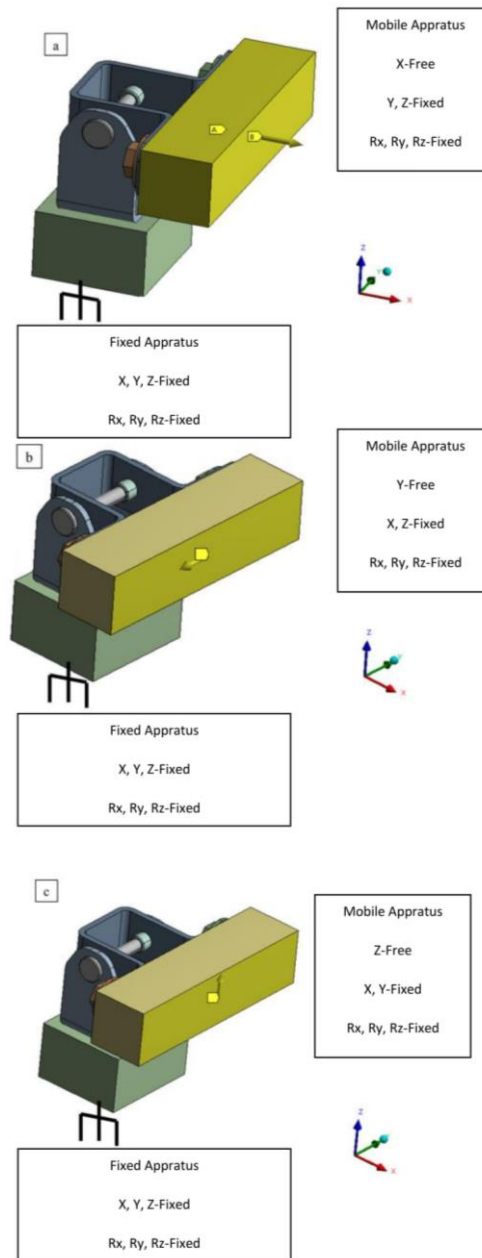
Linear finite element analysis with different mesh structure and algorithms has been also performed. However, no specific effect has been observed on the results. Therefore mesh properties has been chosen in order to have best computational efficiency with accuracy. Thus, hex20 and tet10 element are used in the movable wing, fixed wing, axis pin and tet10 mesh element is used in the mobile and fixed apparatus. 1.5 mm mesh size (2 elements in thickness) has been assigned for the fix and movable wings. 1 mm mesh size has been applied for axis and bushes and 5 mm mesh size was used for the mobile and fixed apparatus. Therefore the finite element model of cad model had 134 730 nodes, 44 601 elements and finite element model of 3d scan model had 145 196 nodes, 47 366 elements in the study with indicated mesh settings.

In the study, friction coefficient was determined as 0.2 and ‘frictional contact type’ is defined between the surfaces shown in Figure 8. In order to avoid convergence issues, pure penalty contact algorithm has been defined with 0.6 contact stiffness value and this value has been updated at each iteration during the analysis. Also, displacement driven loading has been used at load cases different than literature, this boundary condition has been applied to the mobile apparatus instead of directly applying to the hinge and the fix apparatus has been fixed in 6 degrees of freedom as shown in Figure 9. Also isotropic material data has been used by defining heir linear elastic side and plastic deformation side of the tensile curve of material as shown in Figure 6.



**Figure 8:** Contact definition of fea model





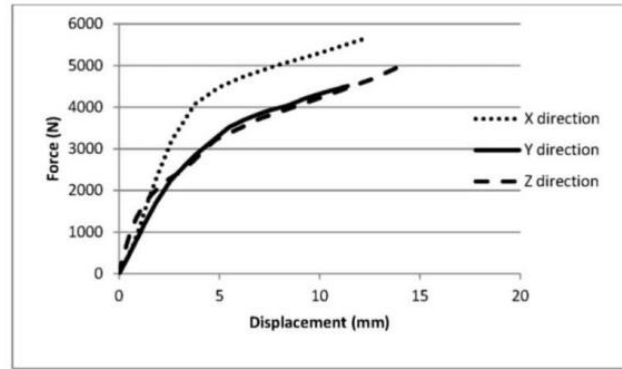
**Figure 9:** FEA model boundary conditions a) X direction b) Y direction c) Z direction

Additionally, Implicit solver has been used on Ansys Workbench 18 for finite element simulations. All simulations have been performed considering the large deflection effect and the default convergence criteria of Ansys mechanical software are accepted.

#### 4. RESULTS AND DISCUSSION

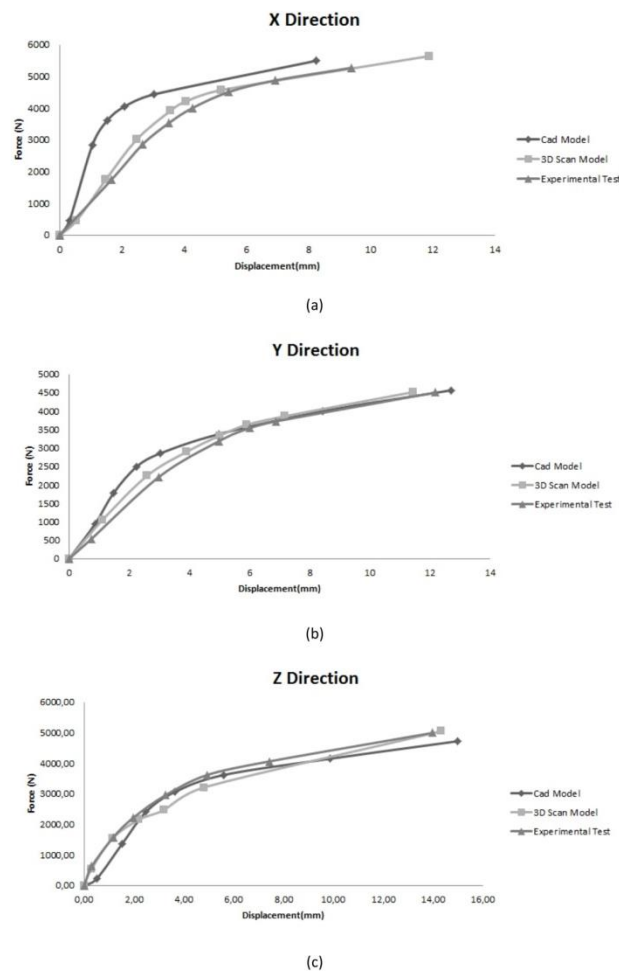
In this study, the displacement was applied to the prototype vehicle hinge according to UNECE R11 regulation and force-displacement curves are obtained and shown in Figure 10. According to experimental results, no separation deformation has been observed in the vehicle door hinges and the hinges met the UNECE R11 specification criteria.

The Force-displacement curves from experimental tests and simulations are compared with each other in Figure 11. According to nominal CAD results (the first data), it is observed the most difference with results in X direction. For Y direction, most of the difference has been observed at linear stage of tensile test and Z direction, incompatibilities are observed at the beginning and late stages of tensile curves. Also we have observed a reduction at incompatibilities drastically when we did same comparison between data created



**Figure 10:** Experimental force-displacement curves for loading directions in UNECE R11 specification

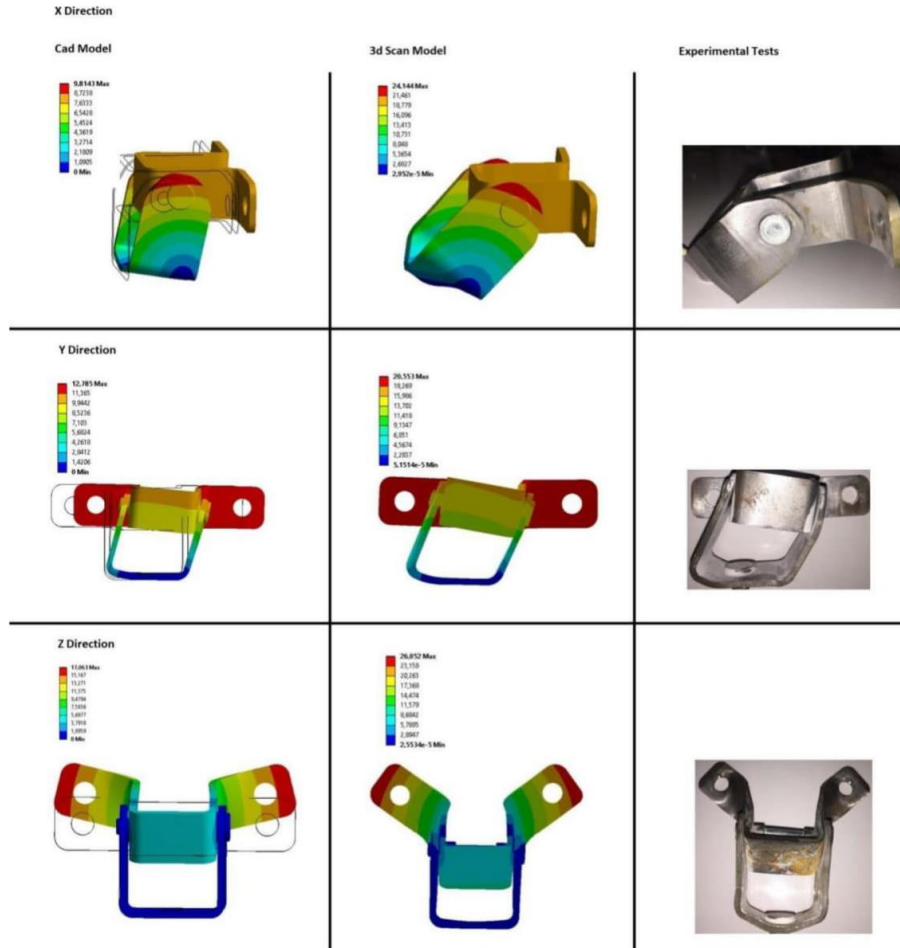
from 3d scan (the second data). For loading in X direction, it has been observed that flatness of mounting surfaces have a critical impact on convergence of test and simulation results. Also it has been observed that same flatness issue affects force-displacement results in Y direction. It is considered as 0.2 mm gap between mounting surface and apparatus affects general stiffness of the system and make reduce it intensely. For loading in Z direction, it has been observed that deformation of mobile part effects contact surface area and add extra force under pretension. This situation directly affected frictional forces on mobile contact surfaces and increased the force displacement results at the linear section of the curve and increasement of the curve.



**Figure 11:** Comparison of the experimental and simulation results a) X direction b) Y direction c) Z direction



On the other hand, the results of the deformation of the hinges after the simulations and the photographs of the tensile test performed on the hinges are shown in Figure 12. Accordingly, while a large difference was observed between the Cad model and the experimental model, this difference was corrected by the 3d scan model.



**Figure 12:** Comparison of the total deformation results of the cad and 3d scan model with experimental results

### 5. CONCLUSIONS

This study has been conducted for the purpose of compliance of simulation results with test results. In the study, the effects of the Cad and the 3d scan models of a sheet metal prototype vehicle door hinge on the tensile tests have been examined in all X, Y and Z directions according to UNECE R11 regulation. The finite element simulations showed that there has been no similarity between the cad model and the 3D scan models in terms of deformation when compared with experimental results. Also, it has been considered that flatness of mounting surfaces show strong relationship to these differences of results and evidences have been observed at production process as the reason of this flatness issue.

In this study, it was concluded that every finite element simulation performed should be supported by the experimental tests. Since the results obtained in the finite element analysis may differ according to the physical conditions, it may be inadequate to perform it alone. Additionally, quick and cheap correlation approach was shown to industry and reference model were shared with researchers to use them in their study.

## 6. REFERENCES

- [1] CHIANG, Y.J., AKHTER, A., WANG, Y., *et al.*, “Robustness in Angular Rigidity of Automotive Side-Door Hinges”, *SAE Technical Paper*, v.1736, pp. 291-298, 2003.
- [2] BAO, J., DING, Y., HU, S., *et al.*, “Research on Intelligent Layout of Door Hinge Based on CATIA CAA”, *SAE Int. J. Commer. Veh.*, v.7, n.1, pp.132-140, 2014.
- [3] ZHANG B., YU,W., WANG, Y. “The Axis Design and Layout of Automotive Door Hinges”. In: Society of Automotive Engineers of China (SAE-China) (eds.) Proceedings of SAE-China Congress 2014: Selected Papers. Lecture Notes in Electrical Engineering, pp.1-13, Springer, Heidelberg, 2015.
- [4] KOVACEVIC, D. SPRECIC, D., HALILOVIC.,*et al.*, “Automotive Bonnet Hinges shape optimization using linear Fe simulation and comparative method”, *J. Trends Develop. Mach.Assoc.Technol.* v.21, pp. 109-112, 2018.
- [5] TOAN, N.D., SEOGO, C., JUNYOUNG, P., *et al.*, “Finite Element Method Simulations to Improve Press Formability of Door Hinge”, *J. of Materi. Eng. and Perform.*, v.18, 2009.
- [6] LEE, S.J., LEE, K.H., KIM, B.M. “Design of Roll Profile for Complex Shape in Shape Rolling by Combined 3D-EFA and BWT”, *Int. J. Precis. Eng. Manuf.*, v.16, 2015.
- [7] TUFEKCI, M., KARPAT, F., YUCE, C., *et al.*, “Design optimization of aluminum hinge parts for lightweight vehicles: Performance, durability and manufacturability”, *Int. J. Mech. Prod. Eng.*, v. 3, pp.6-13, 2015.
- [8] MORE, N.D., JADHAV, T.A, “Stress Analysis and Optimization of Car Door Hinge”, *International Engineering Research Journal (IERJ)*,pp. 1202-1205, 2016.
- [9] YILMAZ, T.G., TUFEKCI, M., KARPAT, F., “A study of lightweight door hinges of commercial vehicles using aluminum instead of steel for sustainable transportation”, *Sustainability*, v.9., 2017.
- [10] DOGAN, S., GUVEN, C., KARPAT,F.,*et al.* "Experimental Verification and Finite Element Analysis of Automotive Door Hinge". Proceeding of the ASME 2014 International Mechanical Engineering Congress and Exposition, p14-20.
- [11] Otomobil Kapı Menteşesinin Bilgisayar Destekli Tasarımı , Analizive Doğrulanması. <http://otomasyondergisi.com.tr/arsiv/yazi/101-otomobil-kapi-mentesesinin-bilgisayar-destekli-tasarimi-analizi-ve-dogrulanmasi>. Accessed in 01 March 2020.
- [12] DESAI, A.D., BALDEN H.V. "Interior Noise Investigation of Idealized Automotive Vehicle with Bolted Door Hinge Connections". Proceeding of ABAQUS User's Conference ,pp 225-239.
- [13] BEKAH, S. "Fatigue Life Prediction in Door Hinge System Under Uni-axial and Multi-axial Loading Conditions", Msc. Thesis, University of Ryerson, Canada, 2004.
- [14] PATIL, K.R., KHODKE, R.M., SASIDHARAN, A. “Door Sag Evaluation of Clothes Dryer by Using FEA and Influence of it on Effectiveness of Door”, *International Research Journal of Engineering and Technology*, v. 4, pp 2997-3003.
- [15] LU, Y., LAI, J., FENG, Y. “ The Modeling and Simulation of Collision Protection system Between the Driver of Non-motor Vehicle and Car Door”, *EURASIP Journal on Wireless Communications and Networking*, DOI: <https://doi.org/10.1186/s13638-018-1123-4>
- [16] SHINDE, S.A., NAVTHAR, R.R, “Vehicle Door Sag Evaluation Usin FEA”, *International Journal of Engineering Research and Development*, v. 11, issue 03, pp 21-26, 2015.
- [17] RAZAK, T.A.A., HAMID, M.N.A., GHAZALI,A.M., *et al.*, “A Stress Analysis and Design Improvement of a Car Door Hinge for Compact Cars”, *Engineering Applications for New Materials and Technologies*, v. 85, pp 151-161, 2018.
- [18] MUNDE, K.H., WAGH, V.W., “Fatigue Analysis of Automotive Door Hinge to Avoid Sagging of Doors”, *Journal of Emerging Technologies and Innovative Research*, v. 6, issue 1, 2019.
- [19] DEMIRCI, E., GULER, T., YILDIZ, A.R., “Lightweight Design of an Automobile Hinge Component Using Glass Fiber Polyamide Composites”, *Material Testing*, v. 60, issue 3, pp 306-310, 2018.
- [20] BHASKAR, N., RAYUDU, P., “Design and Analysis of a Car Bonnet”, *International Journal of Current Engineering and Technology*, v. 5, pp 3105-3109, 2015
- [21] United Nations Economic Commission for Europe (UNECE). <https://www.unece.org/fileadmin/DAM/trans/main/wp29/wp29regs/2013/R011r2e.pdf>. Accessed in 3 October 2019.

## ORCID

Hande Güler Özgül  
Onur Erol

<https://orcid.org/0000-0001-8589-6931>  
<https://orcid.org/0000-0002-4530-9234>