



ENGINEERING SCIENCES

Analysis and numerical simulation of the sterilization of low-calorie grape jam

MARIANA B. LABORDE & ANA MARÍA PAGANO

Abstract: The objective of this work was to analyze and defined an appropriate heat treatment for the sterilization of a low-calorie grape jam (39.26 ± 0.63 °Brix; pH 3.63 ± 0.04) obtained using fruits reduced in carbohydrates by optimized pretreatment, and natural Stevia sweetener to replace sucrose. For this purpose, different types of information and tools were used. The physicochemical characteristics and proximal composition of the jam were determined. Information as to what microorganisms as common saprophyte fungi in grapes can develop in these products was gathered from the available literature. The thermophysical properties of the product were determined. Different combinations of recommended time and temperature combinations for heat treatments that inhibit microorganisms were analyzed. FEM numerical were developed to predict temperature profiles during heat treatment. Also, microbiological analysis of yeast and yeast screening and counting was performed. As a result of this study, two heat treatments were proposed to inhibit the fungus *B. fulva* and *B. nivea* (common in grapes). Two autoclave sterilization processes (121.1°C ; $20\text{-}32\text{ lb/in}^2$) were defined by the time-temperature combinations, T1: 100°C -5 minutes; T2: 100°C -10 minutes, to apply and maintain the desired temperature of 100°C throughout the product for 1.3-27 seconds. Both treatments were considered suitable for sterilizing a 190 g jam container and were validated by microbiological analysis.

Key words: Low-calorie jam, rose grape, thermal treatments, finite elements method, temperature profiles.

INTRODUCTION

The high consumption of sugars directly or indirectly through food has always been related to the increasing of blood glucose level, weight gain, increased demand for B vitamins, the development of dental caries (tooth decay), among other health disorders (Blanco Anesto 2002). Given this, several global health organizations (WHO, FAO) propose recommendations and strategies to reduce sugar intake, while promoting the consumption of healthy foods (fruits, vegetables, dried fruits, seeds, yogurt). Under these guidelines, an innovative product obtained through emerging technologies was formulated and developed: a

low-calorie jam using fruits reduced in its natural sugars (Laborde et al. 2018) and a Stevia calorie-free natural sweetener, instead of sucrose, to achieve a product of minimal glucidic value without chemical additives (Laborde 2019).

The reduced carbohydrate jams belong to the group “Foods modified in their glucidic composition” (“*Alimentos modificados en su composición glucídica*”) established by the Argentine Food Code (CAA 2018). In the process of obtaining traditional sucrose-based jams, both hermetic packaging and high sugar inhibit microbial development and degradation due to increased osmotic pressure, extending the shelf-life and storage time of the product (Lespinard

et al. 2009). But for low-sugar jams, additional barrier technologies, such as sterilization or pasteurization heat treatments, are required to achieve microbiological stability. It is known that bacteria can live in both hypotonic and hypertonic environments, due to the protection of a rigid cell wall and the semi-permeable cytoplasmic membrane. Normally the cytoplasm of the bacteria has a slightly superior osmolarity to that of the environment, which guarantees the maintenance of water inside. However, when the medium is very hypertonic as is the case with traditional jams with 65 to 68% soluble solids or Brix grades, these mechanisms of the bacteria are unable to prevent the loss of water which leads to a retraction of the cytoplasmic membrane. The loss of water can lead to dehydration of the cytoplasm, which leads to the halting of growth (Iáñez 2005). In contrast in sugar-reduced jams, osmotic pressure is not sufficient to have this control effect on the development of microorganisms, requiring other barriers such as sterilization to ensure the safety of the product in storage.

The thermal treatment of food is intended to eliminate and inhibit (partially or totally) the enzymes and microorganisms that can alter the product. To determine the heat treatment time that food must undergo to achieve microbiological safety, it is necessary to know the resistance of the microorganisms, as well as the enzymes present in them. Also, many of the characteristics of food, such as water content (moisture, water activity), fats, proteins, carbohydrates, and pH, affect the heat resistance of the microorganisms potentially present. The pH of the food is one of the most important factors in defining the heat treatment to be applied. In this sense, foods are classified as acidic ($\text{pH} \leq 4.6$) or low acidity ($\text{pH} > 4.6$) (ICMSF 2005). Reduced-calorie grape jam belongs to the food group with high acidity (Laborde 2019)

so that at this pH, the bacterium *Clostridium botulinum* and its spores cannot develop (Tornese et al. 2008, Gómez-Sánchez 2007, Cereser et al. 2008).

Another element that can be very useful to establish the most suitable heat treatment to apply to hermetically packed foods is to know the temporal behavior of the product temperature at the point farthest from the heat source (thermal center). The heat transfer rate data during heat treatment usually called the heat penetration curve as a function of the applied temperature allows determining the time needed to reach the sterilization temperature throughout the product.

To evaluate the temporal evolution of the temperature during the heat treatment, the modeling and simulation of the process is a valuable tool, since it allows to quickly determine the distribution and evolution of the temperatures in the product, minimizing experimental procedures, reducing costs and times (Lespinard et al. 2009). Many researchers have tested the advantages of simulation tools to predict food behavior during heat treatments (Lespinard et al. 2009, Augusto et al. 2010, Ansorena & Salvadori 2011, Singh et al. 2015, Wang et al. 2017, Garg 2019, Karpińska-Tymoszczyk et al. 2020).

Furthermore, it should be borne in mind that, although pasteurization and sterilization processes applied to food ensure its safety, they may also cause loss of nutritional value and confer undesirable characteristics on its flavor, texture, color, and other properties (Lespinard et al. 2009, Asorena & Salvadori 2011, Igual et al. 2015, Kaushik et al. 2018). Then, it is necessary to select suitable combinations of time and temperature to ensure the microbiological quality of the product, minimizing these undesirable effects on the nutritional properties, functional

attributes, and organoleptic characteristics of the food.

This paper addresses the problem of defining the appropriate heat treatment for the product developed, a reduced-calorie grape jam, depending on the characteristics of the medium.

MATERIALS AND METHODS

Raw materials and procedure to obtain low-calorie grape jam

To obtain the low-calorie grape marmalade based on natural sweetener Stevia, grapes (*Vitis vinifera* L.) of the *Red Globe* variety reduced in their caloric sugars by pretreatment of ultrasound-assisted osmosis (Laborde et al. 2018, Laborde 2019), were used. This optimized process significantly reduced the content of the main carbohydrates of the grape, by 30% fructose and 27% glucose. The formulation of jam (from pretreated grape, pectin of low-grade methoxyl, citric acid, and natural Stevia-based sweetener) was defined based on bibliographic information and preliminary sensory acceptance tests obtained to evaluate sweetness (central location test) (not shown here) (Laborde 2019). It is important to note here that the sensory analysis was performed according to the requirements of the ethical committee of the Institution Universidad Nacional del Centro de la Provincia de Buenos Aires (UNICEN), and the samples were prepared by researchers who approved the Official Course of Safe Food Handling (“Curso sobre Manipulación Segura de Alimentos”) of the Ministry of Health (ANMAT, Argentina) with a manipulator card (“carnet de manipulador de alimentos”) valid at the time of the trial.

In the process of obtaining the jam, the cooking of the product ended at the moment of achieving a concentration of soluble solids

of 39-40 °Brix (Barrantes Salas 2009, Codex Alimentarius 2009) at a temperature of 105-106 °C (INTA 2018a, b). Once the endpoint of the jam was reached, the product was filled hot (98 °C) in standard hexagonal-faceted glass jars (190 cm³ capacity, with half-fold lids) (Figure 1) and the containers were closed immediately. The containers were previously sterilized and tempered in an oven to avoid thermal shock with the hot product. The filling of the jars was carried out until reaching a level that allowed to leave a free space of 1 cm up to the top edge of the container. This space called “headspace” is very important so that the hot-packed product can generate a vacuum when it contracts once cooled, further assuring the sealing conditions of the container. Immediately after filling the containers were covered and inverted. This practice was done to ensure that the air in the headspace is sterilized as it passes through the hot product mass. It also helps the evaporation culminate in the bottom of the bottle, and then, by returning the container to the normal position, the small condensation at the bottom will be in the absence of oxygen, with reduces the likelihood probability of bacteria developing.

In the sterilization treatment, the freshly filled containers can be placed in a water bath submerged in warm water in a pot with a canvas or wood base to dampen the movement of the jars. The jars should be placed with the lid up, preventing any spaces between them, locking them so that they do not shake or hit during the boil, thus avoiding the possible breakage of the containers. Containers must cover with water to a level that is not less than 2-3 cm above the lid of the container and kept in the bath at 100 °C from the time it boils until the necessary sterilization time. A few drops of citric acid can be added to the bathwater to avoid stains that could appear on the glass due to the hardness of the water. Meanwhile, for the sterilization

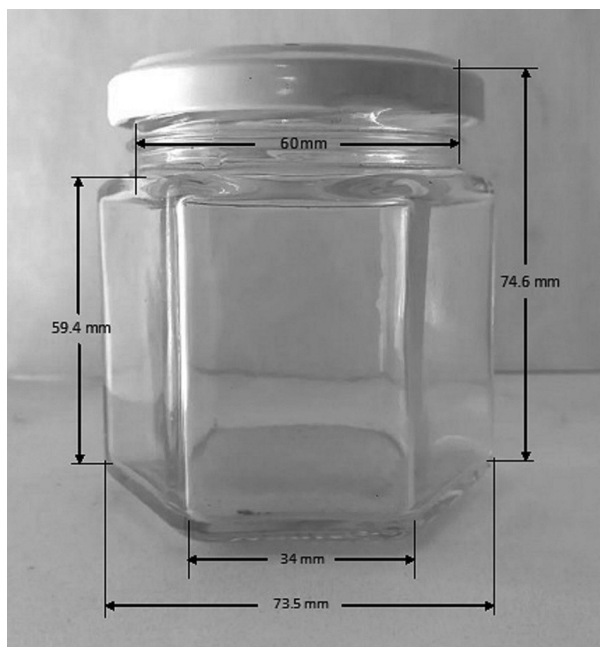

Figure 1. Hexagonal glass container with a half screw metal lid used to pack low-calorie Red Globe grape jams.

treatment, the freshly filled containers with the hot product are autoclaved according to the same considerations mentioned for sterilization regarding their arrangement and arrangement in the baskets of the sterilizing equipment. The necessary sterilization time begins to be counted from the moment the autoclave reaches 121.1 °C.

The proximal composition (water, proteins, ashes, and carbohydrates as the main components), pH, and soluble solids content (°Brix) of the reduced-calorie jam were determined according to the methodology described below.

Determination of humidity

It was determined by drying in a forced convection oven at a temperature of 70 ± 1 °C to constant weight, on a 5 g sample, in triplicate (an adaptation of method 934.06, AOAC 2000).

Determination of protein content

Protein content was performed using the Kjeldahl method of AOAC 920,152 (AOAC 2000).

Determination of ash

The ash content was determined by combustion of the sample (5 g) in the muffle at 550–600 °C, in two replicates (an adaptation of method 923.03, AOAC 1980).

Determination of carbohydrate content

The carbohydrate content was determined by subtracting the water, protein, and ash masses from the total mass of the sample; the fat content was assumed to be negligible (Manrique 2020).

Determination of pH

It was determined by a pH meter. The automatic pH meter was calibrated with pH 7 and 4.1 buffer solutions. Approximately 10 g of sample was weighed, 100 mL of deionized water was added and it was homogenized for a few minutes. The pH meter (pH-Meter Orion 720-A, Boston, USA) was introduced and read when the equipment stabilized (SENCAMER 1979).

Determination of soluble solids content

It was determined by refractometry (ABBE Atago 89553 Zeiss refractometer, precision ± 0.01 °Brix). A small portion of crushed fruit was diluted with water and the refractometric reading was multiplied by the dilution factor (NMX-F-436-SCFI 2011).

Definition of the sterilization process

To define the most appropriate sterilization treatment (time-temperature combination) for the final product, different methodological tools were used:

- i) Analysis of possible thermal treatments to be applied to low-calorie jam, based on bibliographic data on the inhibition of saprophytic microorganisms of the grapes, could potentially be present in the product.

- ii) Development of numerical models to predict the temperature in the product container's thermal center through a non-stationary simulation of the thermal process to estimate the treatment time necessary for the entire product to reach the selected sterilization temperature.
- iii) Microbiological tests of fungal and yeast count in sterilized products obtained by applying the sterilization times resulting from the analysis of the previous items (i) and (ii).

Analysis of sterilization time based on bibliographic data

As mentioned, foods are classified into low acid foods ($\text{pH} > 4.6$) and acidic foods ($\text{pH} \leq 4.6$) according to the level of acidity (ICMSF 2005). In turn, by applying another widely used classification that unfolds the second set mentioned above, foods can be divided into three groups: low acidity foods ($\text{pH} > 4.6$), acidic foods (pH from 3.7-4.0 to 4.6), and high acidity foods ($\text{pH} < 3.7-4.0$) (Jay 1992). This consideration regarding the acidity of food is essential at the time of its preservation in hermetic containers since a pH value of 4.6 or less completely inhibits the growth of the anaerobic bacterium *Clostridium botulinum*, but above that level, the risks are significant (ICMSF 2005, Gómez-Sánchez 2007, Ansorena & Salvadori 2011). Low pH contributes in two ways to the preservation of a packaged food: either because microbial growth is inhibited under these conditions, or because the acidity of the food reduces the thermal resistance of microorganisms potentially present in the product during the applied thermal processing for its conservation (ICMSF 2005, Gómez-Sánchez 2007). Microorganisms have different resistance to heat treatment: psychrophiles are the most sensitive to heat, followed by mesophiles, while thermophiles are the most resistant to heat.

According to the classification mentioned above about pH, the jam developed in the present work under the conditions described has a high acidity (its pH turned out to be 3.63 ± 0.04 , shown later). Thus, the probability of *Clostridium botulinum* spores in the product would be unlikely since this bacterium does not grow at a pH below 4.6 (Jay 1992). However, in this product, there is the possibility of developing other microorganisms such as molds and, to a lesser extent, yeasts and mesophilic spore-forming bacteria (Schmitt 1966, Stumbo 1973, Salomão 2002, Gómez-Sánchez 2007, Athayde de Souza et al. 2012). Considering that these microorganisms are biological agents that can potentially be present in the low-calorie grape jam, and cause a deterioration in the quality of the product, the conditions necessary for their inactivation were explored to define one (or two) possible heat treatments (s) suitable (T1, T2 if any) for autoclaving the product.

Development of numerical models of temperature prediction during heat treatment

During heat treatments applied to packaged foods, the rate of heat penetration depends on the nature of the product, which defines the dominant mechanism of heat transmission. The jam was assumed to be static, thereby heat is transferred only by conduction. Non-steady-state conductive heat transfer during autoclave sterilization treatment applied to low-calorie grape jam was described by the Second Fourier Law (Bird et al. 2006, Lespinard et al. 2009, 2012).

The purpose of this approach was to estimate the time required to reach the preselected temperature in the thermal center of the packaged product during the heat treatment applied immediately after packaging the product in the bottle. This condition will ensure that the thermal center of the container reaches the temperature necessary to destroy

microorganisms and guarantee the safety of the product.

To achieve this goal, computational numerical models were developed to predict the temporal distribution of temperature throughout the product and, especially, from the thermal center of the container, a place farther from the heat source. These models, based on the Finite Element Method (FEM), were developed to simulate conductive heat transfer during heat treatment by autoclaving the packaged product in an airtight glass container with a twist-off cap.

To define the thermal properties of the marmalade, temperature-dependent correlations of the components present in their proximal composition were used.

The model predictions were used to verify that the sterilization program(s) (combination(s) of temperature and time), selected based on the analysis of the available bibliographic information, guarantee the microbiological quality of the product.

Microbiological tests to evaluate the effectiveness of the thermal treatment

To analyze the effectiveness of the sterilization treatment (s) applied to the packaged product, the fungus and yeast count was performed on the sterilized jams under the selected temperature and time conditions. The objective was to obtain information on the microbial load of the product to validate (or not) the thermal process (es). The analysis of these microorganisms was performed since they are the most likely to proliferate in the product. To carry out these determinations, the methodology described below was used.

APD medium (potato dextrose agar) was used. This is a general medium for the growth of these microorganisms (fungi, yeasts) that has the advantages of its low cost and simple formulation. This medium is normally supplemented with acids or antibiotics to inhibit

bacterial growth. The use of APD acidified with tartaric acid was based on references that report the use of this medium (Quevedo-Preciado et al. 2005, Da Rocha Ferreira et al. 2011, Huacuz et al. 2013).

For the preparation of the medium, an infusion of potatoes was prepared by boiling 200 g of potato with the peel (previously washed with a brush) in 1 L of distilled water. It was boiled for 30 minutes and then filtered through a cheesecloth. Then the volume was rinsed again adding distilled water up to obtain 1 L of solution, and 20 g of dextrose and 20 g of powdered agar were added (FDA 2001). The preparation was homogenized and boiled until clarification. The medium was then autoclaved at 121.1 °C for 15 minutes.

On the other hand, a 10% tartaric acid solution was prepared and it was also autoclaved at 121.1 °C for 15 minutes. Petri dishes were prepared with 20 mL of APD and 0.3 mL of 10% tartaric acid was added to obtain a final pH of 3.5 (Camacho et al. 2009).

For the preparation of the jam samples to be incubated, 11 g portions of the product were taken and diluted in 99 mL of water with 0.1% peptone (initial suspension: 10-1). This mixture was properly homogenized and then dilutions were made, transferring 1 mL of the initial suspension to tubes with the required volume of diluent to obtain other decimal dilutions (10-2, 10-3, and 10-4).

The surface seeding method was applied, inoculating the different decimal dilutions of the samples in duplicate. The samples were incubated at $25\text{ °C} \pm 1\text{ °C}$ for 5-7 days. A preliminary count and observation of the evolution of the plates were performed at 5 days. For expression of the results, plates having between 10 and 150 colonies were preferably selected. In all cases, the count was performed according to ISO 7218: 2007 (ANMAT 2014).

RESULTS AND DISCUSSION

Results of the characterization of low-calorie grape jam

Table I shows the proximal composition and other physicochemical properties of the jam obtained from reduced-calorie grapes and Stevia.

As can be seen, the low-calorie grape jam presented a low pH, intermediate humidity, and meets the required Brix degrees for products modified in their glucidic composition (Codex Alimentarius 2009).

To design a thermal process, a reference microorganism must be taken as the basis. The selection of the microorganism must be such that it guarantees the destruction of the other pathogenic microorganisms less resistant to heat that may be present (Garro Mena 2007). Therefore, for the selection of the appropriate heat treatments to be applied to the low-calorie jams of grapes obtained by substituting sugars for Stevia, an analysis was made of the potential microorganisms that could develop depending on the characteristics of the medium.

Among the common saprophytic molds of grapes, it is possible to find heat-resistant fungi of the genus *Byssochlamys*; these microorganisms are aerobic but can grow at low oxygen concentrations (King et al. 1969,

Beuchat & Rice 1979, Gómez-Sánchez 2007, da Rocha Ferreira et al. 2011, Nguyen 2012, Santos et al. 2018). Both in healthy and deteriorated grapes, the species *Byssochlamys fulva* has been detected predominantly (Silva 2015), and less frequently, *Byssochlamys nivea* (Beuchat & Rice 1979, King et al. 1969, da Rocha Ferreira et al. 2011, Santos et al. 2018). These fungal strains can grow at very low oxygen concentrations (such as those present in the headspace of hermetically packaged jams), allowing the production of enzymes that degrade pectin and leading to loss of technological quality of the gel. Furthermore, these fungi can generate gas (CO₂) production. In addition to affecting the quality of food due to its visible mycelia formation and the production of pectinolytic enzymes, some heat-resistant fungi can cause health risks due to their ability to produce mycotoxins. Important examples include patulin, bisotoxin, malformins, and isocyclic acid produced by *Byssochlamys* sp. (Beuchat & Rice 1979, Gómez-Sánchez 2007, Santos et al. 2018). Another danger associated with the development of these species is that their metabolism can cause an increase in the pH of the medium, facilitating the growth and production of *Clostridium botulinum* toxin (Odlag et al. 1978, Gómez-Sánchez 2007).

Byssochlamys fulva and *B. nivea* are heat-resistant fungi that can cause spoilage in a

Table I. Proximal experimental composition and other physicochemical properties of Red Globe low-calorie grape jam.

	Component/Property	Content/Value
Proximal composition (%)	carbohydrates	42.61 ± 5.17
	proteins	0.99 ± 0.01
	ash	1.04 ± 0.17
	water	56.26 ± 4.99
Physicochemical properties	pH	3.63 ± 0.04
	soluble solids (°Brix)	39.26 ± 0.63

variety of canned fruit products (Nguyen 2012). For these heat-sensitive species, inactivation treatment times of 3 to 0.24 minutes have been determined at temperatures in the range of 85-121 °C for nectars, canned fruits, binary mixtures of star fruit pulp, and mango, although the treatment depends on the initial number of microorganisms and the characteristics of the food itself. However, several researchers have reported that *B. fulva* strains have marked differences in heat resistance according to their environment (King & Whitehand 1990, Gómez-Sánchez 2007, Athayde de Souza et al. 2012). Beuchat & Rice (1979) reported that some strains of *Byssochlamys* can easily withstand a 15-minute treatment at 85°C.

Da Rocha Ferreira et al. (2011), working with fruit nectars (pineapple and passion fruit), determined that a heat treatment at 98°C for 27 minutes allows the *Byssochlamys nivea* fungus to be inactivated, more resistant in this medium than *Byssochlamys fulva*, which only requires 13.6 minutes at the same temperature, with z values for these species of 5.4 and 5.5°C, respectively. However, this behavior of higher resistance of *B. nivea* compared to *B. fulva* is not generalized. Other authors have determined opposite results regarding the thermal resistance of these microorganisms in the same medium (Gillespy & Thorpe 1962, Put & Kruiswijk 1964) and also when comparing different media (King et al. 1969). Athayde de Souza et al. (2012) reported that the high concentration of soluble solids in pineapple and mamon fruit juices seems to have a protective effect on *B. nivea* spores, increasing their thermal resistance, possibly indicating that the reduction in the activity of the water protects them.

The ascospores of certain molds (spores produced in the ascites or sex cells of the ascomycetous fungi), particularly from the genera *Byssochlamys*, *Neosartorya*, *Talaromyces*,

and *Eupeccillium*, can survive in canned fruits (pears) after the heat treatments used in the industry (Splittstoesser 1996, Pitt & Hocking 1997, Gómez-Sánchez 2007). It has also been shown that the heat resistance of the *B. nivea* and *B. fulva* ascospores depends fundamentally on the environment in which they are found (Beuchat & Toledo 1977). They can be inactivated much more quickly at 90 °C in a phosphate buffer without sugars than in 16 °Brix tomato juice, which shows that some components of tomato juice (sugars, for example) would have a protective effect on ascospores during warming, influencing its inactivation rate (Gómez-Sánchez 2007), as demonstrated by Athayde da Rocha et al. (2012) in other fruit juices. The *B. fulva* and *B. nivea* ascospores, among others, are extremely resistant to heat and are often responsible for the deterioration of fruits and derived products processed by heat (Kotzekidou 1997, Samapundo et al. 2018, Santos et al. 2018). Hatcher et al. (1979) showed that ascospores retain viability up to temperatures of 98°C.

Regarding the species *B. nivea*, recently Samapundo et al. (2018) studied the combined effect of heat treatment on the inactivation of their ascospores at different temperatures (range 85 to 95 °C) depending on the pH of the medium (range 4 to 6), finding D (decimal reduction time) values independent of pH and varying from 1.1-1.2 minutes at 90 °C, up to 15-16 minutes at 85 °C. Nguyen (2012) carried out an exhaustive review of the works on the factors that affect the heat resistance of the *Byssochlamys* ascospores. Distinguishing it from other fungi sensitive to heat treatments that can be destroyed by heating at 65 °C for 10 minutes (Houbraken et al. 2006, Splittstoesser et al. 1971, 1974), the ascospores of the species *Byssochlamys* are highly resistant to heat, which makes many industrial thermal processes inefficient. In practice, in general, the processes preferably used by the food industry

are relatively gentle to preserve the sensory and nutritional attributes of products (Henry & Heppell 2002, Polydera et al. 2003, Awuah et al. 2007); for example, for fruit juices temperatures of 89-90 °C for 12-14 seconds are used (Cartwright & Hocking 1984). Unfortunately, the ascospores of *Byssochlamys fulva* and *B. nivea* -common in grapes- cannot be effectively inactivated by these less severe treatments (Nguyen 2012). However, the Food and Agriculture Organization of the United Nations (FAO) has recommended a heating regime of approximately 100 °C for 60 seconds for fruit juices if there are likely to be *Byssochlamys* species (Bates et al. 2001).

In several studies, the heat resistance of *Byssochlamys* ascospores has been investigated using different methods and conditions. In general, heat resistance reports can be classified into two categories: resistance to various time-temperature combinations or thermal reduction times (D) and temperature resistance coefficients (z). Table II and Table III present the responses of the *B. fulva* and *B. nivea* ascospores by applying different heating treatments reported in the literature to products based on grapes and other fruits, while Table IV shows the typical values of D and z (Nguyen 2012).

B. fulva ascospores have greater thermal resistance than those of *B. nivea*; *B. fulva* presenting higher values of D and z than *B. nivea*. For *B. fulva* ascospores, typical values of D_{90} and z are 1-12 minutes (Bayne & Michener 1979) and 6-7 °C (King et al. 1969); while for *B. nivea* correspond D_{85} and z values of 0.6-1.2 minutes and 4.2-5.8 °C (Quintavalla & Spotti 1993) (Table IV).

By way of illustration, Figure 2 shows the (original) results obtained by King et al. (1969) for ascospores of *B. fulva*, coinciding with the aforementioned observations regarding the protective effect of the high concentration of sugars from concentrated grape juice on the decimal reduction time of ascospores, compared to the behavior of the reconstituted grape juice that it has fewer sugars. It can be noted that for thermal process temperatures of the order of 100 °C, the decimal reduction times are reduced to a few seconds.

Based on the analysis of the dataset presented, and fundamentally considering the FAO recommendations, the higher thermal resistance (and its D and z values) of the *B. fulva* ascospores compared to *B. nivea*, and the high acidity and low sugar content of the developed product, two possible thermal treatments for

Table II. Thermal resistance of ascospores of *Byssochlamys fulva* depending on the heating regime in products based on grapes and other fruits.

Heating regimen	Heating medium	Lethality*	Reference
87-88 °C ; 30 min	canned / bottled fruits	NL	Olliver & Smith (1933)
84-88 °C ; 30 min	fruit syrup	NL	Olliver & Rendle (1934)
85 °C ; 60-180 min	fruit juices	NL	Splittstoesser et al. (1974)
87.8 °C ; 81.4 min 92.2 °C ; 13.7 min	reconstituted grape juice (16 °Brix)	L	King et al. (1969)
86.7 °C ; 118 min 92.2 °C ; 6.8 min	concentrated grape juice (68 °Brix)	L	King et al. (1969)
up to 80 °C ; 60 min	homogenized grape juice	NL	Splittstoesser et al. (1971)
86 °C ; 53 min	grape juice	L	Michener & King (1974)

* Denotes the survival of the molds after heat treatment: NL: non-lethal, colonies are detected; L: lethal, no colonies detected.

the inactivation of habitual thermosensitive fungi (*B. fulva* and *B. nivea*) equivalent to $D_{90} = 1-12$ minutes (Bayne & Michener 1979) and $z = 6-7$ °C (King et al. 1969) were proposed:

- T1 heat treatment: after hot filling in sterile containers, keep the product in a pre-heated autoclave (121.1 °C, 20-32 lb/in²) for 5 minutes, to achieve the desired inactivation temperature of 100 °C throughout the product, and keep it for 1.3 to 27 seconds;
- T2 heat treatment: after hot filling in sterile containers, keep the product in a pre-heated autoclave (121.1 °C, 20-32 lb/in²) for 10 minutes, to achieve the desired inactivation temperature of 100 °C throughout the product, and keep it for 1.3 to 27 seconds.

For the two proposed heat treatment time scenarios, for comparative purposes, the simulation of conduction heat transfer in the process was performed, to estimate the time required for the center of the container (thermal center) to reach the temperature desired (Lespinard et al. 2012) at 100 °C, and hold for 1.3 to 27 seconds, as these are the recommended necessary conditions to ensure *Byssochlamys* ascospore inactivation (King et al. 1969, Hatcher et al. 1979, FAO 2018, Samapundo et al. 2018).

Simulation of the heat transfer during thermal treatment by mean of FEM models

Approach to the heat transfer problem

To solve the spatiotemporal differential equation that governs the thermal process, a transient analysis was carried out with the General Heat Transfer module of the COMSOL Multiphysics® 3.5a software, simplifying the problem based on two model proposals.

- A cylindrical axisymmetric two-dimensional domain, taking an average radius (R) between the radius r ($r = 36.75 \times 10^{-3}$ m) and a ($a = 32.58 \times 10^{-3}$ m), which refer to the circumscribed and inscribed circles, respectively (Figure 3a).
- A three-dimensional domain that by the symmetry of the system takes into account only one of the 6 equivalent parts that make up the hexagonal container (Figure 3b).

Governing equation of the transient state driving problem

For these models, the equation that governs the transfer of heat by conduction in a transient state in solid or high-viscosity foods described by the second Fourier's law was represented by the following partial differential Equation 1 (Bird et al. 2006, Lespinard et al. 2009):

$$\rho C_p \frac{\partial T}{\partial t} - \nabla \cdot k \nabla T = 0 \tag{1}$$

Table III. Thermal resistance of ascospores of *Byssochlamys nivea* depending on the heating regime in products based on grapes and other fruits.

Heating regimen	Heating medium	Lethality*	Reference
87.5 °C ; 10 min	strawberries heat processed	NL	Put & Kruiswijk (1964)
90-92 °C ; 10 min	strawberries heat processed	L	Put & Kruiswijk (1964)
85 °C ; 20 min	tomato paste	NL	Kotzekidou (1997)
75 °C ; 7 h	grape juice	L	Beuchat & Toledo (1977)

*Denotes the survival of the molds after heat treatment: NL: non-lethal, colonies are detected; L: lethal, no colonies detected.

where: ρ : density (kg/m^3); C_p : specific heat ($\text{kJ/kg } ^\circ\text{C}$); T : temperature ($^\circ\text{C}$); t : time (s); k : thermal conductivity ($\text{W/m } ^\circ\text{C}$).

Theoretical solution of the equation of non-stationary heat conduction

Considering the product simply represented as a cylindrical domain, *a priori* a simplified semi-analytical solution to the problem was assayed to estimate the required time to reach the desired temperature of $100\text{ }^\circ\text{C}$ in the center. The transient two-dimensional conduction problem was described by a “superposition” of two problems: the transient conduction in a plate and the transient conduction in a infinite cylinder (Bird et al. 2006, Welty et al. 2014).

For constant thermal properties of the domain evaluated at the initial temperature of the product ($98\text{ }^\circ\text{C}$), and using a typical heat transfer coefficient of $2000\text{ W/m}^2\text{-K}$ in the sterilizer (Kumar et al. 1990), the solution of the problem of heat transfer considering the first term of the series resulted in about 12-15 minutes to reach $100\text{ }^\circ\text{C}$ in the center. This result

was used to compare with the predictions of the simulation models.

Definition of the models 2D-axisymmetric and 3D and domains discretization

The proposed 2D domain was represented by geometry with axial symmetry considering all the materials that make up the product: glass container, tin twist-off lid, low-calorie grape jam, and headspace air (Figure 3a). This simplification of the model assuming axial symmetry, although it provides an approximate solution, allows reducing the number of mesh nodes, with the consequent decrease in the calculation time involved and the memory required for processing (Martínez & Rosenberger 2013). For the discretization of the domain, after having analyzed the convergence of results with different degrees of refinement of the automatic mesh, a mesh was selected containing 17376 Lagrangian triangular elements with 35184 degrees of freedom and a minimum element quality of 0.72.

Table IV. D and z values for ascospores of the species *Byssochlamys fulva* and *B. nivea* (Nguyen 2012).

Species	D and z values	Heating medium	Reference
<i>B. fulva</i>	$D_{85} = 26.18\text{--}59.78\text{ min}$	clarified apple juice	Sant’Ana et al. (2009)
	$D_{86} = 13\text{--}14\text{ min}$	grape juice	Michener & King (1974)
	$D_{87.8} = 4.8\text{--}11.3\text{ min}$	grape juice	King et al. (1969)
	$D_{90} = 1\text{--}12\text{ min}$	apple juice	Bayne & Michener (1979)
	$z = 7.1\text{ }^\circ\text{C}$	clarified apple juice	Sant’Ana et al. (2009)
	$z = 6\text{--}7\text{ }^\circ\text{C}$	grape juice	King et al. (1969)
	$z = 10\text{--}13.9\text{ }^\circ\text{C}$	grape juice (13 °Brix)	Hatcher et al. (1979)
<i>B. nivea</i>	$D_{75} = 60\text{ min}$	grape juice	Beuchat & Toledo (1977)
	$D_{80} = 6.6\text{--}5.7\text{ min}$	grape juice (17 °Brix)	Quintavalla & Spotti (1993)
	$D_{85} = 0.6\text{--}1.2\text{ min}$	grape juice (17 °Brix)	Quintavalla & Spotti (1993)
	$z = 4.2\text{--}5.8\text{ }^\circ\text{C}$	grape juice (17 °Brix)	Quintavalla & Spotti (1993)

The 3D domain was represented by a simplified spatial geometry with axial symmetry representative of 1/6 of the glass container containing the jam (Figure 3b). For the discretization of the 3D domain, an automatic mesh of 18248 Langrangian tetrahedral elements was used.

In both cases, this mesh density was determined by analyzing the convergence of results.

Initial and boundary conditions of the models

As initial conditions for the entire 2D axial symmetric domain, a uniform temperature T_0 (Equation 2) was considered, which corresponded to the temperature of the product and the container at the time of hot filling ($T_0 = 98 \text{ }^\circ\text{C}$):

$$T(r, z, 0) = T_0(r, z) \text{ for } t = 0; 0 \leq r \leq R; 0 \leq z \leq H \quad (2)$$

where: R: radius of the domain (m); H: height of the domain (m).

For the 3D domain case, the initial conditions were also uniform temperature (Equation 3) $T_0 = 98 \text{ }^\circ\text{C}$ throughout the domain:

$$T(x, y, z) = T_0(x, y, z) \text{ for } t = 0; 0 \leq x \leq R; 0 \leq y \leq R, 0 \leq z \leq H \quad (3)$$

Meanwhile, as boundary conditions for both domains, an outer wall temperature T_w (Equations 4 and 5) equal to the temperature of the steam in the autoclave ($121.1 \text{ }^\circ\text{C}$) was imposed:

$$\text{Axial symmetric 2D model: } T = T_w \text{ for } r = R; 0 \leq z \leq H \quad (4)$$

$$\text{3D model: } T = T_w \text{ for } x = R; y = R; 0 \leq z \leq H \quad (5)$$

where: T_w : temperature of the external wall of the container ($^\circ\text{C}$) (temperature of the steam in the autoclave), which was considered constant.

In both domains for the other contours, insulation/symmetry conditions were assumed.

Thermophysical properties for the definition of domains

In the definition of the thermophysical parameters (density, thermal conductivity, specific heat) of the sub-domain representing the low-calorie jam, that was necessary for solving the transient heat transfer problem, isotropic materials with variable properties with temperature were considered. These properties were calculated from the proximal composition of the product determined experimentally (Table I) and from the correlations shown in Table V, applicable to food in general to determine the properties of the main components (carbohydrates, water, ash, proteins, etc.) (Choi & Okos 1986, Ibarz-Ribas & Barbosa-Cánovas 2005).

The thermal properties were averaged within the jam subdomain by applying the expressions recommended by Choi & Okos (1986), and Ibarz-Ribas & Barbosa-Cánovas (2005). The mean

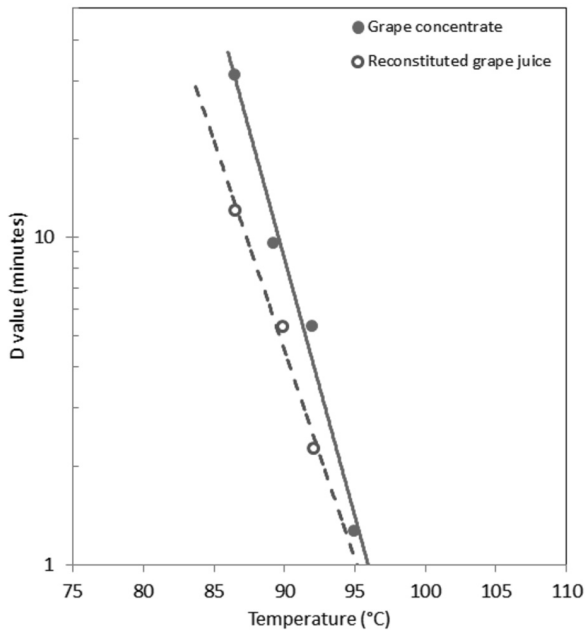

Figure 2. D values for *B. fulva* ascospores in concentrated and reconstituted grape juices (King et al. 1969).

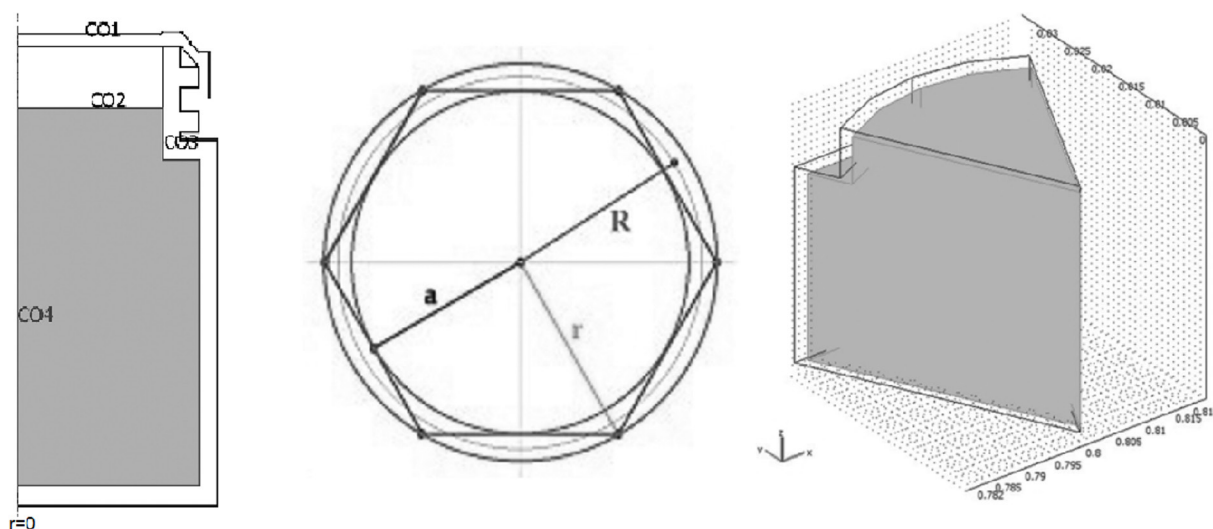

Figure 3. (a) 2D domain with axial symmetry representing the hexagonal container containing the low-calorie grape jam, accompanied by geometric detail of the radius (r) of the circumference that inscribes the vertical projection of the hexagonal container and the radius (a) corresponding to the inner circumference tangent to the faceted faces of the container; (b) Representative 3D domain of 1/6 of the hexagonal container containing the low-calorie grape jam.

density of the jam was calculated considering the densities of the components present in the proximal composition, and their corresponding mass fractions (Choi & Okos 1986). While the mean thermal conductivity and heat capacity of the product were both estimated considering the volumetric mean of the thermal conductivities and heat capacities of water, proteins, carbohydrates, and ashes (Ibarz-Ribas & Barbosa-Cánovas 2005).

The correlations that describe the physical properties of the jam as a function of temperature, were loaded in the models as Subdomain Expressions. To define the physical parameters of the rest of the materials (container glass, tin lid, and headspace air) constant properties were used according to the data presented in Table VI that are reported in the bibliography.

Resolution of the thermal problem

Non-stationary models were solved using Solver Direct UMFPAK, with a time scaling by BDF method, a tolerance of 0.001, and a step size of 10 s up to a total thermal process time of

900 s. The resolution involved 96.135 s to obtain the solution of the 2D model on a Toshiba Intel Pentium Dual CPU T3400 2.17 GHz 64-bit and 151.751 s model for the 3D model resolved on a Bangho Mov Intel Core i3-2350M CPU 2.30 GHz 32-bit equipment.

Prediction of the temporal evolution of the temperature during thermal treatment

Figure 4 shows the predictions of the temperature in the entire 2D (a) y 3D (b) domains at two process times (5 and 9 minutes). Meanwhile, Figure 5 shows the time evolution of the predicted temperature in the thermal center of the container for domains 2D (a) and 3D (b). In these heating curves at the point furthest from the outside of the system, the initial thermal inertia typical of these viscous products can be seen, following what was observed by Lespinard et al. (2009).

As a result of this analysis, as can be seen in Figure 5, the temperature predictions provided by the 2D and 3D models allowed us to estimate that between 500 and 550 seconds (respectively)

Table V. Correlations for the estimation of thermophysical properties of the majority components of foods.

Property	Component	Correlation
Density ρ (kg m ⁻³)	carbohydrates	$1.5991 \times 10^3 - 0.31046T$
	proteins	$1.3299 \times 10^3 - 0.5184T$
	ash	$2.4238 \times 10^3 - 0.28063T$
	water	$997.18 + 3.14439 \times 10^3 T - 3.7574 \times 10^3 T^2$
Thermal conductivity k (W m ⁻¹ K ⁻¹)	carbohydrates	$0.22141 + 1.3874 \times 10^3 T - 4.3312 \times 10^{-6} T^2$
	proteins	$0.17881 + 1.1958 \times 10^3 T - 2.7178 \times 10^{-6} T^2$
	ash	$0.32962 + 1.4011 \times 10^3 T - 2.9069 \times 10^{-6} T^2$
	water	$0.57109 + 1.7625 \times 10^3 T - 6.7036 \times 10^{-6} T^2$
Specific heat C_p (kJ kg ⁻¹ K ⁻¹)	carbohydrates	$1.5488 + 1.9625 \times 10^3 T - 5.9399 \times 10^{-6} T^2$
	proteins	$2.0082 + 1.2089 \times 10^3 T - 1.3129 \times 10^{-6} T^2$
	ash	$1.0926 + 1.8896 \times 10^3 T - 3.6817 \times 10^{-6} T^2$
	water	$4.1762 - 9.0864 \times 10^{-5} T - 5.4731 \times 10^{-6} T^2$

Table VI. Material properties which used in the definition of the subdomains considered in the models.

Material	Density ρ (kg m ⁻³)	Thermal conductivity k (W m ⁻¹ K ⁻¹)	Specific heat C_p (J kg ⁻¹ K ⁻¹)	Reference
tin	7265	66.8	210	American Elements (2016)
glass	2243	1.125	963	Lespinard et al. (2012)
air	1.184	0.02551	1007	Çengel & Cimbala (2006)

of treatment, the desired temperature is reached in the thermal center of 100 °C. These results, predicted using thermal properties varying with temperature, yield a more realistic description of the thermic problem, allowing also to reduce the estimated warming time in the simplified analytic approach.

Considering that once the proposed microbiological inactivation temperature has been reached, it is necessary to keep the product in these conditions for 1.3 to 27 seconds, based on the observed results, it was established that the containers should be kept in the autoclave at 121.1 °C for not less than 10 minutes to achieve the effectiveness of the thermal process. This numerical analysis strengthens the selection of

one of the proposed treatment times for product sterilization ($T_2 = 10$ minutes).

However, in literature has been reported that due to the high thermal inertia of jams (characteristic of this type of product and container), the temperature of the thermal center continues to rise for a long period even during the cooling stage (Lespinard et al. 2009, Martínez & Rosenberger 2014). It has been observed that the greatest microbial inactivation (accumulated lethality) occurs during the cooling stage (contrary to what occurs in canned products). This inertia could be beneficial for the destruction of microorganisms, but could degrade the organoleptic quality of the products. Based on these observations, it

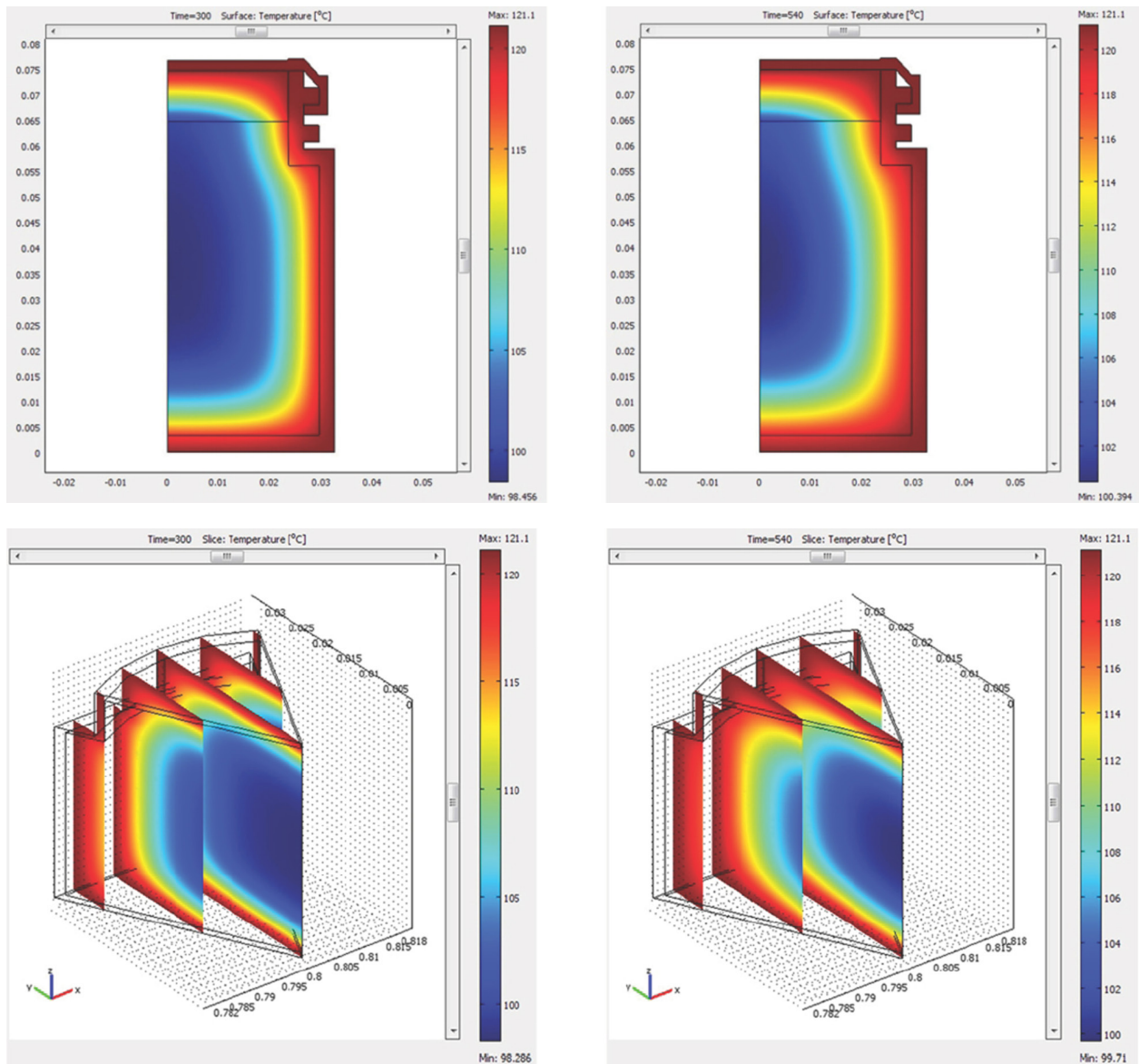

Figure 4. Temperature profiles in each of the domains, predicted by 2D axial symmetry (a) and 3D (b) models at 5 and 9 minutes of thermal treatment.

could be thought that the shorter treatment ($T_1 = 5$ minutes), given the thermal inertia, could achieve the objective of maintaining the thermal center at $100\text{ }^\circ\text{C}$ for 27 seconds required for microbiological inactivation of the product. This must be verified by appropriate microbiological analysis. From another point of view, a shorter treatment would allow to conserve more the attributes of quality.

Additionally, the model was rescaled doubling the size of the container (maintaining the spatial relationships), and the problem of heat transfer was solved again for the same initial and contour conditions, to have an evaluation of whether the designed treatments (T_1 and T_2) would cover requirement planned for the sterilization. From this analysis, it was estimated that the time required for the thermal center to reach and maintain the desired temperature

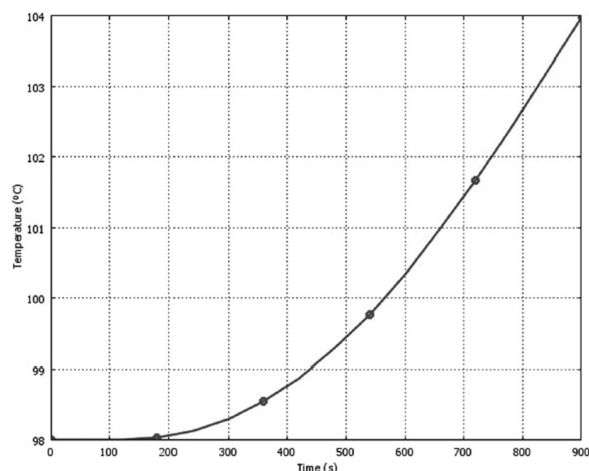
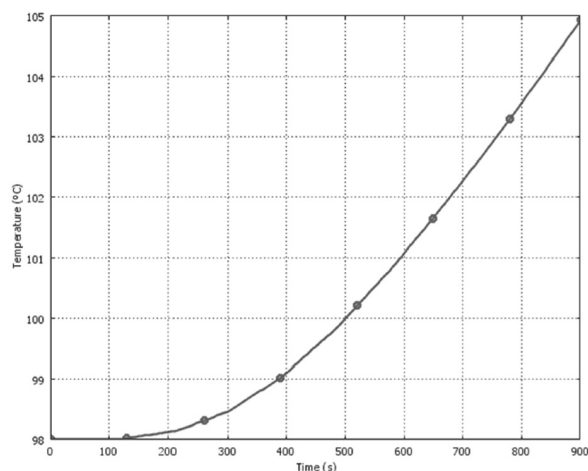

Figure 5. Evolution of the predicted temperature in the thermal center of the container for both domains, 2D (a) and 3D (b).

of 100 °C for 27 seconds would be practically double (1070 seconds) than that required in the case of the container used experimentally in this work. With these results, neither of the two treatments would be effective, which highlights the modeling of the process due to its versatility as a prediction tool.

In any case, it is necessary to validate these results through ineluctable microbiological analyzes, which were carried out for jams sterilized by the treatment selected from the numerical model (T2), and also for the shorter treatment (T1) to establish, on this analytical basis, the effectiveness of the proposed thermal treatment (s).

Results of microbiological analysis of the thermally treated samples

To carry out the sterilization process under these selected conditions, the freshly made and hot-packed (98 °C) jams in the thermostatically sterile jars were immediately taken to a vertical batch-type autoclave previously preheated from room temperature until sufficient steam production (around 100 °C). The containers were placed in the basket and the equipment was closed, reaching a temperature of 121.1 °C

and a pressure of 20-32 lb/in² in approximately 120 s. The products were kept in the sterilizing equipment under these conditions during the preset heating times (T1 and T2). The products were then subjected to an initial cooling stage, eliminating the overpressure of the autoclave, which was then completed by immersing the containers in a thermostatic bath at 50 °C to avoid thermal shock due to direct contact with the environmental conditions that could cause the breakage of the glass (Lespinard et al. 2009).

Immediately after sterilization performed by the two selected heat treatments (T1 and T2), low-calorie Stevia-based grape jams were microbiologically evaluated to verify the efficacy of the process. Likewise, the same analysis was carried out on samples of the product once it was opened and stored in a refrigerator (2 to 8 °C) for more than 5 months, to have a brief estimate of its useful life under these conditions (simulating consumption of a potential consumer of the product).

In the plates used in the microbiological analysis of the jams sterilized by the two selected heat treatments (T1 and T2), growth was observed that corresponded mainly with molds, filamentous multicellular fungi, easily

distinguishable by their cottony or velvety colonial morphology (Figure 6). Yeasts also generally grow in the form of aggregates of independent cells, which can be of various forms, usually globose. When grown in solid media they form colonies similar to bacterial colonies. The importance of the determination of these microorganisms in food lies in the fact that they are the main ones involved in their deterioration and decomposition, and they can also produce toxic substances called mycotoxins (ANMAT 2014).

As can be seen in Table VII, the values of the samples analyzed immediately after the thermal treatments, regarding the presence of molds and yeasts, resulted well below the maximum tolerance reference value required by the Argentine Food Code (CAA 2018), which establishes a maximum of 1000 CFU/g for ready-to-eat dietary foods (in this case, modified in their glucidic composition). This shows that

in both cases the processing and sterilization conditions can be considered adequate.

Regarding the samples opened after sterilization which were kept for 5 months under refrigeration, it was observed that the jam subjected to the T1 heat treatment presented a higher amount of CFU per g of molds and yeasts, exceeding 4 times the range allowed by the CAA (2018). This result would give rise to thinking about a shorter useful life of the product once it is opened and kept in the refrigerator when the shorter heat treatment (T1) is applied. However, additional microbiological analyzes performed on samples of jam sterilized by both heat treatments that were kept in their sealed container at room temperature in a dry place (shelf storage) for more than 5 months, met the CAA requirements by presenting less than 1000 CFU/g. These results could be interesting to have a preliminary estimate of the useful life of the product.

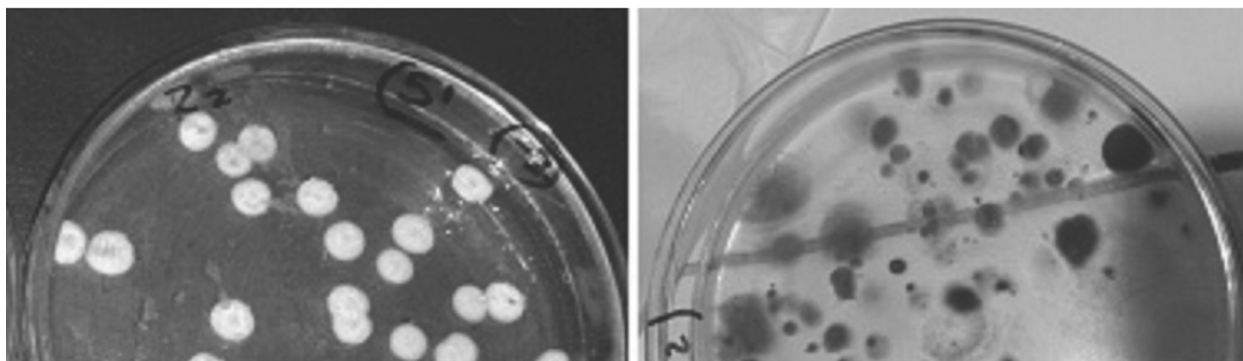

Figure 6. Images of microbiological cultures developed in samples sterilized by both heat treatments.

Table VII. Microbiological count in low-calorie grape jams.

Thermal treatment (T=100 °C)	Parameter	Analysis data		Reference value
		Initial ¹	> 5 months ²	
T1 (5 min)	Molds and yeasts (CFU*, g)	<10	4745	Maximum 1 × 10 ³
T2 (10 min)		<10	220	

*CFU (colony forming units): ¹Immediately after sterilizing the product; ²Once the container of the sterilized product has been opened, after 5 months of refrigerator storage.

CONCLUSIONS

Adequate thermal treatments were analyzed and defined for sterilization of a low-calorie grape jam obtained using fruits reduced in their natural carbohydrates by an optimized pretreatment, and Stevia natural sweetener as a replacement for sucrose. The selection of the appropriated thermal processes was founded on the physicochemical characteristics and proximal composition experimentally determined for jam (39.26 ± 0.63 °Brix; $\text{pH } 3.63 \pm 0.04$), the analysis of the potential microorganisms (fungus) that could be developed in the product, the determination of thermo-physical properties of the jam, the analysis of recommended combinations of time-temperature for thermal treatments to inhibit microorganisms, the development of numerical models to predict the temperature profiles during thermal treatment, and the final microbiological analysis. As a result of this study, two heat treatments were proposed to inhibit the fungus *B. fulva* and *B. nivea* (usual in grapes). The autoclave sterilization processes (121.1 °C; $20\text{-}32$ lb/in²) were defined by the combinations of time and temperature, T1: 100 °C - 5 minutes; T2: 100 °C - 10 minutes, to apply and maintain the desired temperature of 100 °C in the entire product for 1.3 to 27 seconds. Both treatments of sterilization were considered adequate and were validated by microbiological analysis.

REFERENCES

- AMERICAN ELEMENTS. 2021. The Advanced Material Manufacturer^á. Tin Properties, CAS# 7440-31-5, <https://www.americanelements.com/sn.html>.
- ANMAT. 2014. Asociación Nacional de Medicamentos, Alimentos y Tecnología Médica. Análisis Microbiológico de los Alimentos. Metodología Analítica Oficial. Microorganismos Indicadores. Vol. III. Buenos Aires: Ministerio de Salud, Presidencia de la Nación, Argentina, 153 p.
- ANSORENA MR & SALVADORI VO. 2011. Optimization of thermal processing of canned mussels. *Food Sci Technol Int* 17: 449-458.
- AOAC. 1980. Official Methods of Analysis of AOAC (Association of Official Analytical Chemists) Washington D.C.: AOAC, Method 923.03.
- AOAC. 2000. Official Methods of Analysis of AOAC (Association of Official Analytical Chemists) Washington D.C.: AOAC, Method 920.152.
- ATHAYDE DE SOUZA PB, FIOROTTI POLTRONIERI K & LUERA PEÑA WE. 2012. Estudio de resistência térmica de *Byssochlamys nivea* em suco de abacaxi e mamão. In: Anais de Trabalhos Completos de XVI Encontro Latino Americano de Iniciação Científica e XII Encontro Latino Americano de Pós-Graduação. Vale do Paraíba, Brasil: Universidade do Vale do Paraíba.
- AUGUSTO PED, PINHEIRO TF & CRISTIANINI M. 2010. Using Computational Fluid-Dynamics (CFD) for the evaluation of beer pasteurization: effect of orientation of cans. *Food Sci Technol* 30: 980-986.
- AWUAH GB, RAMASWAMY HS & ECONOMIDES A. 2007. Thermal processing and quality: principles and overview. *Chem Eng Process* 46: 584-602.
- BARRANTES SALAS A. 2009. Desarrollo de una mermelada sin adición de azúcar empleando gomas que produzcan geles similares a la pectina y evaluación de los costos de materia prima. Thesis, Facultad de Ciencias Agroalimentarias, UNCR, San José de Costa Rica.
- BATES RP, MORRIS JR & CRANDALL PG. 2001. Principles and Practices of Small- and Medium-Scale Fruit Juice Processing. Rome: FAO, 221 p.
- BAYNE HG & MICHENER HD. 1979. Heat resistance of *Byssochlamys* ascospores. *Appl Environ* 37: 449-453.
- BEUCHAT LR & RICE SL. 1979. *Byssochlamys* spp. and their importance in processed fruits. *Adv Food Res* 25: 237-288.
- BEUCHAT LR & TOLEDO RT. 1977. Behavior of *Byssochlamys nivea* ascospores in fruit syrups. *Trans Brit Mycol Soc* 68: 65-71.
- BIRD RB, STEWART WY & LIGHTFOOT EN. 2006. Transport Phenomena. New Jersey: J Wiley & Sons, 928 p.
- BLANCO ANESTO J. 2002. Consumir azúcar con moderación. *Rev Cubana Aliment Nutr* 16: 142-145.
- CAA. 2018. Código Alimentario Argentino (online). Capítulo XVII: Alimentos de Régimen o Dietéticos. Buenos Aires: ANMAT. Ministerio de Salud. Presidencia de la Nación, Argentina.

- CAMACHO A, GILES M, ORTEGÓN A, PALAO M, SERRANO B & VELÁZQUEZO. 2009. Técnicas para el Análisis Microbiológico de Alimentos. México: Facultad de Química UNAM.
- CARTWRIGHT P & HOCKING AD. 1984. *Byssochlamys* in fruit juices. Food Tech. Australia 36: 210-211.
- ÇENGEL YA & CIMBALA JM. 2006. Mecánica de Fluidos: Fundamentos y Aplicaciones. México: McGraw-Hill, 942 p.
- CERESER ND, COSTA FMR, ROSSI JÚNIOR OD, SILVA DARD & SPEROTTO VDR. 2008. Botulismo de origem alimentar. Cienc Rural 38: 280-287.
- CHOI Y & OKOS MR. 1986. Effects of temperature and composition on the thermal properties of foods. In: Maguer L and Jelen P (Eds) Food Engineering and Process Applications, Vol. 1, Transport Phenomenon. New York: Elsevier, p. 93-101.
- DA ROCHA FERREIRA EHR, MASSON LMP, ROSENTHAL A, SOUZA ML, TASHIMA L & MASSAGUER PR. 2011. Thermoresistance of filamentous fungi isolated from aseptically packaged fruit nectars. Braz J Food Technol 14: 164-171.
- FAO. 2009. CODEX ALIMENTARIUS (online). Standard for jams, jellies and marmalades, CXS 296-2009 (Adopted in 2009. Amended in 2017, 2020), 10 p.
- FDA. 2001. Bacteriological Analytical Manual (online). 8th Edition, Revision A, 1998, White Oak: FDA.
- GARG A. 2019. Processing and mathematical modeling of heat & mass transfer across layered food structures. Doctoral dissertation, ETH, Zurich.
- GARRO MENA F. 2007. Desarrollo de un software para el cálculo de la letalidad en procesos de esterilización de alimentos. Bachelor's thesis, Escuela de Ingeniería Química, Facultad de Ingeniería, UNCR, San José de Costa Rica.
- GILLESPIE TG & THORPE RH. 1962. Survey of *Byssochlamys fulva* ascospore infection on strawberries for canning. Tech. Memo. 44, Fruit and Vegetable Canning and Quick Freezing Campden, England: Res Assoc.
- GÓMEZ-SÁNCHEZ AI. 2007. Microorganismos de importancia en el tratamiento térmico de alimentos ácidos y de alta acidez. TSIA 1: 24-32.
- HATCHER WS, WEIHE JL, MURDOCK DI, FOLINAZZO JF, HILL EC & ALBRIGO LG. 1979. Growth requirements and thermal resistance of fungi belonging to the genus *Byssochlamys*. J Food Sci 44: 118-122.
- HENRY CJK & HEPPELL N. 2002. Nutritional losses and gains during processing: future problems and issues. Proc Nutr Soc 61: 145-148.
- HOUBRAKEN J, SAMSON RA & FRISVAD JC. 2006. *Byssochlamys*: significance of heat resistance and mycotoxin production. In: Hocking AD, Pitt JI, Samson RA, Thrane U (Eds). Adv Exp Med Biol, vol. 571. New York: Springer, p. 211-224.
- HUACUZ ES, ALVARADO DR, BRAVO EN, CELAYA MD & PAVÍA SPF. 2013. Técnicas de purificación de aislamientos de *Phytophthora* contaminados por bacterias. Biológicas 12: 61-64.
- IAÑEZ E. 2005. TEMA 13.- Acción de los agentes físicos sobre las bacterias. Sitio web Microbiología General, Licenciatura de Biología, Universidad de Granada. https://www.ugr.es/~eianez/Microbiologia/13agfisicos.htm#_Toc59451641.
- IBARZ-RIVAS A & BARBOSA-CANOVAS GV. 2005. Operaciones unitarias en la ingeniería de alimentos, edición 2005, Madrid: Mundi-prensa, 868 p.
- ICMSF. 2005. International Commission of Microbiological Specifications for Food. Microbial Ecology of Foods Commodities. Volume 1: Factors Affecting Life and Death of Microorganisms. New York: Kluwer Academic/Plenum Publishers, 763 p.
- IGUAL M, GARCÍA-MARTÍNEZ E, CAMACHO MM & MARTÍNEZ-NAVARRETE N. 2015. Stability of micronutrients and phytochemicals of grapefruit jam as affected by the obtention process. Food Sci Technol Int 22: 203-212.
- INTA. 2018a. Elaboración de Conservas Caseras (online). Buenos Aires: Programa PROCADIS, Secretaría de Agroindustria, Ministerio de Producción y Trabajo, Presidencia de la Nación, Argentina, 18 p.
- INTA. 2018b. Manual de Conservas (online). Agencia de Extensión Rural Juan José Castelli: INTA. (Instituto Nacional de Tecnología Agropecuaria), Ministerio de Agroindustria, Presidencia de la Nación, Argentina, 49 p.
- JAY JM. 1992. Food preservation with chemicals. In: Modern Food Microbiology. Netherlands: Springer, p. 251-289.
- KARPIŃSKA-TYMOSZCZYK M, DRASZANOWSKA A, DANOWSKA-OZIEWICZ M & KURP L. 2020. The effect of low-temperature thermal processing on the quality of chicken breast fillets. Food Sci Technol Int 26: 563-573.
- KAUSHIK N, RAO PS & MISHRA HN. 2018. Comparative analysis of thermal-assisted high pressure and thermally processed mango pulp: Influence of processing, packaging, and storage. Food Sci Technol Int 24: 15-34.
- KING AD, MICHENER HD & ITO KA. 1969. Control of *Byssochlamys* and related heat-resistant fungi in grape products. Appl Microbiol 18: 166-173.

- KING AD & WHITEHAND LC. 1990. Alteration of *Thalaromyces flavus* heat resistance by growth conditions and heating medium composition. *J Food Sci* 55: 830-832.
- KOTZEKIDOU P. 1997. Heat resistance of *Byssochlamys nivea*, *Byssochlamys fulva* and *Neosartorya fischeri* isolated from canned tomato paste. *J Food Sci* 62: 410-412.
- KUMAR A, BHATTACHARYA M & BLAYLOCK J. 1990. Numerical simulation of natural convection heating of canned thick viscous liquid food products. *J Food Sci* 55: 1403-1411.
- LABORDE MB. 2019. Mermeladas de bajo contenido calórico a partir de uva osmodeshidratada: efecto de la sustitución de azúcares naturales por steviósidos y maltodextrina en las propiedades físicas, antioxidantes y atributos sensoriales. Doctoral dissertation, Doctoral Thesis. Universidad Nacional del Centro de la Provincia de Buenos Aires (UNICEN), Olavarría, Argentina.
- LABORDE MB, BARRETO GP & PAGANO AM. 2018. Ultrasound-assisted dehydration process applied to *Red Globe* grapes for producing low-calorie raisins. *Am J Food Technol* 6: 209-214.
- LESPINARD AR, BAMBICHA RR, AGNELLI ME & MASCHERONI RH. 2009. Modelado de la transferencia de calor y variación de índices de calidad en mermeladas durante el proceso de pasteurización. *Mec comput* 28: 3067-3077.
- LESPINARD AR, BAMBICHA RR & MASCHERONI RH. 2012. Quality parameters assessment in kiwi jam during pasteurization. Modelling and optimization of the thermal process. *Food Bioprod Process* 90: 799-808.
- MANRIQUE G. 2020. Capítulo 7. Examen de los métodos de análisis. Facultad de Ingeniería, Tandil: Universidad Nacional del Centro de la Provincia de Buenos Aires, p. 107-231.
- MARTÍNEZ AM & ROSENBERGER MR. 2013. Modelado numérico de pasteurización artesanal de leche y jugos naturales. *Mec Comput* 32: 2485-2501.
- MARTÍNEZ AM & ROSENBERGER MR. 2014. Simulación numérica del proceso de pasteurización artesanal de leche. *Mec Comput* 33: 3361-3377.
- MICHENER HD & KING AD. 1974. Preparation of free heat-resistant ascospores from *Byssochlamys asci*. *App Environ* 27: 671-673.
- NGUYEN AL. 2012. Contribution of intrinsic factors to heat resistance of ascospores of *Byssochlamys*. Doctoral dissertation, PhD Thesis. The University of New South Wales, Australia.
- NMX-F-436-SCFI. 2011. Norma Mexicana. Industria Azucarera y Alcoholera. Determinación de grados brix en jugos de especies vegetales productoras de azúcar y materiales azucarados - Método del Refractómetro. México: Secretaría de Economía, 8 p.
- ODLAUG TE, PFLUG IJ & KAUTTER DA. 1978. Heat resistance of *Clostridium botulinum* type B spores grown from isolates from commercially canned mushrooms. *J Food Prot* 41: 351-353.
- OLLIVER M & RENDLE T. 1934. A new problem in fruit preservation. *J Soc Chem Ind* 53: 166-172.
- OLLIVER M & SMITH G. 1933. *Byssochlamys fulva* sp. nov. *J. Bot.(London)* 71: 196-197.
- PITT JI & HOCKING AD. 1997. Methods for isolation, enumeration and identification. In: *Fungi and food spoilage*, Boston: Springer, p. 21-57.
- POLYDERA AC, STOFOROS NG & TAOUKIS PS. 2003. Comparative shelf life study and vitamin C loss kinetics in pasteurised and high pressure processed reconstituted orange juice. *J Food Eng* 60: 21-29.
- PUT HMC & KRUISWIJK JT. 1964. Disintegration and organoleptic deterioration of processed strawberries caused by the mould *Byssochlamys nivea*. *J Appl Microbiol* 27: 53-58.
- QUEVEDO-PRECIADO KL, VILLEGAS-OCHOA MA, GONZÁLEZ-RÍOS H & RODRÍGUEZ-FÉLIX A. 2005. Calidad de nopal verdura mínimamente procesado. Efecto de temperatura e inhibidores del oscurecimiento. *Rev Fitotec Mex* 28: 261-270.
- QUINTAVALLA S & SPOTTI E. 1993. Heat resistance of *Talaromyces flavus*, *Neosartorya fischeri* and *Byssochlamys nivea* isolated from fresh fruits. *MAN* 11: 335-341.
- SALOMÃO BDCM. 2002. Isolamento, identificação e estudo da resistência térmica de fungos filamentosos termorresistentes em produtos de frutas. Master's thesis, Centro Tecnológico Universidade Federal de Santa Catarina, Florianópolis, Brasil.
- SAMAPUNDO S, VROMAN A, EECKHOUT M & DEVLIEGHIERE F. 2018. Effect of heat treatment intensity on the survival, activation and subsequent outgrowth of *Byssochlamys nivea* ascospores. *LWT* 93: 599-605.
- SANT'ANA A, ROSENTHAL A & MASSAGUER PR. 2009. Heat resistance and the effects of continuous pasteurization on the inactivation of *Byssochlamys fulva* ascospores in clarified apple juice. *J Appl Microbiol* 107: 197-209.
- SANTOS JL, SAMAPUNDO S, GÜLAY SM, VAN IMPE J, SANT'ANA AS & DEVLIEGHIERE F. 2018. Inter-and intra-species variability in heat resistance and the effect of heat treatment

intensity on subsequent growth of *Byssochlamys fulva* and *Byssochlamys nivea*. *Int J Food Microbiol* 279: 80-87.

SCHMITT HP. 1966. Commercial sterility in canned foods, its meaning and determination. *Assoc Food Drug Off US Q Bull* 30: 141-151.

SENCAMER. 1979. Norma Venezolana COVENIN 1315:1979. Alimentos. Determinación de pH (acidez iónica). Comisión Venezolana de Normas Industriales. Caracas: FONDONORMA, 7 p.

SILVA FVM. 2015. Inactivation of *Byssochlamys nivea* ascospores in strawberry puree by high pressure, power ultrasound and thermal processing. *Int J Food Microbiol* 214: 129-136.

SINGH A, SINGH AP & RAMASWAMY HS. 2015. Computational techniques used in heat transfer studies on canned liquid-particulate mixtures. *Trends Food Sci Technol* 43: 83-103.

SPLITTSTOESSER DF. 1996. Microbiology of fruit products. In: Somogyi LP, Ramaswamy HS and Hui IH (Eds). *Processing Fruits: Science and Technology. Biology. Principles and Applications*. Lancaster, PA: Technomic Publishing Co., p. 261-292.

SPLITTSTOESSER DF, KUSS FR, HARRISON W & PREST DB. 1971. Incidence of heatresistant molds in eastern orchards and vineyards. *Appl Microbiol* 21: 335-337.

SPLITTSTOESSER F, EINSET A, WILKISON M & PREZIOSE J. 1974. Effect of food ingredients on the heat resistance of *Byssochlamys fulva* ascospores. In: *Proceedings of the Fourth International Congress of Food Science and Technology III*, vol. 3. Madrid: Instituto Nacional de Ciencia y Tecnología de Alimentos, Consejo Superior de Investigaciones Científicas, p. 79-85.

STUMBO CR. 1973. Factors influencing thermal resistance of bacteria. In: *Thermobacteriology in Food Processing*. New York: Academic Press, p. 112-118.

TORNESE M, ROSSI ML, COCA F, CRICELLI C & TRONCOSO A. 2008. Epidemiología y factores de riesgo asociados al botulismo de los alimentos y al botulismo infantil: ¿Dónde y cuándo? *Rev Chil Infect* 25: 22-27.

WANG L, DENG L, LI H, PENG J, HE C & XU J. 2017. Optimization of sterilization process of retort pouch tofu cake based on CFD numerical simulation. *Trans Chin Soc Agric Eng* 33: 298-306.

WELTY JR, WICKS CE, WILSON RE, RORRER GL. 2014. *Fundamentals of Momentum, Heat, and Mass Transfer*. 6th Edition, Chichister: J Wiley & Sons, Inc., 768 p.

How to cite

LABORDE MB & PAGANO AM. 2022. Analysis and numerical simulation of the sterilization of low-calorie grape jam. *An Acad Bras Cienc* 94: e20200584. DOI 10.1590/0001-376520220200584.

Manuscript received on April 19, 2020; accepted for publication on May 25, 2021

MARIANA B. LABORDE^{1,2}

<https://orcid.org/0000-0002-4854-3253>

ANA MARÍA PAGANO²

<https://orcid.org/0000-0001-7926-8269>

¹Consejo Nacional de Investigaciones Científicas y Técnicas (CONICET), Godoy Cruz 2290, C1425FQD Buenos Aires, Argentina

²Universidad Nacional del Centro de la Provincia de Buenos Aires (UNICEN), Facultad de Ingeniería, Departamento de Ingeniería Química y Tecnología de los Alimentos, Núcleo de Investigación Tecnologías de Semillas y Alimentos (TECSE), Av. del Valle 5737, B7400JWI Olavarría, Buenos Aires, Argentina

Correspondence to: **Ana María Pagano**

E-mail: anamariapagano@gmail.com,
apagano@fio.unicen.edu.ar

Author contributions

Mariana B. Laborde: Investigation, Planning of the study and experimental design, Experimental work, Data curation, Writing – original draft. Ana M. Pagano: Conceptualization, Methodology, Investigation, Planning of the study and experimental design, Conduction of the experiments. Writing – review & editing.

