

Article – Human and Animal Health

Activation of T-cells and Activity of Macrophages among Smokers with Leptospirosis: a Synergistic Dynamics in the Impairment of Human Immune System

Derick Erl Perida Sumalapao^{1*}
https://orcid.org/0000-0003-0361-8853

Jenny Carmina Gan So²
https://orcid.org/0000-0003-3793-4678

Angelyn Relucio Lao²
https://orcid.org/0000-0003-3028-9610

Nina Gonzales Gloriani³
https://orcid.org/0000-0001-9275-5758

Athena Acain Adriano²
https://orcid.org/0000-0002-9143-4554

¹University of the Philippines Manila, College of Public Health, Department of Epidemiology and Biostatistics, Manila, Philippines; ²De La Salle University, College of Science, Department of Mathematics and Statistics, Manila, Philippines; ³St. Luke's Medical Center, Institute of Pathology, Clinical Microbiology Section, Quezon City, Philippines.

Editor-in-Chief: Paulo Vitor Farago
Associate Editor: Paulo Vitor Farago

Received: 12-Mar-2022; Accepted: 24-Mar-2023.

*Correspondence: dpsumalapao1@up.edu.ph; Tel.: +6325247118 (D.S.)

HIGHLIGHTS

- Rate capacities of immune cell responses were computed using ordinary differential equations.
- Macrophages were predominant in the synergistic immune response to smoking and leptospirosis.
- *Leptospira* infection in human immune cells is dose-dependent.
- *Leptospira* infection is more rapid in smoking-impaired than the normal cells.

Abstract: Continuous heavy rains along with poor road construction and sewage system had resulted in the frequent occurrence of floods in many areas of the Philippines. As a consequence, leptospirosis remains an infectious disease endemic in the Philippines with numerous cases reported as aftermaths of typhoons especially after heavy flooding. Leptospirosis is known for its invasiveness in penetrating mucous membranes and abraded skin, in inducing macrophage response activity, and in activating T-cell proliferation. Chronic exposure to tobacco smoking weakens the immune system by reducing macrophage phagocytic activity and conferring T-cell insensitivity. In this study, a system of ordinary differential equations was developed to describe the synergy of leptospirosis and smoking in the impairment of immune system. The rate capacities of macrophages and T-cells in response to both smoking and leptospirosis were calculated. In the disease-free model, population of macrophages remains larger when compared with T-cells, and this predominance persists in the synergistic immune response to both smoking and leptospirosis. *Leptospira* infection in human immune cells is dose-dependent, and is more rapid in smoking-impaired than the normal cells. Findings of the study on these parameter estimates characterize the functions of macrophage and T-cell populations,

although further molecular studies are warranted, which are necessary to address the inadequacy of antibiotic therapy in advanced and severe leptospirosis cases.

Keywords: leptospirosis; macrophages; immune system; ordinary differential equations; tobacco smoking.

INTRODUCTION

An immune system becomes susceptible to different infections once persistently exposed to tobacco smoke [1]. Due to the poisonous, toxic, carcinogenic, and mutagenic substances found in tobacco smoke [2], chronic exposure to smoking suppresses human immune response by impairing the functions of macrophages and T-cells, with macrophages severely affected compared with T-cells [3,4]. Higher frequency of tobacco smoking exposure and higher smoking rates imply more reduced macrophage phagocytic function and diminished T-cell sensitivity [5,6].

Leptospirosis is an infectious disease endemic in the Philippines with numerous cases reported as aftermaths of typhoons especially after heavy flooding [7]. Infected patients would typically present with mild fever or in severe cases have multiorgan failure affecting in particular the kidneys and lungs [8]. Human leptospirosis is caused by highly invasive pathogenic leptospire which are capable of surviving and growing in tissues [9], as these were isolated from the blood samples of leptospirosis patients suggesting the pathogen's potential in successfully evading the natural defense system of the host [10]. In severe leptospirosis with pulmonary hemorrhages, human immune response was associated with elevated alveolar macrophages stimulating polymorphonuclear leukocytes resulting in inflammatory mediators and reactive intermediates production [11].

Tobacco smoke and leptospirosis directly compromise the host immune system [12]. A diminished macrophages phagocytic function has been established even in acute tobacco smoke exposure [1,13,14], whereas a significant diminished clearance ability and bactericidal activity were noted in chronic exposure [14]. In spite of the ability of the bone marrow-derived macrophages in degrading leptospire, a population of these pathogens was identified within a membrane compartment suggesting their survival and replication ability and subsequent invasion to certain human organs [15]. Macrophages are considered important cells of the innate immunity, once the pathogens are phagocytosed and degraded, chemokines and cytokines are produced, and antigens are presented for the adaptive immune system regulating the host immune response [16]. Bacterial infection and smoking impairing the functions of macrophages and T-cells imply that both leptospirosis and tobacco smoking act synergistically on common molecular targets. Hence, the dynamics of leptospirosis and smoking in the impairment of human immune system was captured by a system of ordinary differential equations. Parameter estimates and findings in the present study, facilitated by further molecular studies involving human immune responses under varied severity of leptospiremia, can eventually aid in addressing the inadequacy of antibiotic therapy in advanced and severe leptospirosis cases and in formulating prevention and control measures such as vaccine development.

MATERIAL AND METHODS

Biological Systems Model

The interaction between the macrophage and a pathogen has always been involved in the elucidation of the pathogenesis of infections [17]. Leptospirosis induces apoptosis in macrophages by activating specific proteases in a dose- and time-dependent fashion [18]. To determine the synergy of leptospirosis and smoking in the impairment of human immune system, mathematical models based on ordinary differential equations were established.

In the proposed model, T-cells were divided into three classes, namely the normal (T), smoking-impaired (T_S), and leptospira-infected (T_L) T-cells (Figure 1). Likewise, macrophages were divided into three classes: normal (M), smoking-impaired (M_S), and leptospira-infected (M_L) macrophages. The leptospire population is denoted by L.

In the absence of an infection, production of normal T-cells (T) has a constant rate (r) [19] and the population T suffers mortality at a rate γ_T [20]. When there is an infection, these normal T-cells are attacked by the population of leptospire (L) and by the infected macrophages (M_L) at a rate α_1 and μ , respectively. Smoking impairs normal T-cells at a rate δ [21] converting to impaired T-cells (T_S) which are then subsequently attacked at a rate α_2 by leptospire (L) and suffer mortality at a rate γ_{T_S} . When the normal (T) and impaired (T_S) T-cells are infected at a rate α_1 and α_2 , respectively, the population of infected (T_L) T-cells increases, but is also reduced as T_L is subjected to γ_{T_L} mortality rate.

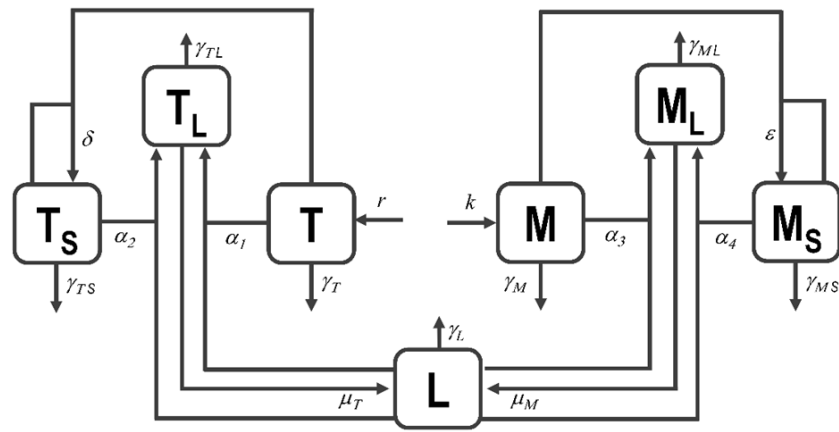

Figure 1. Dynamics involving smoking and leptospirosis in the impairment of human immune system.

Normal macrophages (M) are constantly produced and suffer mortality at a rate k [22] and γ_M [21], respectively. In addition, these normal macrophages are impaired by smoking at a rate ϵ and are attacked by leptospire at a rate α_3 . The population of impaired macrophages (M_S) is a result of the smoking impairment of the normal macrophages at a rate ϵ and is reduced as these suffer mortality at rate γ_{MS} [21]. Amplification of the infected macrophages (M_L) is due to the infection from the normal (M) and smoking-impaired (M_S) macrophages at a rate α_3 and α_4 , respectively, but restricted by the mortality rate γ_{ML} . The active interactions between leptospire and macrophages resulted to the invasion of the pathogen and subsequent macrophage apoptosis [18].

The leptospire population (L) is augmented from the infected macrophages (M_L) and T-cells (T_L) at a rate μ_M and μ_T , respectively. However, the population L decreases due to the γ_L mortality rate. Suppose, a leptospire is responsible for each new infection, then the population L further diminishes when the bacteria fuse with the normal (M) and impaired (M_S) macrophages at a rate α_3 and α_4 , respectively; and with the normal (T) and impaired (T_S) T-cells at a rate α_1 and α_2 , respectively.

In this study, it is assumed that tobacco smoking affects all cells as toxic substances from tobacco smoking diffuse via cell-to-cell contact. However, the present study assumed that tobacco smoking has no effect on the leptospire population. The total T-cell population is equal to $T + T_S + T_L$, whereas $M + M_S + M_L$ is the total macrophage population. Macrophages in a tissue have a half-life of 90 days [23]. Initial macrophage count is assumed to be 200 macrophages/ μL , and all macrophages are capable of being infected. Based on these specified assumptions, the systems model was described by Equations (1) to (7).

$$\frac{dT}{dt} = r - \alpha_1 LT - \mu M_L T - \delta T_S T - \gamma_T T, \quad (1)$$

$$\frac{dT_S}{dt} = \delta T_S T - \alpha_2 LT_S - \gamma_{TS} T_S, \quad (2)$$

$$\frac{dT_L}{dt} = \alpha_1 LT + \mu M_L T + \alpha_2 LT_S - \gamma_{TL} T_L - \mu_T T_L, \quad (3)$$

$$\frac{dM}{dt} = k - \alpha_3 LM - \epsilon M_S M - \gamma_M M, \quad (4)$$

$$\frac{dM_S}{dt} = \epsilon M_S M - \alpha_4 LM_S - \gamma_{MS} M_S, \quad (5)$$

$$\frac{dM_L}{dt} = \alpha_3 LM + \alpha_4 LM_S - \mu M_L T - \gamma_{ML} M_L - \mu_M M_L, \quad (6)$$

$$\frac{dL}{dt} = \mu_T T_L + \mu_M M_L - \alpha_1 LT - \alpha_2 LT_S - \alpha_3 LM - \alpha_4 LM_S - \gamma_L L, \quad (7)$$

As described in Equation 1, normal T-cell (T) population changes with respect to time as a function of the inflow r in T and the outflow $\gamma_T T$ which represents the increase due to the production and the decrease due to the natural mortality of normal T-cells, respectively. The outflow $\alpha_1 LT$ represents reduction in the T-cell

population due to the presence of infection by leptospire L, where the normal T-cells (T) are infected and converted to infected T-cells (T_L) at an infection rate α_1 . Another outflow in T is δT_S which corresponds to the reduction in the T-cell population when smoking impairs normal T-cells (T) at a rate δ . Lastly, by means of cell-to-cell transmission of infection, the outflow $\mu M_L T$ indicates a decrease in the population in which normal T-cells (T) are attacked at a rate μ by the infected macrophages (M_L) and are converted to infected T-cells (T_L). The process in obtaining the remaining six ordinary differential equations is similar to the first ordinary differential equation.

Parameter Values

The parameter values in the model were either estimated or based on the available literature (Table 1). For the estimated parameters, approximations were based on the properties and dynamics discussed in the literature. For instance, the smoking impairment rate ε for macrophages should be greater than the smoking impairment rate δ for T-cells as macrophages are severely affected by smoking than T-cells [3,4]. It is also assumed that infection rate is greater than the smoking impairment rate. In the conversion of normal immune cells to infected cells, infection rate for normal macrophages (α_3) is assumed to be greater than the smoking impairment rate (ε) for macrophages because impaired cells have impaired metabolic processes rendering less susceptible to attack [24,25,26]. Similarly, infection rate α_1 for normal T-cells has to be higher than the impairment rate δ for T-cells due to smoking. When smoking-impaired cells are converted to infected cells, infection rate α_4 for the smoking-impaired macrophages and infection rate α_2 for smoking-impaired T-cells were higher compared with the infection rates in normal cells as susceptibility to bacterial infections is magnified by tobacco use [27,28].

Table 1. Descriptions, reference values, and estimates of the model parameters.

Parameter	Description	Value	Reference	Units
r	T-cells recruitment constant	0.3288	[19]	day ⁻¹
k	Macrophages recruitment rate	0.0876	[22]	cell . day ⁻¹ . ml ⁻¹
γ_T	T-cells natural mortality rate	5.48×10^{-5}	[20]	day ⁻¹
γ_M	Macrophages natural mortality rate	9.62×10^{-6}	[21]	day ⁻¹
γ_L	Leptospire natural mortality rate	5.5×10^{-3}	[31]	day ⁻¹
ε	Macrophage smoking impairment rate	1.096×10^{-5}	[21]	day ⁻¹
δ	T-cells smoking impairment rate	6.85×10^{-6}	[21]	day ⁻¹
γ_{TS}	Impaired T-cells mortality rate	6.58×10^{-7}	[21]	day ⁻¹
γ_{MS}	Impaired macrophages mortality rate	4.11×10^{-5}	[21]	day ⁻¹
γ_{TL}	Infected T-cells mortality rate	1×10^{-4}	Estimated	day ⁻¹
γ_{ML}	Infected macrophages mortality rate	4×10^{-4}	Estimated	day ⁻¹
μ	Infected macrophages infection rate of normal T-cells	8×10^{-5}	Estimated	day ⁻¹
μ_T	Leptospire replication rate in infected T-cells	0.06	Estimated	day ⁻¹
μ_M	Leptospire replication rate in infected macrophages	0.03	Estimated	day ⁻¹
α_1	Infection rate for normal T-cells	5×10^{-5}	Estimated	day ⁻¹
α_2	Infection rate for impaired T-cells	3×10^{-4}	Estimated	day ⁻¹
α_3	Infection rate for normal macrophages	1×10^{-4}	Estimated	day ⁻¹
α_4	Infection rate for impaired macrophages	5×10^{-4}	Estimated	day ⁻¹

The mortality rates of the infected macrophages (γ_{ML}) and infected T-cells (γ_{TL}) are greater than the mortality rates of the normal and smoking-impaired cells [29], whereas the death rate of the smoking-impaired cells is slower than the normal cells primarily because the former have impaired metabolic processes rendering these less susceptible to attack and delayed death [24,25,26].

Cell-to-cell transmission of infection is relatively faster compared to pathogens infecting immune cells [30]. Hence, infected macrophages (M_L) transmit the infection to T-cells at a rate μ , which is faster than infection rate α_1 for the normal T-cells [30]. As the normal macrophages (M) attempt to phagocytose and degrade the pathogens than the normal T-cells (T), the replication rate μ_M is lower than μ_T .

RESULTS AND DISCUSSION

In this paper, three systems were presented: (1) disease-free state, (2) presence of leptospira infection only, and (3) presence of both leptospira infection and smoking.

Disease-free State

For the disease-free system, under normal physiologic conditions, the human immune system describes the rate of change of T-cell population as

$$\frac{dT}{dt} = r - \gamma_T T, \quad (8)$$

while the change in macrophage population with respect to time was described as

$$\frac{dM}{dt} = k - \gamma_M M. \quad (9)$$

The T-cell population has disease-free equilibrium at

$$T = \frac{r}{\gamma_T}, \quad (10)$$

with the population of T-cells described as

$$T(t) = \frac{r}{\gamma_T} + e^{-\gamma_T t} \left(T_0 - \frac{r}{\gamma_T} \right), \quad (11)$$

with $r = 0.3288$ [19] and $T = 5.48 \times 10^{-5}$ [20]. As time (t) approaches infinity, T-cell population approaches 6,000 cells/mL. On the other hand, the macrophage population is described by

$$M(t) = \frac{k}{\gamma_M} + e^{-\gamma_M t} \left(M_0 - \frac{k}{\gamma_M} \right) \quad (12)$$

and the disease-free equilibrium population for macrophages was calculated to be 9,135 cells/mL, when $k = 0.0876$ [22] and $M = 9.62 \times 10^{-6}$ [21].

System with Leptospira Infection

The population of T-cells when exposed to leptospira changes with respect to time and is described by

$$\frac{dT}{dt} = r - \alpha_1 LT - \mu M_L T - \gamma_T T \quad (13)$$

and

$$\frac{dT_L}{dt} = \alpha_1 LT + \mu M_L T - \gamma_{TL} T_L - \mu_T T_L, \quad (14)$$

while the population of macrophages when exposed to leptospira changes with respect to time and is described by

$$\frac{dM}{dt} = k - \alpha_3 LM - \gamma_M M \quad (15)$$

and

$$\frac{dM_L}{dt} = \alpha_3 LM - \mu M_L T - \gamma_{ML} M_L - \mu_M M_L. \quad (16)$$

The rate at which the population of leptospira changes with respect to time is described by

$$\frac{dL}{dt} = \mu_T T_L + \mu_M M_L - \alpha_1 LT - \alpha_3 LM - \gamma_L L. \quad (17)$$

In the numerical simulation of this system, incremental changes in the population of leptospires ranging from 2,000 to 8,000 cells/mL (Figure 2) were examined which subsequently reflected the behavior of immune cells at these different levels of bacterial load (Figure 3). The interaction of the pathogen with macrophages has been elucidated in bacterial infection pathogenesis [17]. Among individuals with leptospirosis, blood or serum bacterial load ranges from 10² to 10⁶ leptospires/mL [32]. The increase in the bacterial load (Figure 2) has resulted to a corresponding reduction in the number of normal cell populations (Figure 3) and these normal cells were converted into infected cells (Figure 3C-3D). At a bacterial load of 2,000 cells/mL, the infected cells declined in the first few days as the normal immune cells attempt to eradicate the bacteria. However, with the given bacterial load, infected cells persisted which explains the decline in the normal cell populations (Figure 3A-3B) and the corresponding rise in the population of infected cells (Figure 3C-3D). The trend remains as the bacterial load increases, and the persistence of the bacteria remains longer inside the host.

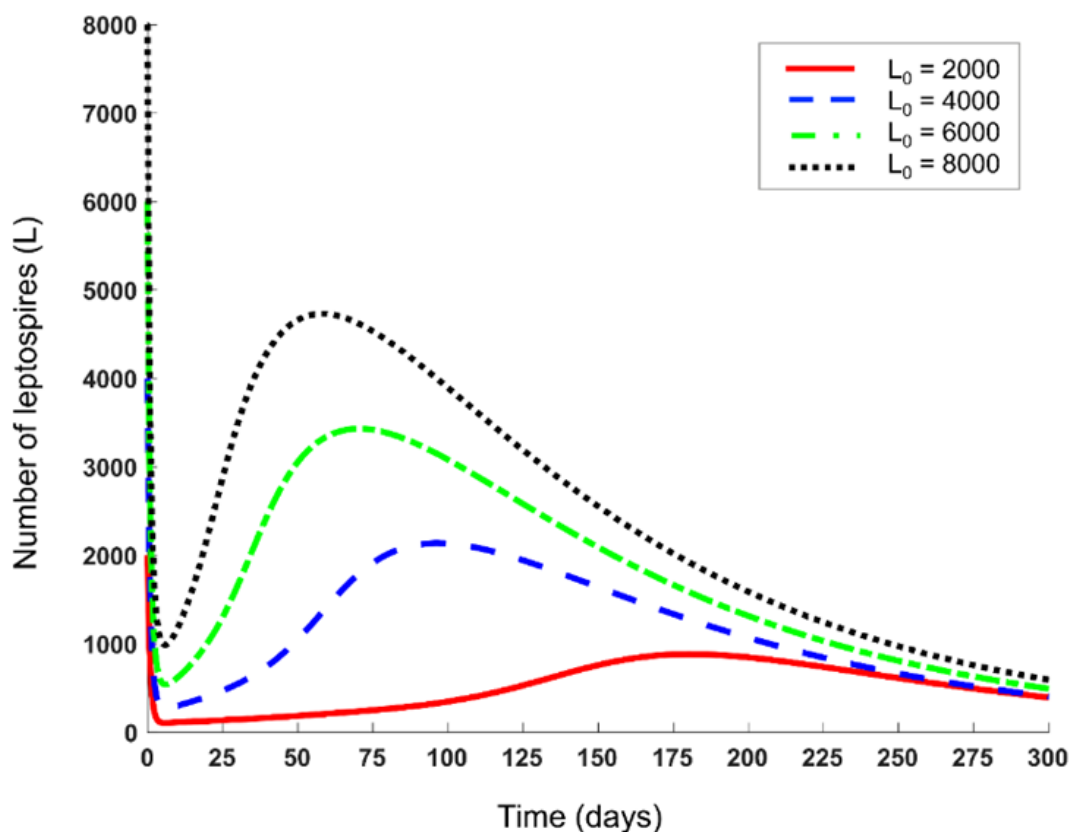

Figure 2. Temporal behavior of the leptospire population at varying initial load in the absence of smoking.

The behavior of the normal cells can be observed to be in the reverse fashion as with the number of leptospires (Figure 3A-3B). As the number of leptospires increases, the population of the normal cells decreases. When leptospire population increases, the number of infected immune cells also increases. The infection persisted beyond 150 days when the inoculum was at 2,000 cells/mL, but when the bacterial load was increased to 4,000 cells/mL, the conversion of normal immune cells to infected macrophages occurred in the first 30-45 days and T-cells in 90 days post-infection. A similar observation with the immune cells exposed to 2,000 cells/mL inoculum, the infected immune cells decreased in the first few days due to the phagocytic function of normal immune cells. A faster conversion rate of the normal cells has been observed when the bacterial load was increased to 4,000 cells/mL. These findings suggest that the rate of conversion of normal immune cells to infected cells is dose-dependent. Moreover, the persistence of such similar behavior was observed when the inoculum was increased to 6,000 and 8,000 cells/mL (Figure 3). The infection had converted the normal macrophages and T-cells in the first 15-20 days since exposure which explains the reduction in the normal cell populations (Figure 3A-3B) and the subsequent persistence of the infection until day 30. These findings demonstrate the dose- and time-dependence bacterial induction of apoptosis in macrophages [18].

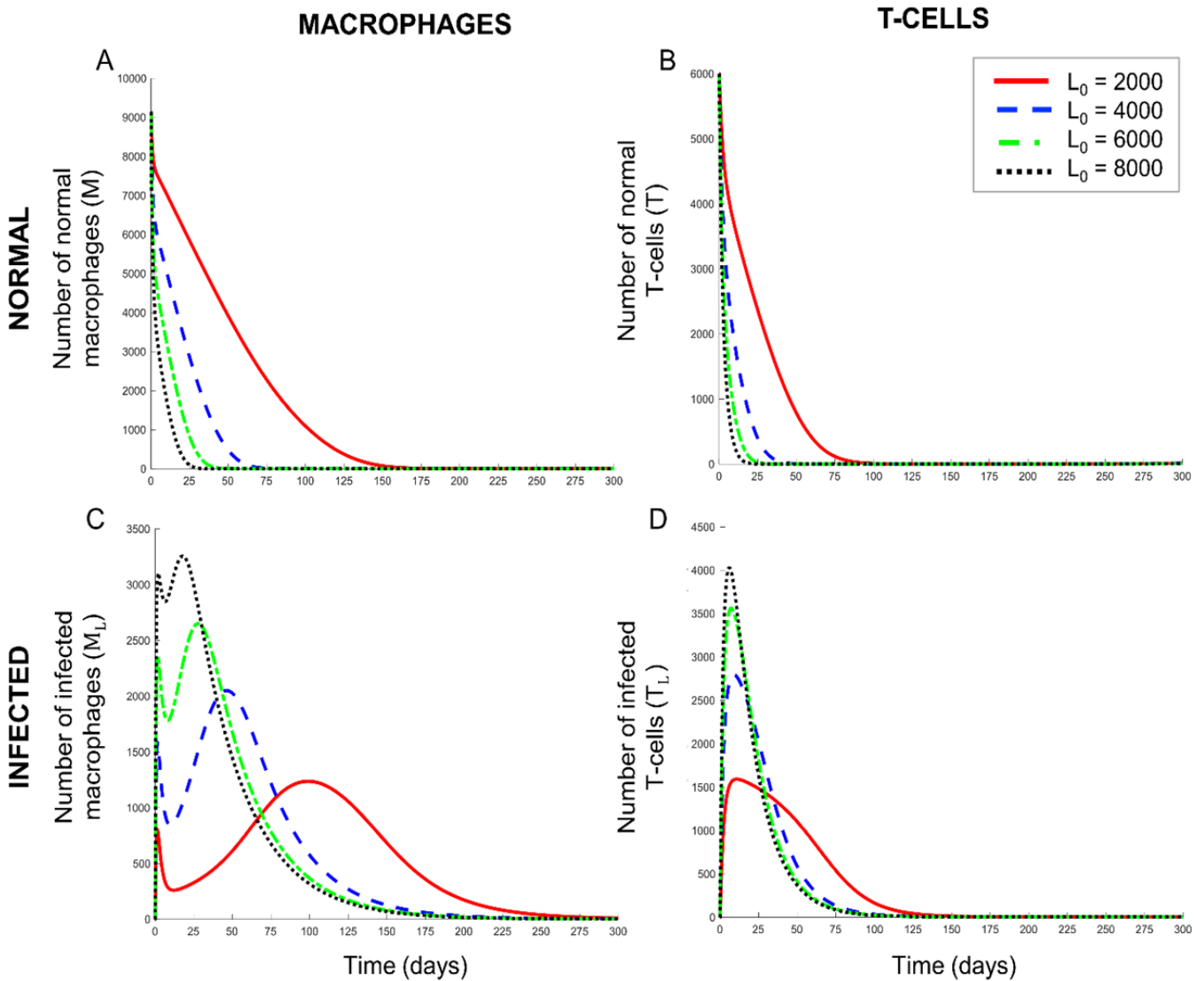

Figure 3. Behavior of the (A) normal macrophages, (B) normal T-cells, (C) infected macrophages, and (D) infected T-cells under varying bacterial loads in the absence of smoking.

Immune response in leptospira infection among smokers

Human immune cells, particularly macrophages, are efficient in the phagocytosis and clearance of pathogens, but exposure to toxic environmental factors such as smoking can suppress these phagocytic activities [33]. In Figure 4, the behavior of the bacterial population in the system over time in the presence of smoking is described. Tobacco smoke contains nicotine-enriched aerosol that causes alveolar deposition and increases absorption in the systemic blood which renders the host higher vulnerability to infectious diseases [34]. As the antibacterial activity of the immune cells is compromised by exposure to tobacco smoke [27], when the infection sets in the already impaired cell populations, these cells become even more susceptible to the infection which further weakens the immune system. Thus, given a 2,000 cells/mL bacterial load, the normal cell population rapidly declined in roughly 60 days (Figure 5A-5B). The smoking-impaired cells increased in the first few days, but eventually declined beyond 40 days (Figure 5C-5D) due to the presence of infection while the persistence of leptospire population is within 150 days (Figure 4).

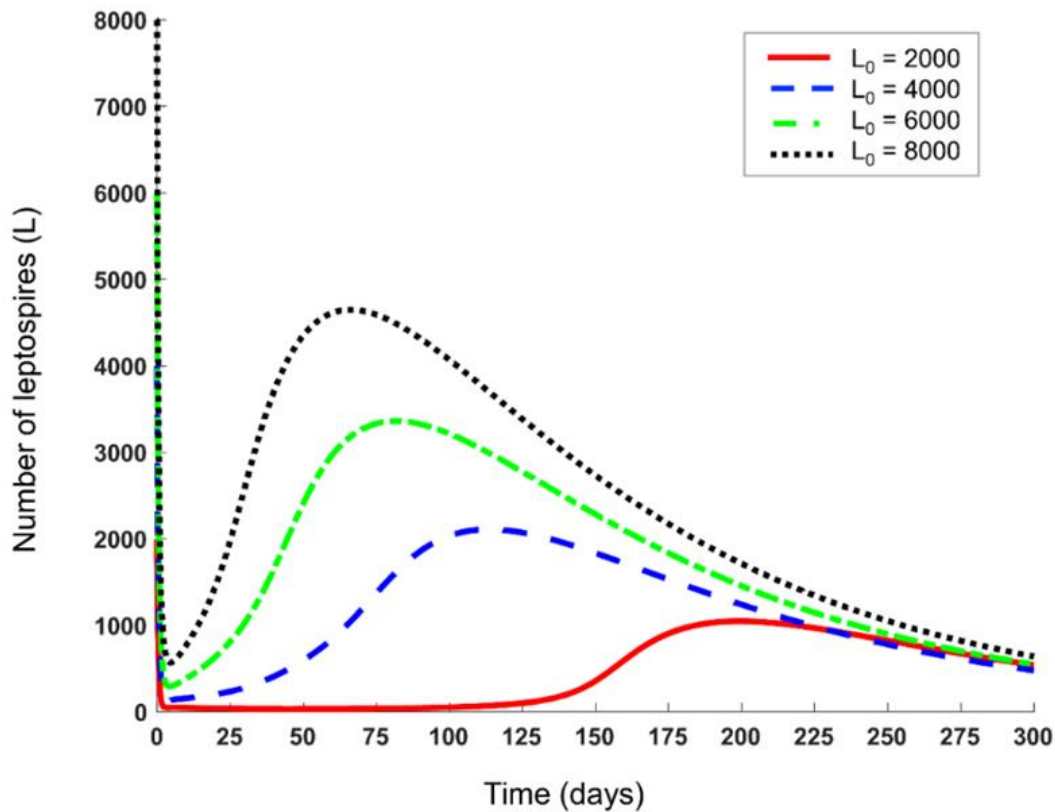

Figure 4. Behavior of the bacterial population in the system over time in the presence of smoking.

Regarding leptospirosis among smokers with an inoculum of 4,000 cells/mL, the infected population increased at a relatively faster rate since the normal and smoking-impaired cells were converted to infected cells (Figure 5). The effect of infection among smokers resulted in a rapid decline in the normal cell populations (Figure 5). When exposed to a bacterial load of 6,000 cells/mL and 8,000 cells/mL, normal cell populations likewise declined, and a significant conversion of these normal cells to infected cells was identified (Figure 5). Longer persistence of infection and more predominance of leptospires were observed in higher bacterial load (Figure 4). Due to smoking, the immune cells weaken and become more susceptible to infection [27]. Hence, if the immune cells were already smoking-impaired, by the time infection sets in, immune response displayed a rapid destruction in the T-cell and macrophage populations suggesting the synergistic effect of smoking and leptospirosis. When both smoking and infection were present, immune cells were converted to infected cells at a faster rate (Figure 5) when compared with infection among non-smokers (Figure 3).

The immune system is known to protect an individual from pathogens, but it is impaired among smoking individuals. Both the innate and adaptive immunity become susceptible to infections due to cigarette smoking [25]. When the host is infected, with the rapid replication of the pathogen, and once its population exceeded the maximum capacity of the macrophages, it will spread all throughout the organs which can subsequently lead to death [35]. The complex dynamics of pathogen and host regulates the activation of immune cells which is associated with the degree of bacteremia, and consequently with the clinical outcome of the host [36,37].

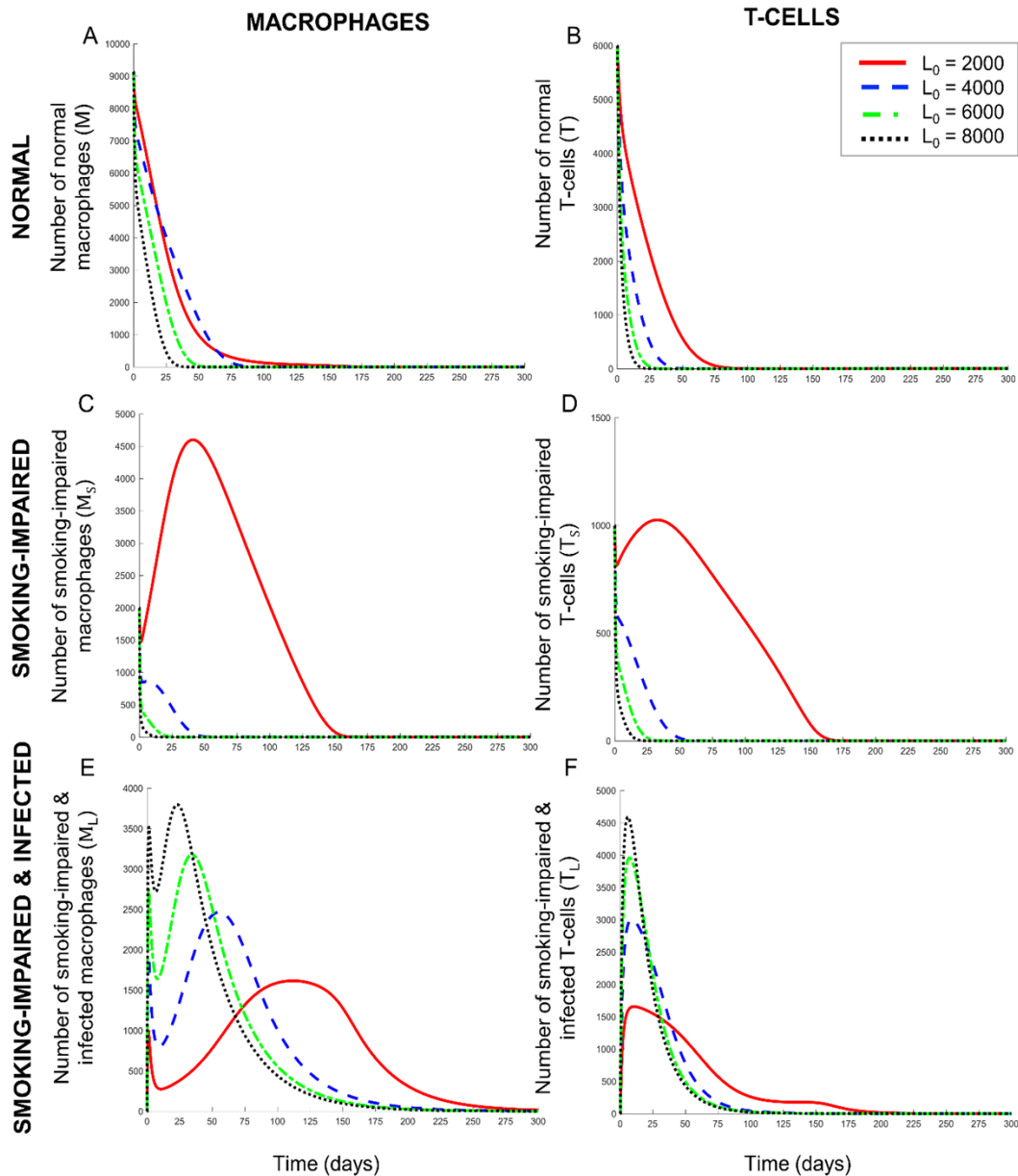

Figure 5. Behavior of (A) normal macrophages, (B) normal T-cells, (C) smoking-impaired macrophages, (D) smoking-impaired T-cells, (E) smoking-impaired and infected macrophages, and (F) smoking-impaired and infected T-cells under varied bacterial loads.

CONCLUSION

How the pathogens interact with human immune cells had been elucidated in the pathogenesis of several bacterial infections. The synergy of leptospirosis and smoking in the impairment of human immune system was described using a system of ordinary differential equations. Leptospirosis resulted in a significant decrease in T-cell and macrophage populations. Disease-free and synergistic immune response to smoking and leptospirosis revealed predominance of macrophages over T-cells. The persistence of leptospirosis primarily depends on the initial bacterial load and with concomitant smoking exposure of an infected individual, synergistic immune response has been established as reflected in the rapid decline in T-cell and macrophage populations. Exposure of human immune cells to toxic environmental factors such as smoking suppressed their phagocytic activities and increased vulnerability to infectious diseases.

Funding: This research did not receive any external funding.

Conflicts of Interest: The authors declare no conflict of interest.

REFERENCES

1. Sopori M. Effects of cigarette smoke on the immune system. *Nat Rev Immunol.* 2002;2(5):372-7.
2. Talhout R, Schulz T, Florek E, van Benthem J, Wester P, Opperhuizen A. Hazardous compounds in tobacco smoke. *Int J Environ Res Public Health.* 2011;8(2):613-28.
3. Kalra R, Singh SP, Savage SM, Finch GL, Sopori ML. Effects of cigarette smoke on immune response: chronic exposure to cigarette smoke impairs antigen-mediated signaling in T cells and depletes IP3-sensitive Ca²⁺ stores. *J Pharmacol Exp Ther.* 2000;293(1):66-71.
4. Herr C, Beisswenger C, Hess C, Kandler K, Suttorp N, Welte T, et al. R Bals for the CAPNETZ Study Group, Suppression of pulmonary innate host defence in smokers. *Thorax.* 2009;64(2):144-9.
5. Lee J, Taneja V, Vassallo R. Cigarette smoking and inflammation: cellular and molecular mechanisms. *J Dent Res.* 2012;91(2):142-9.
6. Piao W, Campagnolo D, Dayao C, Lukasi RJ, Wui J, Shi F. Nicotine and inflammatory neurological disorders. *Acta Pharmacol Sin.* 2009;30(6):715-22.
7. Sumalapao DEP, del Rosario BKM, Suñga LBL, Walther CC, Gloriani NG. Frequency of typhoon occurrence accounts for the Poisson distribution of human leptospirosis cases across the different geographic regions in the Philippines. *Asian Pac J Trop Med.* 2019;12(1):38-42.
8. Bharti AR, Nally JE, Ricaldi JN, Matthias MA, Diaz MM, Lovett MA, et al. Leptospirosis: a zoonotic disease of global importance. *Lancet Infect Dis.* 2003;3(12):757-71.
9. McBried AJA, Athanazio DA, Reis MG, Ko AL. Leptospirosis. *Curr Opin Infect Dis.* 2005;18(5):376-86.
10. Cinco M, Banfi E, Soranzo MR. Studies on the interaction between macrophages and leptospires. *J Gen Microbiol.* 1981;124:409-13.
11. Marinho M, Oliveira-Junior IS, Perr SHV, Piero JR, Pavanelli TF, Salomao R. Response activity of alveolar macrophages in pulmonary dysfunction caused by *Leptospira* infection. *J Venom Anim Toxins incl Trp Dis.* 2008;14(1):58-70.
12. Tubiana S, Mikulski M, Becam J, Lacassin F, Lefèvre P, Gourinat AC, et al. Risk factors and predictors of severe leptospirosis in New Caledonia. *PLoS Negl Trop Dis.* 2013;7(1):e1991.
13. Hirono Y, Kawazoe A, Nose M, Sakura M, Takeuchi M. Cigarette smoke induce alteration of structure and function in alveolar macrophages. *Int. J. Biosci. Biochem. Bioinform.* 2013;3(2):125-8.
14. Thomas WR, Holt PG, Keast D. Cigarette smoke and phagocyte function: effect of chronic exposure *in vivo* and acute exposure *in vitro*. *Infect Immun.* 1978;20(2):468-75.
15. Toma C, Okura N, Takayama C, Suzuki T. Characteristic features of intracellular pathogenic *Leptospira* in infected murine macrophages. *Cell Microbiol.* 2011;13(11):1783-92.
16. Xue F, Zhao X, Yang Y, Zhao J, Yang Y, Cao Y, et al. Responses of murine and human macrophages to leptospiral infection: a study using comparative array analysis. *Plos Negl Trop Dis.* 2013;7(10):e2477.
17. Navarre WW, Zychlinsky A. Pathogen-induced apoptosis of macrophages: a common end for different pathogenic strategies. *Cell Microbiol.* 2000;2(4):265-73.
18. Jin D, Ojcius DM, Sun D, Dong H, Luo Y, Mao Y, Yan J. *Leptospira interrogans* induces apoptosis in macrophages via caspase-8- and caspase-3-dependent pathways. *Infect Immun.* 2009;77(2):799-809.
19. Das P, Mukherjee D, Sen A, Mukandavire Z, Chiyaka C. Analysis of an in-host model for HIV dynamics with saturation effect and discrete time delay. *Nonlinear Dynamics and Systems Theory.* 2011;11(2):125-36.
20. Wang X, Song X. Global stability and periodic solution of a model for HIV infection of CD4+ T cells. *Appl Math Comput.* 2007;189(2):1331-40.
21. Irunde JI, Luboobi LS, Nkansah-Gyekye Y. Modeling the effect of tobacco smoking on the in-host dynamics of HIV/AIDS. *J Math Comput Sci.* 2016;6(3):406-36.
22. Adams BM, Banks HT, Davidian M, Kwon H, Tran H, Wynne S, et al. HIV dynamics: Modeling, data analysis, and optimal treatment protocols. *J Comput Appl Math.* 2005;184(1):10-49.
23. Duffin RP, Tullis RH. Mathematical models of the complete course of HIV infection and AIDS. *J. Theor. Med.* 2002;4(4):215-21.
24. Loftus R, Finlay D. Immunometabolism: cellular metabolism turns immune regulator. *J Biol Chem.* 2016;291(1):1-10.
25. Qiu F, Liang C, Liu H, Zeng Y, Hou S, Huang S, et al. Impacts of cigarette smoking on immune responsiveness: Up and down or upside down? *Oncotarget.* 2017;8(1):268-84.
26. Kim J. Regulation of immune cell functions by metabolic reprogramming. *J Immunol Res.* 2018;1-12.
27. Bagaitkar J, Demuth D, Scott D. Tobacco use increases susceptibility to bacterial infection. *Tob Induc Dis.* 2008;4(1):1-10.
28. Feldman C, Anderson R. Cigarette smoking and mechanisms of susceptibility to infections of the respiratory tract and other organ systems. *J Infect* 2013;67(3):169-84.
29. Jones B. Dying cells can warn their neighbors in an attempt to stave off infection. 2017 [cited 2018 August 30]. Available from: <https://futurism.com/dying-cells-can-warn-their-neighbors-in-an-attempt-to-stave-off-infection/>.
30. Agosto L, Uchil P, Mothes W. HIV cell-to-cell transmission: effects on pathogenesis and antiretroviral therapy. *Trends Microbiol.* 2015;23(5):289-95.
31. Cox S. Leptospirosis a bacterial disease that's spreading. 2013 [cited 2018 August 30]. Available from: <https://www.thewildest.com/dog-health/leptospirosis>.

32. Musso D, La Scola B. Laboratory diagnosis of leptospirosis: a challenge. *J Microbiol Immunol Infect.* 2013;46(4):245-52.
33. Karavitis J, Kovacs EJ. Macrophage phagocytosis: effects of environmental pollutants, alcohol, cigarette smoke, and other external factors. *J Leukoc Biol.* 2011;90(6):1065-78.
34. Arnson Y, Shoenfeld Y, Amital H. Effects of tobacco smoke on immunity, inflammation and autoimmunity. *J Autoimmun.* 2010;34(3):J258-65.
35. Cao Q, Harris DC, Wang Y. Macrophages in kidney injury, inflammation, and fibrosis. *Physiology (Bethesda).* 2015;30(3):183-94.
36. Truccolo J, Serais O, Merien F, Perolat P. Following the course of human leptospirosis: evidence of a critical threshold for the vital prognosis using a quantitative PCR assay. *FEMS Microbiol Lett.* 2001;204(2):317–21.
37. Klimpel GR, Matthias MA, Vinetz JM. *Leptospira interrogans* activation of human peripheral blood mononuclear cells: preferential expansion of TCR gamma delta+ T cells vs TCR alpha beta+ T cells. *J Immunol.* 2003;171(3):1447-55.



© 2023 by the authors. Submitted for possible open access publication under the terms and conditions of the Creative Commons Attribution (CC BY NC) license (<https://creativecommons.org/licenses/by-nc/4.0/>).