

Bioelectrical impedance spectroscopy for the assessment of body fluid volumes of term neonates

D.M. Ferreira¹
and M.N. Souza^{1,2}

¹Programa de Engenharia Biomédica, COPPE, and ²Departamento de Engenharia Eletrônica, Universidade Federal do Rio de Janeiro, Rio de Janeiro, RJ, Brasil

Abstract

The assessment of fluid volume in neonates by a noninvasive, inexpensive, and fast method can contribute significantly to increase the quality of neonatal care. The objective of the present study was to calibrate an acquisition system and software to estimate the bioelectrical impedance parameters obtained by a method of bioelectrical impedance spectroscopy based on step response and to develop specific equations for the neonatal population to determine body fluid compartments. Bioelectric impedance measurements were performed by a laboratory homemade instrument. The volumes were estimated in a clinical study on 30 full-term neonates at four different times during the first month of life. During the first 24 hours of life the total body water, extracellular water and intracellular water were 2.09 ± 0.25 , 1.20 ± 0.19 , and 0.90 ± 0.25 liters, respectively. By the 48th hour they were 1.87 ± 0.27 , 1.08 ± 0.17 , and 0.79 ± 0.21 liters, respectively. On the 10th day they were 2.02 ± 0.25 , 1.29 ± 0.21 , and 0.72 ± 0.14 liters, respectively, and after 1 month they were 2.34 ± 0.27 , 1.62 ± 0.20 , and 0.72 ± 0.13 liters, respectively. The behavior of the estimated volume was correlated with neonatal body weight changes, leading to a better interpretation of such changes. In conclusion, this study indicates the feasibility of bioelectrical impedance spectroscopy as a method to help fluid administration in intensive care neonatal units, and also contribute to the development of new equations to estimate neonatal body fluid contents.

Key words

- Bioelectrical impedance spectroscopy
- Body water
- Extracellular water
- Intracellular water
- Neonatal handling

Correspondence

M.N. Souza
Programa de Engenharia Biomédica
COPPE, UFRJ
Caixa Postal 68510
21945-970 Rio de Janeiro, RJ
Brasil
Fax: +55-21-2562-8591
E-mail: souza@peb.ufrj.br

Research supported by PRONEX,
CAPES, CNPq, and Universidade
Federal do Rio de Janeiro.

Received January 14, 2004
Accepted July 27, 2004

Introduction

Neonatal care has a strong influence on child development and survival, especially in the case of low body weight newborns who are considered to be at risk. Among several kinds of neonatal care, water balance monitoring has become important for preterm neonates because they show variable needs of fluid replacement. A reduced fluid intake can cause dehydration, electrolyte imbalance,

and arterial hypotension. On the other hand, an excessive fluid intake can cause peripheral edema, patent ductus arteriosus, congestive heart failure, bronchopulmonary dysplasia, cerebral intraventricular hemorrhage, and necrotizing enterocolitis (1).

Some studies correlate body weight changes with the prediction of total body water (TBW). Nevertheless, this relationship cannot detect changes in intra- and extracellular volume (1). In cases in which

changes in extracellular volume are observed without an alteration in total body volume, weight is not a reliable parameter to monitor fluid balance. Because different variables can affect neonatal fluid volumes, fluid requirements must be based on the individual need of each baby. Thus, a noninvasive technique to measure TBW, as well as its compartments, can contribute to improving neonatal care.

The original studies using whole-body impedance as a measure of TBW were published a number of years ago by Thomasset (2). At present, bioelectrical impedance analysis is probably the method most frequently used due to the relatively inexpensive cost of the basic instrument, its easy operation, and its portability.

Bioelectrical impedance measures electric parameters (i.e., resistance and reactance) and this information is converted to a volume estimate based on the conductor volume principle. This theory assumes that the body can be modeled as a cylinder filled with a conductive material with constant resistivity, with a length that is proportional to the subject's height (Ht). The conducting volume is assumed to be proportional to the Ht^2/R ratio, called the impedance index. It should be noted, however, that the human body is not a cylindrical conductor, nor are its tissues electrically isotropic. Due to this limitation, another equation has been used by analogy to estimate TBW: $a Ht^2/R + c$, where a is a proportional specific constant of the population and c is an adjustment constant.

Several studies (3-6) include anthropometric predictors (i.e., weight, age, gender, race, waist-to-hip ratio, body mass index) in the equation to obtain a better correlation with gold standards, but many of these equations are population specific and no physiological justification for the added terms has been provided. Bioelectrical impedance equations have been developed for newborn infants and toddlers, children and adolescents, and for adults of all ages. The most important of these equations is that they show a good correlation with

TBW measured by gold standard methods (deuterium dilution and $H_2^{18}O$ dilution).

Hoffer et al. (7) reported a good correlation between body impedance and body water volume ($r = 0.92$) in adults in various degrees of hydration. Goran et al. (8) showed a correlation ($r = 0.88$) between TBW measured in 61 children and the equation proposed by Kushner and Schoeller (4).

The studies that assessed TBW in neonates reported a good correlation with bioelectrical impedance analysis. Tang et al. (9) found a correlation coefficient of 0.996. Mayfield et al. (3) also showed a good correlation ($r = 0.976$) and Wilson et al. (10) reported a correlation of 0.96. Lingwood et al. (6) developed regression models for the prediction of extracellular volume in preterm neonates and showed a good correlation between bromide space and the resulting equations ($r = 0.986$).

The present study was carried out to calibrate the acquisition system and software that estimates the bioelectrical impedance parameters and to develop specific neonatal population equations to estimate intra- and extracellular fluids and TBW from bioelectrical impedance parameters. The bioelectrical impedance parameters were obtained by bioelectrical impedance spectroscopy (BIS) based on a step response (11) instead of the classical method of sinusoidal sweep. The basis of the BIS method will be presented, as well as a description of how the specific equations to estimate the fluid volumes were developed from the set of equations designed for adults and children (12), but not for neonates. The results, obtained in a clinical study involving 30 full-term neonates, were compared with clinical findings, indicating that the method seems to be feasible to assess body fluid and could contribute to increasing the quality of neonatal care.

Material and Methods

The BIS method used to assess the whole

body bioelectrical impedance parameters was the one proposed by Neves and Souza (11) and is based on the current response to a voltage step excitation (illustrated in Figure 1). The figure shows the classical model of whole body bioelectrical impedance consisting of R_e (extracellular resistance), R_i (intracellular resistance), and C_m (membrane capacitance), and also the simplified model of the electrode/tissue interface represented by electrode capacitance (C_e). The major advantage of this BIS method is the use of a smaller number of signals to characterize the bioelectrical impedance, since only one excitation signal scans all frequency components.

The current response can be expressed by Equation 1, where a faster exponential is associated with the membrane capacitance and a slower one with the electrode capacitance.

$$i(t) = i_p (k_1 e^{(p_1 t)} + k_2 e^{(p_2 t)}) \quad (\text{Eq. 1})$$

where i_p , k_1 , k_2 , p_1 , and p_2 are constants derived from the bioelectrical impedance parameters. For more details concerning the BIS method see Neves and Souza (11).

With this theoretical model of the current $i(t)$ and its analogous version experimentally obtained in the subject, BIS (R_e , R_i , C_m , and C_e) is estimated using a multiparametric optimization procedure. The algorithm to obtain the best set of parameters by fitting the theoretical expectation to the experimental data was based on the steepest descending gradient method. The system also supplies the R_{inf} (parallel association between R_e and R_i), which is related to TBW (13).

In the BIS method, a data acquisition card (National Instrument®, PCMCIA DAQCard model AI-16E-4, Autix, TX, USA) installed in a laptop framework is used for the generation of the step voltage excitation and for data acquisition. A specific program has been developed (LabView®, National Instruments) to handle data acquisition and

the estimate of bioelectrical impedance parameters.

In present study, bioelectrical impedance was measured with a prototype apparatus based on the principle described above, which was developed in the Biomedical Instrumentation Laboratory, Biomedical Engineering Program, Federal University of Rio de Janeiro, Rio de Janeiro, RJ, Brazil.

After the bioelectrical impedance parameters were measured, intracellular water (ICW) and extracellular water (ECW) could not be estimated by the original equations of De Lorenzo et al. (12) because they are inappropriate for neonates. This problem led to the development of a new set of equations that will now be presented.

De Lorenzo and colleagues (12) used models based on Hanai mixture theory to estimate body volumes for adults and correlated them with gold standard methods. According to these investigators, extracellular volumes can be calculated by:

$$ECW = k_{ECW} \left(\frac{Ht^2 \times Wt^{0.5}}{R_e} \right)^{2/3} \quad (\text{Eq. 2})$$

where Ht is subject height (cm), Wt is the weight (kg) and R_e the extracellular resistance (Ω). The term k_{ECW} was assumed to be constant ($k_{ECW} = 0.311$) and was defined by:

$$k_{ECW} = 10^{-3} \times \left(\frac{k_B^2 \times \rho ECW^2}{D_b} \right)^{1/3} \quad (\text{Eq. 3})$$

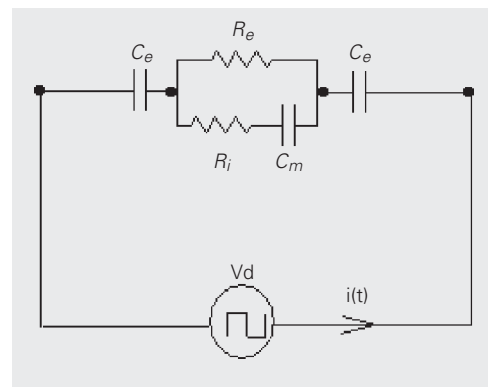

Figure 1. Model proposed by Neves and Souza (11) to calculate the current response to a voltage step excitation and to derive the bioelectrical impedance parameters (see text for more details). C_e = electrode capacitance; C_m = membrane capacitance; R_e = extracellular resistance; R_i = intracellular resistance; V_d = step voltage; $i(t)$ = current

where ρ_{ECW} is the resistivity of the extracellular fluid ($\rho_{ECW} = 41 \Omega \text{ cm}$), D_b is the total body density ($D_b = 1.05 \text{ kg/l}$), and K_B is a correcting factor for whole body measurement, which is obtained between the wrist and ankle taking into account the relative proportions of the leg, arm and trunk, and height. The term K_B is assumed to be constant and equal to 4.3. The extracellular resistivity (ρ_{ECW}), in turn, is obtained by:

$$\rho_{ECW} = \rho_0 (1 - c)^{3/2} \quad (\text{Eq. 4})$$

where ρ_0 is the actual resistivity of the conductive material ($250 \Omega \text{ cm}$) and c is the volumetric concentration of the nonconductive material contained in the mixture (0.672). At low frequencies this concentration can be calculated by:

$$c_1 = 1 - \frac{ECW}{V_{Tot}} \quad (\text{Eq. 5})$$

where V_{Tot} is the total body volume (Wt/D_b).

At high frequencies the volumetric concentration is estimated by:

$$c_2 = 1 - \frac{ECW + ICW}{V_{Tot}} \quad (\text{Eq. 6})$$

Since the extracellular and intracellular resistances (R_e and R_i) have been previously estimated by the BIS method, after the extracellular volume has been obtained, the intracellular volume can be calculated by an iterative procedure that solves Equation 7 for ICW.

$$\left(1 + \frac{ICW}{ECW}\right)^{5/2} = \left(\frac{R_e + R_i}{R_i}\right) \times \left(1 + \frac{k_p ICW}{ECW}\right) \quad (\text{Eq. 7})$$

In Equation 7 the term k_p , the ratio between the intracellular and extracellular resistivity (ρ_{ICW}/ρ_{ECW}), is set at 1.4, and the resistances are expressed in ohm. After the calculation of ECW and ICW, TBW can be

obtained by the simple addition of these two volumes.

The advantage of the approach of De Lorenzo et al. (12) is that it is not based on any specific population. This means that this approach can be used for any subject that presents the constants assumed by De Lorenzo and colleagues, i.e., subjects presenting a volumetric concentration of nonconductive material of about 0.672 and a ratio of intracellular to extracellular resistivity of about 1.4. Healthy adults and children normally fulfill these requirements. However, the assumption of these constants for neonates can lead to wrong estimations, because in this population the extracellular volume is higher than the intracellular volume (14-16), and this inversion, differently from the original assumption, modifies these constants.

Based on these considerations, it was important to adapt the equations of De Lorenzo et al. (12) to the neonatal population. This adaptation was started by calculating a new extracellular resistivity (ρ_{ECW}) from several volumetric concentrations (c) reported in the literature.

Tables 1 and 2 show the values of the volumetric concentrations c_1 and c_2 obtained at low and high frequencies, respectively, for several populations, as well as the basic parameters (\overline{ECW} , \overline{ICW} and $\overline{\text{Weight}}$) used to calculate such concentrations in Equations 5 and 6.

The basic assumption was to obtain from information reported in the literature mean values for the concentrations at low and high frequencies and then to derive a global mean concentration to replace the constant (c) originally used by De Lorenzo et al. (12). As shown in Table 1, for adults, the mean concentration of nonconductive material c , calculated as the average between the mean values of c_1 and c_2 , is around 0.59, a value near the one reported by De Lorenzo et al. (12). However, Table 2 shows that for the neonatal population the mean concentration

of nonconductive material presents a totally different value of about 0.43, justifying modifications in ρ_{ECW} and subsequently in k_{ECW} .

With the concentration of nonconductive material set at 0.43, a new ρ_{ECW} value for the neonatal population was obtained as:

$$\rho_{ECW_N} = \rho_0 (1 - c)^{3/2} = 250 (1 - 0.43)^{3/2} = 107 \Omega \text{ cm} \quad (\text{Eq. 8})$$

where the subscript N stands for the ρ_{ECW} value for neonates.

Due to the new value for ρ_{ECW} , the k_{ECW} constant was modified to:

$$k_{ECW_N} = 10^{-3} \left(\frac{k_B^2 \rho_{ECW_N}^2}{D_b} \right)^{1/3} = 10^{-3} \left(\frac{4.3^2 \times 107^2}{1.05} \right)^{1/3} = 0.59 \quad (\text{Eq. 9})$$

Table 1. Adult intra- (ICW) and extracellular (ECW) water volumes, weight and volumetric concentration of the nonconductive material.

Study	Population (N)	ECW (liters)	ICW (liters)	Weight (kg)	c_1	c_2
Cornish et al. (22)	Adults (60)	17.70 ± 3.80	22.10 ± 9.20	69.10 ± 12.70	0.73 ± 0.38	0.40 ± 0.45
Tagliabue et al. (23)	Adults (23)	17.70 ± 2.00	27.10 ± 5.01	77.40 ± 11.30	0.76 ± 0.28	0.39 ± 0.30
Armstrong et al. (24)	Adults (13)	19.88 ± 3.14	31.12 ± 6.80	80.60 ± 14.70	0.74 ± 0.36	0.34 ± 0.37
De Lorenzo et al. (12)	Adults (14)	18.34 ± 2.04	27.13 ± 2.63	74.80 ± 8.83	0.74 ± 0.23	0.36 ± 0.23
Siconolfi et al. (25)	Adults (23)	16.00 ± 3.40	20.80 ± 8.51	69.20 ± 14.00	0.76 ± 0.41	0.44 ± 0.47
Aloia et al. (26)	Adults (200)	13.20 ± 1.70	18.50 ± 2.80	65.50 ± 9.40	0.79 ± 0.28	0.49 ± 0.29
Ellis and Wong (27)	Boys (248)	13.20 ± 6.10	17.50 ± 9.30	47.00 ± 24.30	0.71 ± 1.02	0.31 ± 1.02
	Girls (221)	11.30 ± 4.40	12.00 ± 4.60	47.70 ± 20.60	0.75 ± 0.85	0.49 ± 0.84
Maw et al. (28)	Adult athletes (7)	20.32 ± 0.63	30.85 ± 1.27	78.02 ± 8.61	0.73 ± 0.20	0.31 ± 0.17
Fellmann et al. (29)	Adult athletes (9)	15.80 ± 0.70	25.80 ± 0.80	68.10 ± 2.30	0.76 ± 0.07	0.36 ± 0.07
Gudivaka et al. (30)	Adults (14)	15.70 ± 3.20	28.50 ± 3.70	83.00 ± 14.00	0.80 ± 0.34	0.44 ± 0.33
Lichtenbelt and Fogelholm (31)	Obese women (30)	17.70 ± 1.60	20.50 ± 2.60	80.00 ± 10.50	0.77 ± 0.25	0.50 ± 0.25
Jürimäe et al. (32)	Adult athletes (12)	23.50 ± 2.20	25.50 ± 2.50	82.00 ± 10.80	0.70 ± 0.25	0.37 ± 0.24
Ritz (33)	Adults (35)	18.30 ± 0.50	23.10 ± 0.70	70.30 ± 1.50	0.73 ± 0.04	0.38 ± 0.05
	Elderly subjects (68)	15.10 ± 0.40	18.80 ± 0.50	69.10 ± 1.30	0.77 ± 0.04	0.48 ± 0.04
Buchholz et al. (34)	Adult women (28)	12.50 ± 5.25	18.10 ± 13.30	59.40 ± 17.65	0.78 ± 0.62	0.46 ± 0.76
	Adult men (30)	16.40 ± 6.05	27.40 ± 17.85	74.10 ± 21.20	0.77 ± 0.59	0.38 ± 0.73
Cox-Reijven et al. (35)	Obese adults (10)	21.90 ± 2.40	23.50 ± 4.41	133.30 ± 17.00	0.83 ± 0.25	0.64 ± 0.26
Mean ± SD (Adult)					0.76 ± 0.36	0.42 ± 0.38
Mean ± SD (c_1 and c_2)					0.59 ± 0.37	

Data are reported as means ± SD for the number of subjects indicated within parentheses in the Population column. c_1 = volumetric concentration of the nonconductive material at low frequency; c_2 = volumetric concentration of the nonconductive material at high frequency.

Table 2. Neonate intra- (ICW) and extracellular (ECW) water volumes, weight and volumetric concentration of the nonconductive material.

Study	Population (N)	ECW (liters)	ICW (liters)	Weight (kg)	c_1	c_2
MacLaurin (19)	Term (26)	0.89 ± 0.02	0.87 ± 0.02	2.46 ± 1.01	0.62 ± 0.67	0.25 ± 0.53
Cassady (36)	Term (16)	1.18 ± 0.64	0.99 ± 1.82	3.16 ± 0.52	0.61 ± 0.27	0.28 ± 1.03
Fomon et al. (16)	Term (-)	1.50 ± -	0.96 ± -	3.5 ± -	0.5	0.3
Singui et al. (37)	Term (55)	0.94 ± 0.11	1.15 ± 0.18	2.84 ± 0.23	0.65 ± 0.19	0.23 ± 0.21
Mean ± SD (neonate)					0.61 ± 0.32	0.25 ± 0.44
Mean ± SD (c_1 and c_2)					0.43 ± 0.38	

Data are reported as means ± SD for the number of subjects indicated within parentheses in the Population column. c_1 = volumetric concentration of the nonconductive material at low frequency; c_2 = volumetric concentration of the nonconductive material at high frequency. -, Data not reported.

Therefore, after the changes in the original constant, the final equation for the estimate of ECW in the neonatal population can be written as:

$$ECW = 0.59 \left(\frac{Ht^2 \times Wt^{0.5}}{R_e} \right)^{2/3} \quad (\text{Eq. 10})$$

It should be pointed out that the change in extracellular resistivity (ρ_{ECW}) leads to a correction of $k\rho$, since this constant is related to intra- and extracellular resistivities ($k\rho = \rho_{ICW}/\rho_{ECW}$). In this way, the neonatal $k\rho$ can be obtained from its ratio with the $k\rho$ for adults.

$$\frac{k\rho_N}{k\rho_A} = \frac{\rho_{ICW_N}/\rho_{ECW_N}}{\rho_{ICW_A}/\rho_{ECW_A}} = \frac{\rho_{ICW_N}}{\rho_{ICW_A}} \times \frac{\rho_{ECW_A}}{\rho_{ECW_N}} \quad (\text{Eq. 11})$$

where subscripts N and A indicate the neonatal and adult values, respectively.

Based on Equation 11, the neonatal $k\rho$ can be calculated by:

$$k\rho_N = k\rho_A \times \frac{\rho_{ICW_N}}{\rho_{ICW_A}} \times \frac{\rho_{ECW_A}}{\rho_{ECW_N}} = 3.8 \times 1.0 \times 0.38 = 1.45 \quad (\text{Eq. 12})$$

where $k\rho_A = 3.8$ was extracted from De Lorenzo et al. (12), $\rho_{ECW_A}/\rho_{ECW_N} = 41/107 = 0.38$ (based on De Lorenzo et al. (12) and Equation 8, respectively), and $\rho_{ICW_N}/\rho_{ICW_A}$ was approximated by 1.00, since the intracellular concentration of potassium (the major intracellular ion) is equal in adults and neonates (17).

System calibration

All hardware and the software parts of the system used to estimate the bioelectrical impedance parameters were calibrated using 16 electric models (phantoms) like the one illustrated in Figure 1. The values of the electric components (R_i , R_e , C_m , and C_e) for each phantom were designed to correspond to values expected for neonates (3,18). The true values of the electric model components were inspected with a digital multimeter 3 $\frac{3}{4}$ digit - TEK DMM 254 (Tektronix Inc.,

Beaverton, OR, USA) with an error lower than 0.5 Ω for values of less than 999 Ω , and an error lower than 5 Ω for values greater than 1 k Ω . The root mean square error (RMSE) in the estimation of impedance parameters was obtained by Equation 13:

$$RMSE = \sqrt{\frac{\sum_{i=1}^n (x - y)^2}{N - 2}} \quad (\text{Eq. 13})$$

where X is the real value, Y is the estimated value and N is the number of tests ($N = 16$).

Subjects of the clinical study

A clinical study was conducted in which bioelectrical impedance and anthropometric measurements were performed in 30 full-term neonates (38.9 ± 1.4 months of gestational age) of both genders. Measurements were performed at four different times in each neonate: the first 24 h, 48 h, 10 days, and 1 month. Neonates with any pathology that might change the intra- and/or extracellular volume compartments (renal dysfunction, congestive heart failure, sepsis, and dehydration) were excluded from the study. The study was approved by the Scientific Ethics Committee of the Central Hospital of the Military Police, Rio de Janeiro, RJ, Brazil, and informed consent was obtained from the parents of the neonates.

Bioelectrical impedance and anthropometric measurements

A digital scale (Urano[®], Vila Rosa, Canoas, RS, Brazil) was used to measure the weight of each neonate to the nearest 0.005 kg. The height was measured to the nearest centimeter with an infantometer. Bioelectrical impedance measurements were performed using Ag/AgCl disposable adhesive electrodes (3M Red Dot 2258-3 - neonatal, São Paulo, SP, Brazil). Electrodes were placed on the pisiform prominence of the wrist and between the lateral and medial malleoli at the ankle. The stratum cor-

neum was removed by the standard procedure of 10 wipes with gauze and alcohol in order to avoid difference in bioelectrical impedance measurements.

The neonate was positioned in dorsal decubitus and data acquisition was performed when the newborn was quiet. If necessary, a person using latex gloves held the neonate. All acquisitions were performed before breast-feeding.

Statistical analysis

In addition to the evaluation of the estimation errors of the impedance parameters, the reliability in the measures of the resistive parameters was performed by ANOVA repeated measures, i.e., the intra-class correlation coefficient (R).

Data are reported as means ± SD for each of the four acquisition ages. Significant changes in each variable (R_i , R_e , R_{inf} , TBW, ICW, ECW, and weight) between the four periods were determined by the univariate repeated measures test (within-subjects factor) with four levels (ANOVA method). The level of significance was set at 5% in all analyses. The Pearson correlation coefficient (r) was calculated to determine the extent to which values of two variables are linearly related to each other. It should be noted that r^2 (coefficient of

determination) indicates the proportion of common variation in the two variables. Thus, the variables were considered to show a strong correlation when the proportion of common variation was at least 50%, which implies r values higher than 0.7. However, the interpretation depends on statistical tests, which provide a P value. $P < 0.05$ was taken to be statistically significant.

Results

Results from the calibration of the acquisition system and of the software used to estimate the bioelectrical impedance parameters are presented in Table 3, together with the respective RMSE.

The values of the bioelectrical impedance parameters (R_{inf} , R_e , and R_i) for the neonatal group studied are represented by the box plots in Figure 2.

Table 3. Estimated mean error of bioelectrical impedance parameters.

	R_e	R_i	C_m	C_e
RMSE (Ω or nF)	141.03	239.87	0.26	0.79
RMSE (%)	9.22	10.76	29.36	7.62
Mean RMSE (%)	14.24			

Data are reported as absolute and percentile values; see text for more details. RMSE = root mean square error; R_e = extracellular resistance; R_i = intracellular resistance; C_m = membrane capacitance; C_e = electrode capacitance.

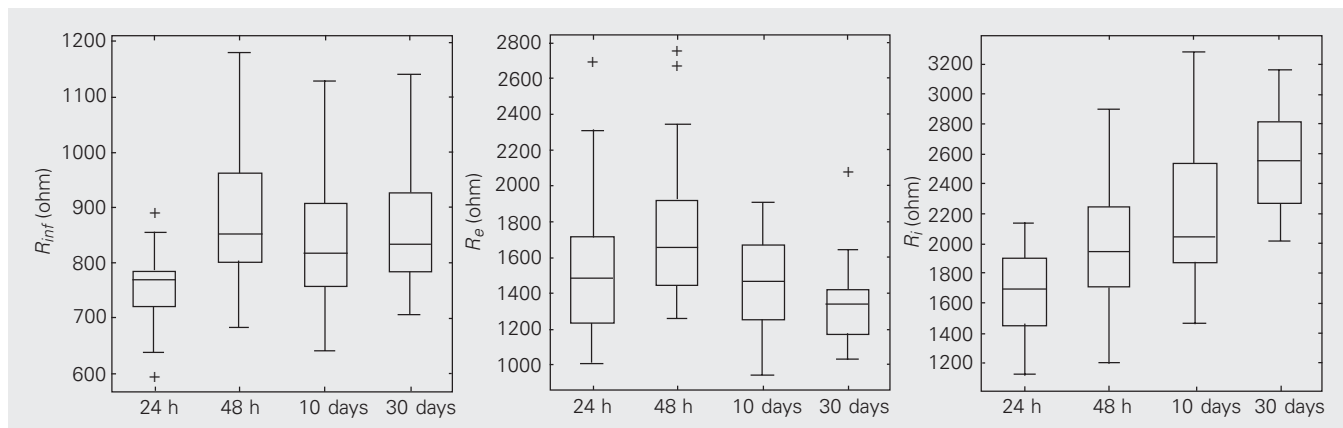

Figure 2. Box plot representation of extracellular resistance (R_e), intracellular resistance (R_i) and the parallel association between R_e and R_i (R_{inf}) at the four ages observed. The bottom of the box marks the 25th percentile, the median line the 50th percentile, and the top of the box the 75th percentile. The bottom of the vertical line indicates the 5th percentile and the top the 95th percentile. The symbols at the top and bottom indicate outlying data points.

Although an increase in all resistive parameters was observed up to the 48th hour, during the period between 48 h and 10 days of age we observed a statistically significant reduction in R_e , a nonsignificant decrease in R_{inf} , and a statistically significant increase in R_i . The same behavior was observed between the 10th day and 1st month, indicating a trend to a reduction in R_e and to an increase in R_i .

Figures 3 and 4 present the box plots for the body composition values (weight, TBW, ECW and ICW) estimated by Equations 7 (ICW) and 10 (ECW).

If the behavior of the resistive parameters described above is correlated with body fluid volumes, a reduction in intracellular volume and an increase in extracellular volume can be expected. This interpretation would not be possible if TBW were simply estimated from the evolution of body weight. Figure 3

shows that between the 24th and 48th hour of age the neonates lost weight (154 ± 78 g, $P < 0.05$), whereas they showed a significant weight gain at 10 days and 1 month (333 ± 151 and 1077 ± 434 g, respectively).

As mentioned before, Equations 7 (ICW) and 10 (ECW), as well as the sum of these two volumes (i.e., TBW), were used to estimate neonatal volumes. It can be seen (Figure 4) that between the 24th and 48th hour of age, statistically significant reductions in TBW, ECW, and ICW were estimated. The reduction in TBW was strongly correlated ($r = 0.76$) with the reduction in body weight observed by the 48th hour of age. Around the 10th day of age, significant increases in TBW and in ECW were observed, but no significant decrease in ICW was detected. During the period between the 10th day and the 1st month of age, TBW and ECW volumes showed a statistically significant increase, while the intracellular volume remained unchanged. The statistical differences between these parameters are shown in Table 4.

The changes in body fluid volumes are more easily appreciated when they are shown as a fraction of body weight. Table 5 presents these fractions from the 24th hour to the 1st month of age. TBW was reduced from 68% (24th hour of age) to 54% (1st month of age). The ECW did not change in a statistically significant manner, remaining at

Figure 3. Box plot representation of weight at the four neonatal ages observed. The box plot form is identified in the legend to Figure 2.

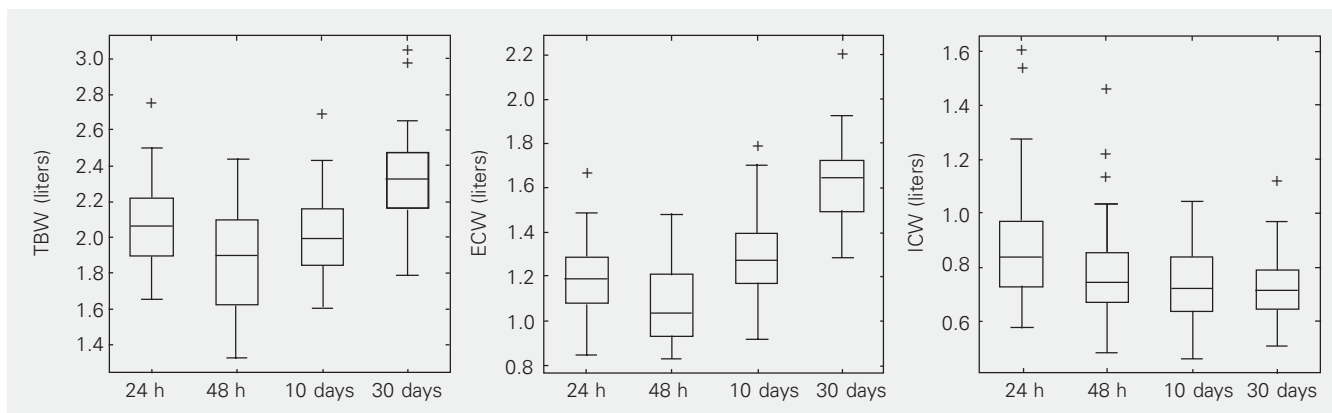
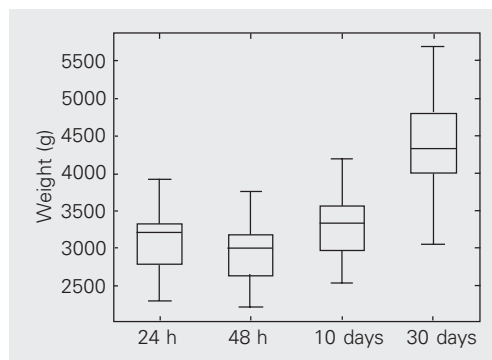

Figure 4. Box plot representation of total body water (TBW), extracellular water (ECW) and intracellular water (ICW) at the four neonatal ages. The box plot form is identified in the legend to Figure 2. Each symbol at the top is an outlying data point.

approximately 37% of body weight, while the intracellular volume was reduced with statistical significance from 29% (24th hour of age) to 17% (1st month of age). These data indicate that during the 1st month of age, the intracellular compartment was the major site responsible for the TBW loss by a transfer mechanism to the extracellular compartment. This interpretation is in agreement with MacLaurin (19), who indicated that during the first 3 days of age a relative ECW increase is observed due to the result of a water shift from the intracellular compartment. This fact is supposed to be correlated with the neonatal renal physiology, because renal inefficiency would result in an increase of extracellular solute concentration and in alterations of intracellular volume.

The analysis of the percentages of intra- and extracellular volumes regarding TBW (Table 5) indicates that the extracellular volume is higher than the intracellular volume, and that the difference between these two volumes increases from the 24th hour to the 1st month of age. Table 5 also shows the fractional composition of TBW, an important index for the determination of normal neonatal maturation (20).

Pearson linear correlation coefficients (r) between several variables during the four periods studied can be seen in Table 6. The extracellular resistance (R_e), which is used to estimate ECW (Equation 10), exhibited a significant correlation ($r > 0.74$) with the value of this compartment at the first three ages of measurement. Intracellular resistance (R_i), which is used to estimate ICW (equation 7), also showed a strong correlation ($r > 0.80$) with ICW during the same period. These facts indicate that the body volume estimates strongly depend on the measurement of these resistive parameters.

The estimation of fluid volumes (TBW, ECW and ICW) from BIS parameters is dependent on factors such as the data acquisition/analysis system, the skin cleaning process, electrode placement, and neonate han-

dling, among others. Considering all the other factors to be adequate, the estimation errors of these fluid volumes were evaluated from the standard error of the estimate of the resistive BIS parameters (R_i and R_e). A com-

Table 4. Significant differences determined by ANOVA of the bioelectrical impedance and body composition parameters at the times of measurement.

	1-2 days	2-10 days	10-30 days	1-10 days	1-30 days
R_{inf}	H ₁	H ₀	H ₀	H ₁	H ₁
R_i	H ₁	H ₁	H ₁	H ₁	H ₁
R_e	H ₁	H ₁	H ₁	H ₀	H ₁
Weight	H ₁	H ₁	H ₁	H ₁	H ₁
TBW	H ₁	H ₁	H ₁	H ₁	H ₁
ICW	H ₁	H ₀	H ₀	H ₁	H ₁
ECW	H ₁	H ₁	H ₁	H ₁	H ₁

H₀ = Null hypothesis (no change); H₁ = rejection of the null hypothesis; R_e = extracellular resistance; R_i = intracellular resistance; R_{inf} = parallel association between R_e and R_i ; TBW = total body water; ICW = intracellular water; ECW = extracellular water.

Table 5. Changes in total body (TBW), intracellular (ICW) and extracellular (ECW) water during the first month of age.

	24 h	48 h	10 days	1 month
TBW/weight (%)	68 ± 4	63 ± 6	62 ± 6	54 ± 6
ECW/weight (%)	39 ± 6	37 ± 5	40 ± 5	37 ± 5
ICW/weight (%)	29 ± 6	27 ± 6	22 ± 4	17 ± 3
ECW/TBW (%)	57 ± 9	58 ± 7	64 ± 6	69 ± 4
ICW/TBW (%)	42 ± 9	42 ± 7	36 ± 6	31 ± 4

Data are reported as means ± SD of % of body volume of TBW, ECW and ICW per neonate weight or as the ratio of ECW and ICW to TBW reported in percent.

Table 6. Pearson linear correlation coefficients (r) between electric parameters (R_i and R_e) and body composition (weight, TBW, ICW and ECW) data for neonates.

	24 h	48 h	10 days	1 month
TBW/weight	0.90	0.76	0.69	0.65
ICW/weight	0.66	0.58	0.21*	0.44
ECW/weight	0.30*	0.45	0.68	0.58
TBW/ICW	0.64	0.73	0.51	0.64
TBW/ECW	0.44	0.64	0.86	0.90
ICW/(1/ R_i)	-0.90	-0.85	-0.80	-0.62
ECW/(1/ R_e)	-0.77	-0.74	-0.76	-0.41

TBW = total body water; ICW = intracellular water; ECW = extracellular water; R_e = extracellular resistance; R_i = intracellular resistance. *P > 0.05, not statistically significant.

parison of these values with the errors reported in the literature can be seen in Table 7, which shows that the errors reported in the present paper are lower for all parameters than those reported for neonates, children and adults in seven studies.

Discussion

The aim of evaluating the system calibration was to calculate the estimation error in the determination of the bioelectrical impedance parameters. Although the total mean estimation error was 14.24%, the major component of error was due to the estimation of C_m (29.36%). The latter error could be attributed to some characteristics of the acquisition system, such as the cable lengths and other forms of stray capacitance. Since only R_e and R_i are used to calculate body volumes, and the estimation errors associated with these resistances were significantly lower (9.22 and 10.76%, respectively), the bioelectrical impedance values can be considered precise within a 10% error when compared to real values. Evaluation of the instrument reliability showed an intraclass correlation coefficient of 0.75 for R_e and 0.8 for R_i , with values of 0.75 or higher being usually accepted as a good indicator of stability.

As mentioned before, the above precision in the measures of the resistive parameters leads to estimation errors in TBW, ECW and ICW of 3.1, 2.1 and 4.7%, respec-

tively (Table 7), similar to those reported in the literature. It should be pointed out that the data shown in Figure 4 present an average coefficient of variation of 0.17, indicating a coherent and homogeneous data set (< 0.25).

The behavior of the resistances (R_{inf} , R_i , and R_e) agreed with those physiologically expected for the different ages tested. Between the 24th and 48th hour of age all resistive parameters increased in a statistically significant manner. Kushner et al. (21) reported that, normally, if the fluid resistivity does not change, the resistance changes are expected to be proportional to the inverse of the changes in fluid volume. Thus, generally, positive changes in resistance can be interpreted as reductions in such volume, and vice-versa. Consequently, the positive changes in the resistive parameters observed here between the 24th and 48th hour of age seem to be correctly correlated with the decrease observed in body weight.

The results presented in Table 6 indicate that TBW was significantly correlated with body weight, but intra- and extracellular volumes did not show the same behavior. It was also observed that the significant correlation between TBW and body weight decreased with age. This fact is probably caused by changes in the neonate's body composition since, a decrease of neonatal body water occurs during this period, as well as an increase in neonatal fat mass. These results indicate that TBW can be estimated by body weight, as normally done in the literature, although the ECW and ICW volumes cannot be determined only by anthropometric measurements.

The higher correlation between TBW and ICW observed in the first two periods of measurement when compared with the correlation between TBW and ECW suggests that the reduction of TBW during the first 48 h of age was probably caused by the decrease in intracellular volume. This behavior can be analogously attributed to the higher

Table 7. Standard error of the estimate (SEE) and percent SEE of mean dilution of body volumes.

Studies	Population	TBW (liters)	ECW (liters)	ICW (liters)
Present study	Neonate	0.065 (3.1%)	0.027 (2.1%)	0.037 (4.7%)
Mayfield et al. (3)	Neonate	0.088 (6.8%)	0.057 (7.7%)	-
Lingwood et al. (6)	Neonate	-	0.058 (8.5%)	-
Goran et al. (8)	Children	0.63 (5.4%)	-	-
Tagliabue et al. (23)	Adult	1.51 (4.0%)	0.70 (4.6%)	-
Cornish et al. (22)	Adult	2.1 (5.2%)	1.8 (10.0%)	-
De Lorenzo et al. (12)	Adult	1.33 (3.2%)	0.90 (4.3%)	1.69 (8.4%)
Earthman et al. (38)	Adult	2.03 (5.0%)	1.49 (8.8%)	2.06 (8.8%)

-, Not available.

correlation found between TBW and ECW at the last two periods of measurement, indicating that the increase in TBW after the 10th day of age can be attributed to an increase in extracellular volume. These data seem to confirm the idea that ICW shifts to the ECW compartment.

Although no gold standard was used for validation of the method, the observed values and changes in TBW, ECW, and ICW were coherent with literature data, showing that the proposed equations provided estimates of these volumes close to those expected for normal term neonates.

The estimation of these body volumes

can be of help for better neonatal care, especially in the analysis of diseases in which the ECW and/or ICW can be modified without changes in TBW.

In the present study we developed new equations to assess fluid volumes (TBW, ICW and ECW) in neonates from bioelectrical impedance measurements. These new equations can be considered to be extensions of the ones developed by De Lorenzo et al. (12). In conclusion, the assessment of body fluid by a noninvasive, inexpensive and fast method, BIS, can contribute to increasing the quality of the neonatal care.

References

1. El-Dahr SS & Chevalier RL (1990). Special needs of the newborn infant in fluid therapy. *Pediatric Clinics of North America*, 37: 323-336.
2. Thomasset A (1962). Bioelectrical properties of tissue impedance measurements. *Lyon Medical*, 207: 107-118.
3. Mayfield SR, Uauy R & Waidelich D (1991). Body composition of low-birth-weight infants determined by using bioelectrical resistance and reactance. *American Journal of Clinical Nutrition*, 54: 296-303.
4. Kushner RF & Schoeller DA (1986). Estimation of total body water by bioelectrical impedance analysis. *American Journal of Clinical Nutrition*, 44: 417-424.
5. Lukaski HC, Johnson PE, Bolonchuk WW & Lykken GI (1985). Assessment of fat free mass using bioelectric impedance measurements of the human body. *American Journal of Clinical Nutrition*, 41: 810-817.
6. Lingwood BE, Coghlan JP, Ward LC, Charles BG & Colditz PB (2000). Measurement of extracellular fluid volume in the neonate using multiple frequency bio-impedance analysis. *Physiological Measurement*, 21: 251-262.
7. Hoffer EC, Meador CK & Simpson DC (1969). Correlation of whole-body impedance with total water volume. *Journal of Applied Physiology*, 27: 531-534.
8. Goran MI, Kaskoun MC, Carpenter WH, Poehlman ET, Ravussin E & Fontvieille A (1993). Estimating body composition of young children by using bioelectrical resistance. *Journal of Applied Physiology*, 75: 1776-1780.
9. Tang W, Ridout D & Modi N (1997). Assessment of total body water using bioelectrical impedance analysis in neonates receiving intensive care. *Archives of Disease in Childhood*, 77: F123-F126.
10. Wilson DC, Baird T, Scrimgeour C, Halliday H, Reid M & McClure G (1993). Total body water measurement by bioelectrical impedance in the extremely low birth weight infant. *Basic Life Sciences*, 60: 185-188.
11. Neves CEB & Souza MN (2000). A method for bio-electrical impedance analysis based on a step-voltage response. *Physiological Measurement*, 21: 395-408.
12. De Lorenzo A, Andreoli A, Matthie J & Withers P (1997). Predicting body cell mass with bioelectrical impedance by using theoretical methods: a technological review. *Journal of Applied Physiology*, 82: 1542-1558.
13. Cornish BH, Thomas BJ & Ward LC (1998). Effect of temperature and sweating on bioelectrical impedance measurements. *Applied Radiation and Isotopes*, 49: 475-476.
14. Heimler R, Doumas BT, Jendrzeyczak BM, Nemeth PB, Hoffman RG & Nelin LD (1993). Relationship between nutrition, weight change, and fluid compartments in preterm infants during the first week of life. *Journal of Pediatrics*, 122: 110-114.
15. Bauer K, Bovermann G, Roithmaier A, Götz M, Präiss A & Versmold HT (1990). Body composition, nutrition, and fluid balance during the first two weeks of life in preterm neonates weighing less than 1500 grams. *Journal of Pediatrics*, 118: 615-620.
16. Fomon SJ, Haschke F, Ziegler EE & Nelson SE (1982). Body composition of reference children from birth to age 10 years. *American Journal of Clinical Nutrition*, 35: 1169-1175.
17. Cristian JR & Talso PJ (1959). Exchangeable potassium in normal full-term newborn infants. *Pediatrics*, 23: 63-66.
18. Raghavan CV, Super DM, Chatburn RL, Savin SM, Fanaroff AA & Kalhan SC (1998). Estimation of total body water in very-low-birth-weight infants by using anthropometry with and without bioelectrical impedance and H₂[¹⁸O]. *American Journal of Clinical Nutrition*, 68: 668-674.
19. MacLaurin JC (1965). Changes in body water distribution during the first two weeks of life. *Archives of Disease in Childhood*, 41: 286-291.
20. Cheek DB (1961). Extracellular volume: its structure and measurement and the influence of age and disease. *Medical Progress*, 58: 103-125.
21. Kushner RF, Schoeller DA, Fjeld CR & Danford L (1992). Is the impedance index (ht²/R) significant in predicting total body water? *American Journal of Clinical Nutrition*, 56: 835-839.
22. Cornish BH, Ward C, Thomas BJ, Jebb SA & Elia M (1996). Evalua-

- tion of multiple frequency bioelectrical impedance and Cole-Cole analysis for the assessment of body water volumes in healthy humans. *European Journal of Clinical Nutrition*, 50: 159-164.
23. Tagliabue A, Cena H & Deurenberg P (1996). Comparative study of the relationship between multi-frequency impedance and body water compartments in two European populations. *British Journal of Nutrition*, 75: 11-19.
 24. Armstrong LE, Kenefick RW, Castellani JW, Riebe D, Kavouras SA, Kuznicki JT & Maresh CM (1998). Bioelectrical impedance spectroscopy technique: intra-, extracellular, and total body water. *Medicine and Science in Sports and Exercise*, 29: 1657-1663.
 25. Siconolfi SF, Gretebeck RJ, Wong WW, Pietrzyk RA & Suire SS (1997). Assessing total body and extracellular water from bioelectrical response spectroscopy. *Journal of Applied Physiology*, 82: 704-710.
 26. Aloia JF, Vaswani A, Flaster E & Ma R (1998). Relationship of body water compartments to age, race, and fat-free mass. *Journal of Laboratory and Clinical Medicine*, 132: 483-490.
 27. Ellis KJ & Wong WW (1998). Human hydrometry: comparison of multifrequency bioelectrical impedance with 2H₂O and bromide dilution. *Journal of Applied Physiology*, 85: 1056-1062.
 28. Maw GJ, Mackenzie IL & Taylor NAS (1998). Human body-fluid distribution during exercise in hot, temperate and cool environments. *Acta Physiologica Scandinavica*, 163: 297-304.
 29. Fellmann N, Ritz P, Ribeyre J, Beaufrère B, Delaître M & Coudert J (1999). Intracellular hyperhydration induced by a 7-day endurance race. *European Journal of Applied Physiology*, 80: 353-359.
 30. Gudivaka R, Schoeller RF & Bolt MJG (1999). Single- and multifrequency models for bioelectrical impedance analysis of body water compartments. *Journal of Applied Physiology*, 87: 1087-1096.
 31. Lichtenbelt WDVM & Fogelholm M (1999). Increased extracellular water compartment, relative to intracellular water compartment, after weight reduction. *Journal of Applied Physiology*, 87: 294-298.
 32. Jürimäe J, Jürimäe T & Pihl E (2000). Changes in body fluids during endurance rowing training. *Annals of the New York Academy of Sciences*, 904: 353-358.
 33. Ritz P (2000). Body water spaces and cellular hydration during healthy aging. *Annals of the New York Academy of Sciences*, 904: 474-483.
 34. Buchholz AC, Rafii M & Pencharz PB (2001). Is resting metabolic rate different between men and women? *British Journal of Nutrition*, 86: 641-646.
 35. Cox-Reijven PL, Kreel B & Soeters PB (2002). Accuracy of bioelectrical impedance spectroscopy in measuring changes in body composition during severe weight loss. *Journal of Parenteral and Enteral Nutrition*, 26: 120-127.
 36. Cassady G (1971). Effect of cesarean section on neonatal body water spaces. *New England Journal of Medicine*, 285: 887-891.
 37. Singui SC, Sood V, Bhakoo ON, Ganguly NK & Kaur A (1995). Composition of postnatal weight loss & subsequent gain in preterm infants. *Indian Journal of Medical Research*, 101: 157-162.
 38. Earthman CP, Matthie JR, Reid PM, Harper IT, Ravussin E & Howell WH (2000). A comparison of bioimpedance methods for detection of body cell mass change in HIV infection. *Journal of Applied Physiology*, 88: 944-956.