

Enio Pedone Bandarra Filho

bandarra@mecanica.ufu.br
Federal University of Uberlandia
Faculty of Mechanical Engineering
38400-902 Uberlandia, MG, Brazil

Francisco E. Moreno Garcia

Francisco_moreno78@hotmail.com
University Francisco de Paula Santander
Faculty of Engineering
Cucuta, NS, Colombia

Oscar S. Hernandez Mendoza

oscarhernandez@mecanica.ufu.br
Federal University of Uberlandia
Faculty of Mechanical Engineering
38400-902 Uberlandia, MG, Brazil

Application of Adaptive Control in a Refrigeration System to Improve Performance

This paper reports an experimental investigation using adaptive control in a refrigeration system. This system is composed basically of a semi-hermetic compressor, concentric tubes heat exchangers, the condenser and evaporator, and thermostatic expansion valve (TXV). The refrigerant used in the refrigeration system was the HCFC-22 and also an AC frequency inverter was used to control the speed of the compressor. The temperatures were measured by PT-100 sensors and the pressures using piezoresistive pressure transducers. Data acquisition was implemented using the Labview software. An electronic card with analogical signal output was also used. These analogical signals were converted into digital through a Programmable Logic Controller (PLC) and then sent to the computer through a PC serial port. Tests were performed with a variable speed compressor in the range from 30 to 70 Hz and the experimental results showed that the highest performance (COP) was attained by working in the range of 50 Hz, using adaptive fuzzy control.

Keywords: Refrigeration system, control, fuzzy, adaptive, coefficient of performance.

Introduction

Refrigeration equipments, operating with 8 or more hours of daily use, are inefficient energy saving due to design faults, bad installations, and lack of maintenance and are susceptible to fail up operation frequently. The energy saving is reached through the optimization of the equipment performance with the use of control techniques in these systems. Important aspects, such as energy cost for residential, commercial and, mainly, industrial places using strategies and new technologies with the objective to improve the performance in each installation, through the monitoring system performance, is a fundamental tool to automate and to optimize refrigeration and air conditioning systems. In future, the process will grow with the use of integrated equipments, generating an improved performance in the process and a decrease in faults. On the other hand, the inefficient use of electric energy supplied to the compressors is considered as an indirect contribution to the emission of greenhouse gases. Therefore, by improving the energy conversion efficiency, using the control techniques, these emissions can be reduced. The present work is focused on the control application and evaluation of a chiller, using a variable speed compressor.

Nomenclature

CMRR = Common Mode Radio
COP = coefficient of performance
 $e(k)$ = inlet error of the adaptive fuzzy control
FET = field effect transistor
 k = refer to each instant time used
KKV = adaptive mechanism of internal factor
KV = sensibility scale factor
 \dot{m}_{R22} = refrigerant mass flow rate, [kg/s]
PID = proportional integral derivative controller
PLC = Programmable Logic Controller
P1 = suction pressure of the compressor, [kPa]
P2 = discharge pressure of the compressor, [kPa]

P3 = condensation pressure, [kPa]
P4 = pressure measured after the thermostatic expansion valve, [kPa]
 \dot{Q}_{ev} = refrigeration capacity, [kW]
SISO = traditional control for only one entrance and only one exit
 S_p = $r(k)$ = Setpoint
 T_{cd} = condensation temperature, [°C]
 T_{ev} = evaporation temperature, [°C]
 T_1 = outlet temperature of the refrigerant in the evaporator, [°C]
 T_5 = $y(k)$ = Exit water temperature in the evaporator, [°C]
 T_8 = inlet water temperature in the evaporator, [°C]
TXV = thermostatic expansion valve
 u_c = exit signal of the fuzzy adaptive control
 $|\bar{u}_c|$ = mean absolute exit signal of the fuzzy adaptive control
 \dot{W} = power consumption, [kW]

Greek Symbols

ΔP = pressure drop, Pa
 $\Delta e(k)$ = change of the inlet error of the adaptive fuzzy control
 $|\Delta \bar{e}|$ = mean absolute change of the inlet error of the adaptive fuzzy control
 Δt = refer to time period used, [s]
 ΔT_{sc} = degree of subcooling, [°C]
 ΔT_{sh} = degree of superheating, [°C]

Literature Survey

In refrigeration systems, the control technique used is an important tool in terms of thermal performance, varying the operational conditions of the compressor as a function of a prescribed time. In constant speed equipment, when the temperature sensors indicates that the temperature is close to the high set point, normally, the On-Off thermostat goes to the On position and the compressor is started up. And it remains in operation until the sensor indicates the lower temperature set value, when the thermostat changes to the Off position and the compressor is switched off. Thus, the thermostat acts in the system feedback and

the compressor activation, and must be sized to withstand high electric current and voltage. However, these equipments do not present the best energetic performance due to their own operational characteristics.

Nguyen et al. (1982) studied the degradation of the performance in different configurations of air conditioning systems due to the modulation *On-Off* and concluded that the intermittent operation of the system causes other inconveniences, such as the additional energy consumption to start up the compressor. Lida et al. (1982) conducted an experimental study in a refrigeration system and the main conclusion was that the practical limits for the compressor speed variation should remain within the range of 25 and 75 Hertz. Results indicated improvements of the order of 30%, regarding the energy efficiency with the variable speed compressor, if compared to a fixed speed compressor. O'Neal and Katipamula (1991) developed a first order model validated experimentally for air conditioning systems and heat pumps. Results showed a reduction in the efficiency of these systems, when "On" and "Off" positions were switched off in small time intervals. New technologies, such as frequency inverter, facilitate the implementation of more efficient systems regarding the reduction of the energy consumption in refrigeration systems. Since such systems operate most of the time in transient conditions, a considerable reduction of energy can be reached with the thermal load in low speeds operation of the compressor.

Recent studies have shown improvements in terms of energetic efficiency and reliability of vapor compression systems when using the variable speed compressor to ensure the thermal load control, (Shuangquan, 2004, and Koury et al., 2001). Vargas and Parise (1995) presented a mathematical model for a heat pump with a variable-speed compressor, operating in closed loop by a power law control action or by the traditional *On-Off* basis. The results showed that the closed loop system presented significant energy consumption savings when compared with the *On-Off* system, under the same outdoor ambient temperatures. Aprea et al. (2006) evaluated experimentally the performance of a vapor compression system operating as a chiller and as a heat pump. The experimental results for the scroll compressor presented the best performance due to the easiness of operation with minimum frequencies, 15 Hz, in comparison to the semi-hermetic reciprocating compressor, with a lower frequency limit of 30 Hz. In this range of reduced frequencies, below 30 Hz, the semi-hermetic reciprocating compressor presents considerable vibration and increment of noise, due to inadequate lubrication of the cylinders. Specifically, with regard to the liquid cooling system (chiller), operating with different evaporation temperature set points (7, 11 and 15°C), a significant reduction on energy consumption of 20% was reached with the use of the scroll compressor and the use of the complex PID control system.

In most conventional refrigeration systems, the efficient operation of the thermostatic expansion valve maintains fixed the relation between low and high pressures, therefore this device is not sensitive to thermal load variations.

In the control strategies area, working with a vapor compression system, the fuzzy control strategy has shown a significant evolution in the last few decades, due to its capacity to act in these systems, based only on the knowledge of a specialist to relate all variables of the process. Carvajal (2000), using the fuzzy control with modifier gain, conducted an experimental study in order to maintain the degree of superheating constant and the final result was the stability of the degree of superheating with variations lower than 1°C, even for distinct thermal loads. Da Silva and Silveira Junior (2001) conducted a numerical study, using a fuzzy control based on the oscillation of the condensation temperature in the refrigeration system. The fuzzy control presented variations in the condensation

temperature of 2.4°C and -1.5°C, and after the controller tuning, these variations were reduced to 0.3°C and -0.7°C, respectively.

Kolokotsa et al. (2000) evaluated the simulation level of methods such as fuzzy PID control, fuzzy PD and fuzzy adaptive PD, basically focused on the thermal comfort for Air Conditioning system. They concluded that the better efficiency was achieved when the system worked with fuzzy PD controller, compared with other types, between 25 and 30% of energy consumption savings.

One of the most recent works found, by applying strategies of intelligent control, was conducted by Borja (2006), who developed the control of two distinct parameters in the circuit, the electronic expansion valve and variable speed compressor. Such controls were based on Artificial Neural Network (ANN). In this case, the predictive controller was designed to work simultaneously on two components (valve and compressor), controlling the temperature difference of water that circulates in the evaporator and keeping fixed the degrees of superheating ($> 10^{\circ}\text{C}$) and subcooling ($> 0^{\circ}\text{C}$).

This paper focused on the evaluation and control of the performance in a refrigeration system using fuzzy adaptive techniques, controlling the exit water temperature in the evaporator (thermal load) and compared the results with conventional on-off control.

Experimental Setup

A schematic diagram of the experimental facility used in the present investigation is shown in Fig. 1. This refrigeration system, or simply chiller, was an adaptation from a self-contained air conditioning unit with 17.5 kW of cooling capacity. Refrigerant is pumped from the condenser (concentric tubes) to the coriolis mass flow meter reaching the entrance of the thermostatic expansion valve. Upon leaving the thermostatic expansion valve (TXV), the refrigerant flows through an evaporator (concentric tubes) and then goes back to the compressor. The results reported herein have been obtained in different operation conditions, by varying the compressor speed. Water from a cooling tower was used to condense the refrigerant in the circuit. To simulate the thermal load in the evaporator, heated water was used from a storage tank, very well insulated with an immersed electrical heater of 15 kW, commanded by a *PID* control in a Programmable Logic Controller (*PLC*). The refrigerant used in the system was HCFC-22 (R-22). Also an AC frequency inverter was used to control the compressor speed. The temperatures were measured by PT-100 sensors and pressures were measured by piezoresistive pressure transducers. All these sensors were calibrated before, during and after the tests. The data acquisition system was implemented using the software Labview. An electronic card with analogical signal output was also used. The analogical signals were converted into digital through a Programmable Logic Controller and then sent to the computer through a PC serial port. The accuracy of the calculated parameters was determined according to the procedure suggested by Albernethy and Thompson (1980) with an interval of confidence of 95%. The accuracy of measured and calculated parameters is shown in Table 1. It can be noted that in the Figs. 5 and 7 the Coefficient of Performance accuracy varies from ± 0.06 to ± 0.25 and the Refrigeration Capacity from ± 0.15 to ± 0.16 . The COP upper limit corresponds to the lower frequencies and the higher frequencies are the smallest.

The integrated circuit, INA125AP, characterized by the instrumentation amplifier for high quality that use a Wheatstone Bridge, was used, for the temperature signals from PT100 sensors. In Fig. 2 the schematic diagram of the electronic circuit used for the temperature signals, developed by the authors, is shown. Piezoresistive pressure transducers were used to measure the refrigerant pressure, depicted in Fig. 1. For the pressure signals, it

was used other integrated circuit, INA111, with an instrumentation amplifier type FET-input with high performance. This amplifier type FET-input reduces the noise of the voltage signals. The same circuit, INA111, was also used to process the signals from the coriolis mass flow meter.

Table 1. Measuring accuracy of measurement parameters with confidence interval of 95%.

Parameter	Accuracy
Temperature	±0.15 K
Pressure	±0.30%
Mass flow rate	±0.15%
Power consumption	±0.10 kW

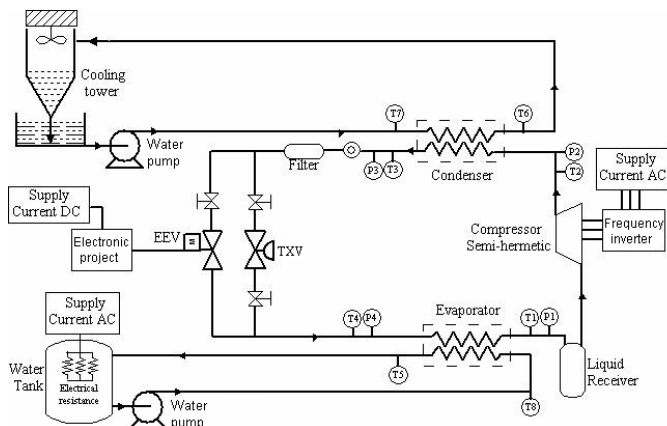

Figure 1. Schematic diagram of the experimental facility used in the present investigation.

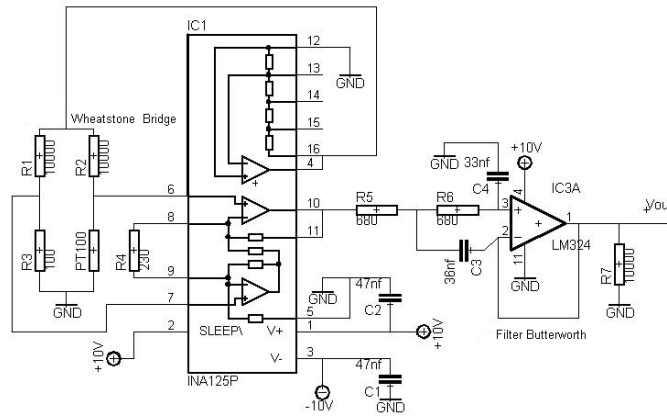

Figure 2. Schematic diagram of the electronic circuit used for the temperature signals.

LabVIEW was used as the graphical programming interface to acquire and integrate the variables such as temperature, pressure and refrigerant mass flow in a supervisory computer. Figure 3 depicts the supervision screen of the system where it is possible to analyze the parameters thermodynamics.

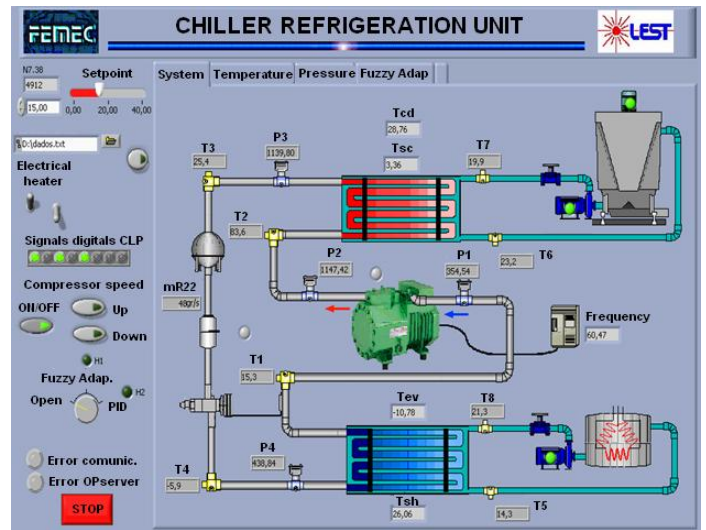

Figure 3. Supervision and command screen of the experimental facility.

Fuzzy Adaptive Control

Most of the present refrigeration processes require a non-linear automatic control, with parameters that depend on the operating conditions, Garcia (2006). To identify these changes and to adjust these new conditions, two new extra components are included in the adaptive fuzzy control. The first component is the monitor of process responsible to detect the changes in the characteristics of the process. This can be done in two ways: by measuring the performance of the system or by estimating, continuously, some parameters of the process. The other component is the adaptive mechanism, which can change the control parameter to improve the performance, based on the outputs of the process. Figure 4 shows the typical adaptive fuzzy control with its components.

The input variables in fuzzy control were evaluated by the error signal, e , and the error change, Δe , defined by the following equations:

$$e(k) = r(k) - y(k) \tag{1}$$

$$\Delta e(k) = \frac{e(k) - e(k-1)}{\Delta t} \tag{2}$$

where, k and Δt refer to each instant and time period used, and $y(k)$ is the temperature signal of the water in the evaporator outlet.

The second step, after the design of the main controller, was the addition of the adaptive mechanism and the monitor of process and this was based on the mean absolute error, $|\Delta \bar{e}|$, and mean absolute control, $|\bar{u}_c|$, observing the last three samples. These parameters were calculated as follow:

$$|\Delta \bar{e}| = \frac{|\Delta e(k)| + |\Delta e(k-2)| + |\Delta e(k-3)|}{3} \tag{3}$$

$$|\bar{u}_c| = \frac{|u_c(k)| + |u_c(k-2)| + |u_c(k-3)|}{3} \tag{4}$$

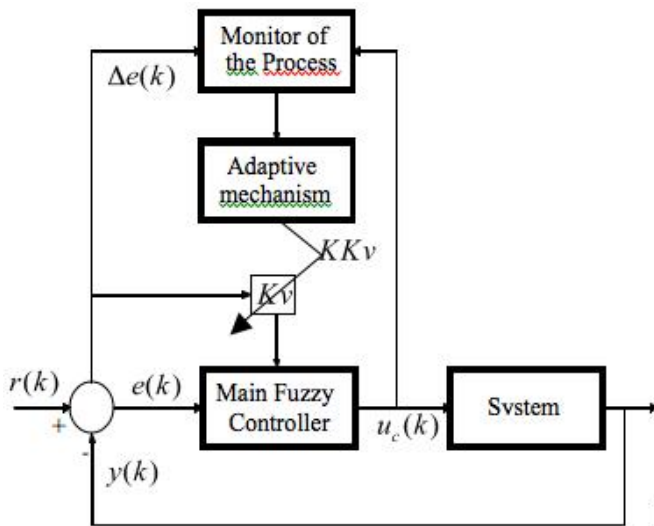
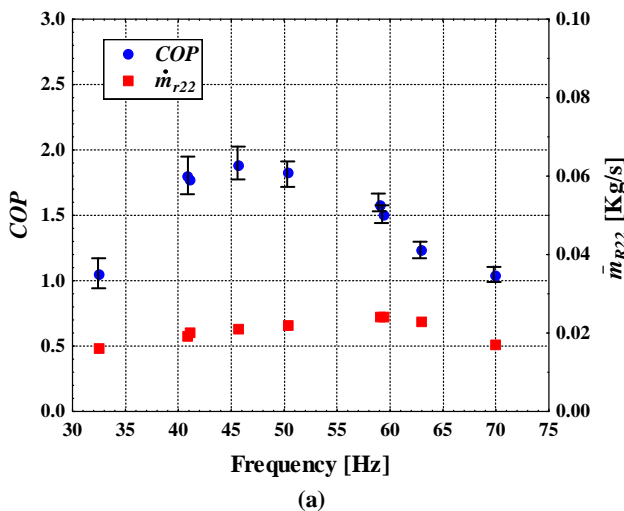

Figure 4. Details of the Fuzzy Adaptive Control.

Analysis of Results

The results reported herein have been obtained in different operation conditions varying the compressor speed in the range from 32 to 70 Hz. Figure 5(a) shows the coefficient of performance, (COP), defined by the relation between the refrigeration capacity and power consumption, and the refrigerant mass flow rate (\dot{m}_{R22}) as a function of the compressor frequency for a refrigerant charge of 2.8 kg. It is important to note that, for 60Hz (nominal frequency), the system does not present the maximum COP, in spite of having the maximum refrigeration capacity (\dot{Q}_{ev}), of the order of 4.25 kW, Fig. 5(b), and a maximum refrigerant mass flow rate (\dot{m}_{R22}) of 0.024 kg/s. It is interesting to emphasize that, above 65 Hz and below 40 Hz, a minimum COP of 1.04 was found, due to reduced values of mass flow rate (\dot{m}_{R22}) 0.016 kg/s. On the other hand, the maximum COP values, within 1.77 and 1.88, were reached in the frequency range of 41 and 50 Hz, respectively, due, mainly, to an optimal refrigeration capacity.



(a)

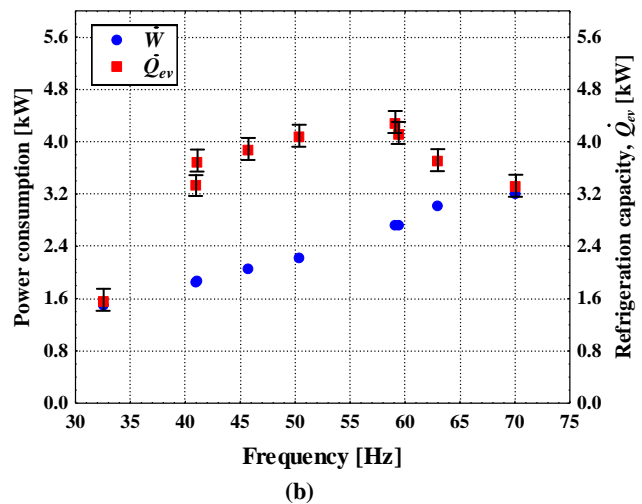

(b)

Figure 5. (a) Coefficient of performance (COP) and mass flow rate (\dot{m}_{R22}); (b) Refrigeration capacity (\dot{Q}_{ev}) and power consumption (\dot{W}) in function of the compressor frequency for 2.8 kg of refrigerant charge in the refrigeration system.

Figures 6(a) and (b) present the degrees of superheating (ΔT_{sh}) and of subcooling temperatures (ΔT_{sc}) and the condensation (T_{cd}) and evaporation temperatures (T_{ev}), respectively. It can be clearly observed that, over the entire frequency range, the degree of subcooling was kept slightly above 0°C and the degree of superheating remained above 15°C. The evaporation and condensation temperatures varied, as expected, in the frequencies above 50 Hz, as seen in Fig. 6(b).

Figures 7 and 8 show the experimental results with a refrigerant charge of 0.5 kg greater than that of the previous tests, totaling 3.3 kg. There was the need to open slightly the thermostatic expansion valve (TXV). The water flow in the evaporator was maintained constant at 0.21 kg/s and the water supply temperature, at 20°C, as previously established.

The behavior of several parameters, such as COP, compression power consumption, refrigeration capacity and refrigerant mass flow rate were obtained and plotted in Fig. 7(a) and Fig. 7(b). It is interesting to observe in Fig. 7(b) that, with the increase of 0.5 kg of refrigerant charge in the system, a considerable increase in the refrigerant mass flow rate, between 0.03 and 0.04 kg/s, was obtained in comparison with the previous case.

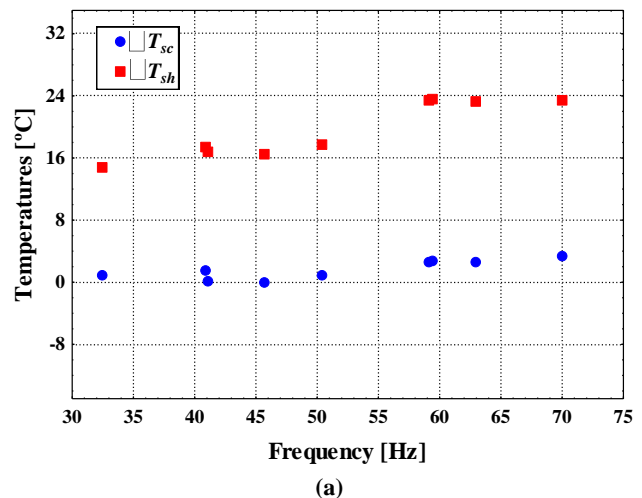

(a)

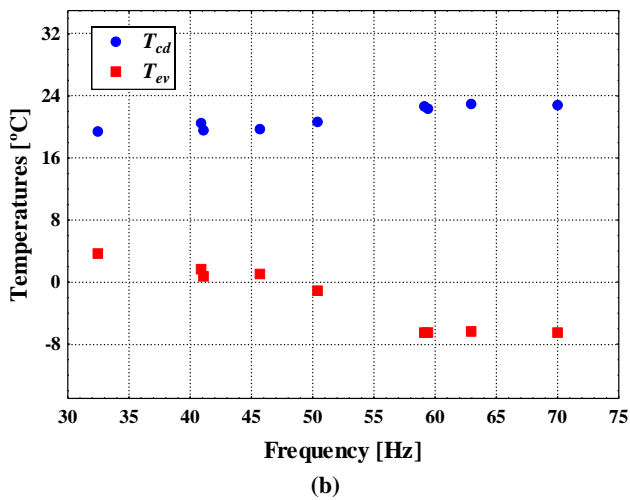

Figure 6. (a) Behavior of subcooling and superheating (ΔT_{sh} , ΔT_{sc}); and (b) condensation and evaporation temperatures (T_{cd} , T_{ev}) in function of the frequency for 2.8 kg of refrigerant charge in the refrigeration system.

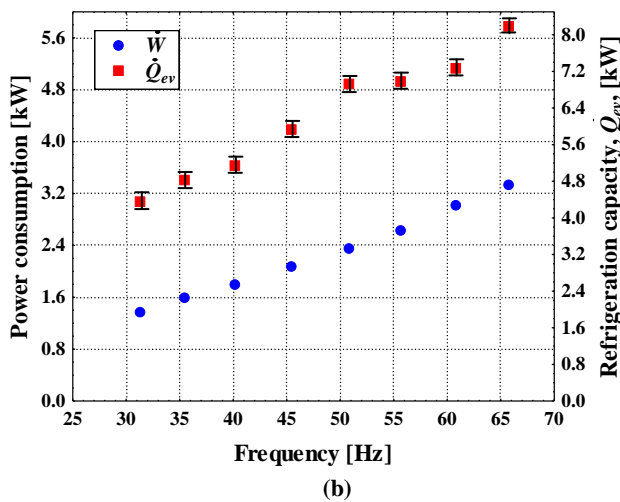
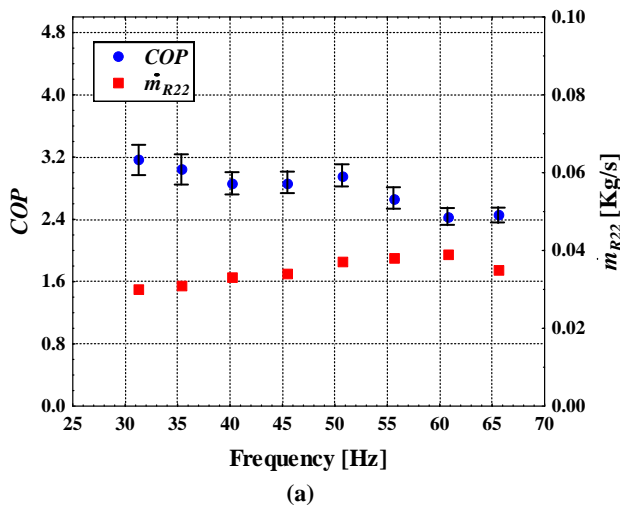

Figure 7. (a) Coefficient of performance (COP) and refrigerant mass flow rate (\dot{m}_{R22}); and (b) refrigeration capacity (\dot{Q}_{ev}) and compressor power consumption (\dot{W}) as a function of the compressor frequency for 3.3 kg of refrigerant charge in the refrigeration system.

Another interesting point in relation to the system performance is that maximum values of COP of 3.2 were observed for frequencies of the order of 30 Hz and not in the nominal frequency of 60 Hz (1750 rpm). As expected, with the increase of refrigerant charge in the system, the refrigeration capacity increased for all frequencies tested, as observed in Fig. 7(b), in comparison with Fig. 5(b).

Figure 8(a) presents the degrees of superheating and subcooling. It can be observed that the degree of subcooling (ΔT_{sc}) was maintained practically constant with frequency and the degree of superheating (ΔT_{sh}) varied in the range between 10 and 20°C. The behavior of condensation and evaporation temperatures is displayed in Fig. 8(b). It is interesting to observe that the condensation temperature increased with frequency and the evaporation temperature decreased related to the difference between the suction pressure and discharge pressure of the compressor.

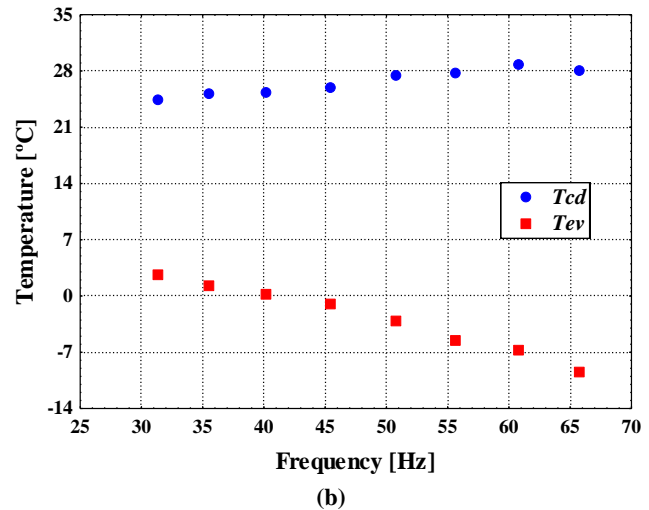
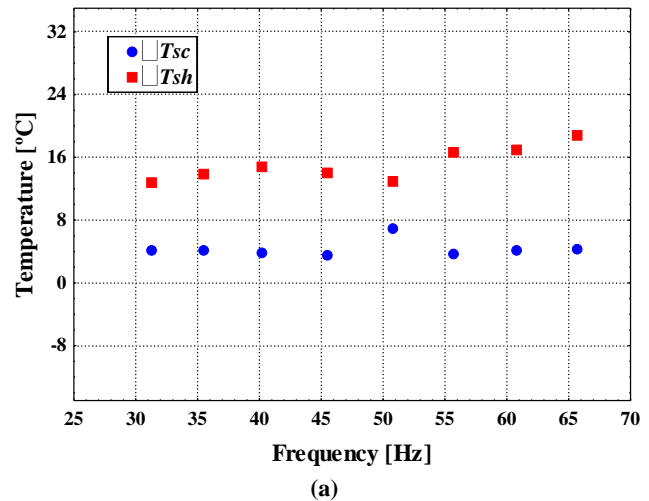

Figure 8. (a) Behavior of subcooling and superheating (ΔT_{sh} , ΔT_{sc}); and (b) condensation and evaporation temperatures (T_{cd} , T_{ev}) as a function of frequency for 3.3 kg of refrigerant charge in the refrigeration system.

In the present work, the controller was used to maintain the exit water temperature in the evaporator ($T5$) fixed, as a function of the water temperature prescribed at the entrance ($T8$), to simulate the thermal load. In order to verify the controller operation, a simple controller, of the *On-Off* type, was included for comparison purposes. The controllers acted in the signal so that the exit water

temperature in the evaporator ($T5$) was maintained around of the reference setpoint, in this case, 13.5°C. The inlet water temperature in the evaporator ($T8$), controlled by an electric heater immersed in water storage tank, was maintained at 22°C. During experiments, compressor power consumption (kW) was also registered, in addition to pressures and temperatures.

It is possible to observe, in Fig. 9, that temperature $T5$ was maintained between 13.4 and 22°C and the inlet water temperature in the evaporator ($T8$) remained near 22°C. Figure 10 shows the behavior of the system pressures when operating with the controller in *On-Off* mode.

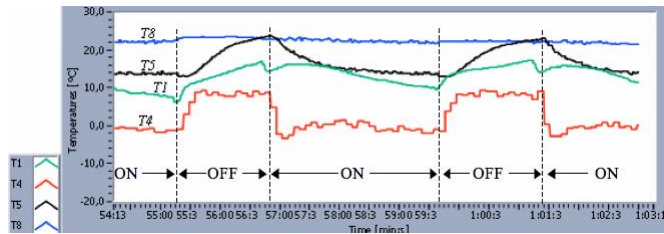

Figure 9. Evolution of the temperatures in the evaporator, applying the *On-Off* control.

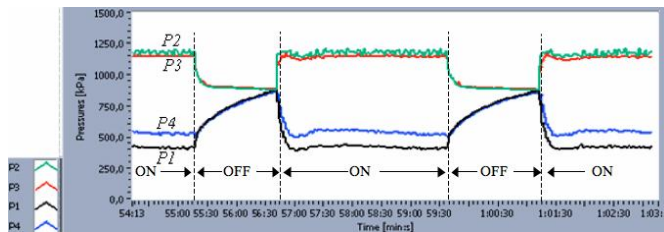

Figure 10. Evolution of the system pressures, applying *On-Off* control.

Each time the system is started, the high pressure reaches its maximum level and remains at that value for the entire *On* period. At the instant the compressor starts, an electrical current peak, of about 15.2 Ampere, is registered in the frequency converter. After a few seconds, the average value observed during the *On* period is 10.6 Ampere. An important aspect observed in the system with this controller refers to the large amount of oil that is displaced to the heat exchangers. However, when the compressor is started up in a ramp mode, with the velocity increasing slowly, this phenomenon (oil migration) is not observed. This is desired, since the compressor cannot operate without oil in the crankcase.

The adaptive fuzzy control was implemented for compressor in the refrigeration system. The system was initially started without control, operating in steady state with some imposed conditions to the experimental facility, such as the inlet water temperature in the evaporator, ($T8$), fixed in 22°C, water temperature in the evaporator exit ($T5$), of 14.6°C and the frequency of 50 Hz. At the moment the controller was operative, it was possible to verify the performance of the fuzzy control to adapt its sensibility through its scale factor in the internal adaptation mechanism. In time, with the high value of the errors of water temperature in the evaporator exit, the controller became more sensitive. As can be observed in Fig. 11, the moment that the controller, with the maximum sensibility acted in the system, increasing the compressor frequency, in other words, an immediate increment in the high pressures, where the main objective is that the exit water temperature in the evaporator ($T5$) reached the previously specified temperature (set-point) established in the controller. Under these conditions, a transient time of 25 seconds and an accommodation time of approximately 55 seconds were registered.

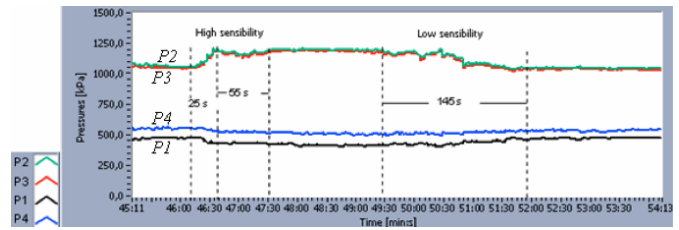

Figure 11. Evolution of the system pressures with the adaptive fuzzy controller.

Finally, Table 2 shows an interesting comparison on the basis of average power consumption to have an idea of the real benefits of using the adaptive fuzzy controller in relation to the *On-Off* control mode, working a period of 8 hours daily during 22 days. As observed, the use of an adaptive fuzzy control enables energy savings of 17.8%.

Table 2. Comparison in terms of power and energy consumption between *On-Off* and Adaptive Fuzzy control.

Control Strategy	Power Consumption	Active Energy Consumption (per year)
<i>On-Off</i>	2.92 kW	6,167.04 kWh/year
Adaptive Fuzzy	2.40 kW	5,068.80 kWh/year
Difference		-17.8%

Conclusions

The general conclusions drawn from the present investigation can be summarized as follows:

- The compressor speed was changed in a frequency range from 32 up to 70 Hz.
- Situations of insufficiency of refrigerant charge result in high discharge temperatures of the compressor and high degree of superheating. Moreover, the coefficient of performance was sensitive to the variation of the refrigerant charge in the refrigeration system.
- Changes in the compressor speed allow the system to operate according to the thermal load variation.
- As expected, the *On-Off* control does not succeed in maintaining the temperature in the set-point defined. A disadvantage of the *On-Off* control is that the average value of the controlled variable changes with the thermal load, in contrast to an adaptive fuzzy control.
- Energy savings and the improvement in the performance of the system were obtained by an adaptive fuzzy control with combination of fuzzy rules that allow treating the right way the high variation of thermal load along the day.
- Finally, the adaptive fuzzy control technique, applied to controlling the compressor speed, enabled a reduction in energy consumption of the order of 17.8%, in comparison with the *On-Off* control.

Acknowledgements

The authors gratefully acknowledge the support given to this investigation by CNPq, CAPES and FAPEMIG. The authors would like to extend their recognition to Bitzer Brazil and ACP Termotecnica for the compressor and heat exchanger.

References

Albernethy, R.B., Thompson, J.W., 1980, "Uncertainties in gas turbine measurements", ISA I-483-3.

- Aprea, C., Mastrullo, R., Renno, C., 2006, "Experimental analysis of the scroll compressor performances varying its speed". *Applied Thermal Engineering*, Vol. 26, Issue 10, pp. 983-992.
- Borja, T.J.A. 2006, "Automatization and on-line intelligent control of refrigeration systems using artificial neural networks". Doctoral Thesis – Faculty of Mechanical Engineering, Federal University of Uberlândia, MG, Brasil, 124 p. (In Portuguese)
- Carvajal, F., 2000, "Digital control of expansion valves using Fuzzy Logic", M.Sc. Thesis – Faculty of Mechanical Engineering, Federal University of Uberlândia, MG, Brasil, 74 p. (In Portuguese)
- Da Silva, F.V, Silveira Junior, V., 2001, "Fuzzy Control of the condensation temperature in a refrigeration system, Chiller". 16th Brazilian Congress of Mechanical Engineering, Belo Horizonte, MG. Proceedings of COBEM-2001 – Refrigeration, Air Conditioning, Heating and Ventilation, Vol. 5, p. 188-195. (In Portuguese)
- Da Costa, G.H., De Araujo, H.X., Mendes, N., Coelho, L., 2001, "Control of heating systems using fuzzy logic control". 16th Brazilian Congress of Mechanical Engineering, Belo Horizonte, MG. Proceedings of COBEM-2001 – Refrigeration, Air Conditioning, Heating and Ventilation, Vol. 5, pp. 62-68. (In Portuguese)
- Garcia, F.E.M., 2006, "Experimental study of an adaptive control to a refrigeration system", M.Sc. Thesis – Federal University of Uberlândia, MG, Brasil, 108 p. (In Portuguese)
- Kolokotsa, D., Tsiavos, D., Stavrakakis, G.S, Kalaitzakis, K., Antonidakis, E., "Advanced fuzzy logic controllers design and evaluation for buildings occupants thermal-visual comfort and indoor air quality satisfaction", *Energy and Buildings*, Vol. 33, No. 6, pp. 531-543, 2001.
- Koury, R.N., Machado, L.E, Ismail, K.A.R. 2001, "Numerical simulation of variable speed refrigeration", *Int. J. Refrigeration*, Vol. 24, Issue 2, pp. 192-200.
- Lida, K., Yamamoto, T., Kuroda, T., Hibi, H., 1982, "Development of energy saving oriented variable capacity system heat pump", *ASHRAE Trans*, Vol. 88, pp. 441-449.
- Nguyen, H., Goldschmidt, V., Thomas, S., Tree, D., 1982, "Trends of residential air-conditioning cyclic tests", *ASHRAE Transactions*, Vol. 88, No. 2, pp. 954-972.
- O'neal, D.L. and Katipamula, S., 1991, "Performance Degradation During ON/OFF Cycling of Single-Speed Heat Pumps Operating in the Cooling Mode: Experimental Results", *ASHRAE Transactions*, Vol. 97, No. 2, pp. 316-323.
- Shunaguan, S., 2004, "Performance representation of variable-speed compressor for inverter air conditioners based on experimental data", *Int. J. Refrigeration*, Vol. 27, Issue 8, pp. 805- 815.
- Vargas, J.V.C. and Parise, J.A.R., 1995, "Simulation in transient regime of a heat pump with closed-loop and on-off control", *Int. J. Refrigeration*, Vol. 18, No. 4, pp. 235-243.