

Hospital bed project for home care*

PROJETO DE UMA CAMA HOSPITALAR PARA INTERNAÇÃO DOMICILIAR

PROYECTO DE UNA CAMA HOSPITALARIA PARA INTERNACIÓN DOMICILIARIA

Aristides José da Silva Junior¹, Maria Belén Salazar Posso², Laurentino Corrêa de Vasconcellos Neto³

ABSTRACT

Home care within the health area has largely been improving the life quality of patients and their relatives. It has been an efficient alternative in health care as an answer to meet the needs of patients with chronic diseases, because it does not expose them to nosocomial risks, thus avoiding rehospitalizations and having to stay away from their family life, besides the evident reduction of costs. Nevertheless, it is observed there is a shortage of specific equipments that provide the necessary support in this care modality. The development of a versatile hospital bed that is easily handled is a crucial step for home care. This study addressed the development of a dismountable and lightweight hospital bed that is easy to move, transport and assemble.

KEY WORDS

Home nursing.
Beds.
Equipment.
Projects.

RESUMO

A assistência domiciliária, na área da saúde, vem contribuindo significativamente para a melhoria da qualidade de vida dos pacientes e familiares. Tem sido uma alternativa eficaz na assistência à saúde, sendo uma resposta para atender a demanda de pacientes portadores de doenças crônicas, não se expondo ao risco de infecção hospitalar, evitando as reinternações e a perda do convívio familiar, além da redução dos custos. Porém, ainda observam-se carências de equipamentos específicos para dar suporte a esta modalidade de assistência. A construção de uma cama hospitalar versátil, permitindo facilidade na manipulação, configura-se em um dos pontos cruciais na assistência domiciliar. Este trabalho trata do desenvolvimento de uma cama hospitalar desmontável e leve, que facilita sua mobilidade, transporte e montagem.

DESCRIPTORIOS

Assistência domiciliar.
Leitos.
Equipamento.
Projetos.

RESUMEN

La asistencia domiciliar en el área de la salud ha estado contribuyendo significativamente en la mejora de la calidad de vida de los pacientes y familiares. Se ha convertido así en una alternativa eficaz en la asistencia a la salud, convirtiéndose en una respuesta para atender las demandas de los pacientes portadores de enfermedades crónicas, los cuales no se ven expuestos a los riesgos de las infecciones hospitalarias, evitan las reinternaciones y la pérdida de la convivencia familiar, sin mencionar la reducción de sus costos. Sin embargo se observa aún la carencia de equipamiento específico para dar el soporte necesario para ésta modalidad de asistencia. La construcción de una cama hospitalaria versátil que permita una fácil manipulación se constituye en uno de los puntos cruciales en la asistencia domiciliar. Este trabajo trata acerca del desarrollo de una cama hospitalaria desmontable y liviana, de fácil movilidad, transporte y montaje.

DESCRIPTORIOS

Atención domiciliar de salud.
Lechos.
Equipo.
Proyectos.

* Part of the thesis "Cama Hospitalar: desenvolvimento de uma alternativa para a internação domiciliar", PostGraduate BioEngineering Program of the Instituto de Pesquisa e Desenvolvimento of the Universidade do Vale do Paraíba, 2003. ¹Nurse. Assistant Professor for the Nursing Course of the Instituto de Ciências Exatas e Naturais, Universidade Federal de Mato Grosso. Mato Grosso, MT, Brazil. aristides@ufmt.br ²Nurse. PhD in Nursing. PostGraduate Program of the Escola de Enfermagem da Universidade de São Paulo. Professor of the Nursing Course for the Faculdade de Ciências da Saúde and the Instituto de Pesquisa e Desenvolvimento of the Universidade do Vale do Paraíba. São José dos Campos, SP, Brazil. Chairman of the Centro de Estudos de Enfermagem of Santo André, SP, Brazil. mbelen@terra.com.br ³Engineer. PhD in Engineer. Universidade de São Paulo. Professor of the Instituto de Pesquisa e Desenvolvimento of the Universidade do Vale do Paraíba. Researcher for the Centro Técnico Aeroespacial. São José dos Campos, SP, Brazil. vasko@ieav.cta.br

INTRODUCTION

Brazil's demographic profile has changed. A decrease in mortality rates and in lifespan will increase the number of old people to 32 millions⁽¹⁾ in 2025. Significant changes in the population pyramid and their impacts on social, cultural and epidemiological areas have triggered a number of modifications in the care provided to individuals subject to restrictions in their daily life activities.

In this sense, at the end of this study the author⁽²⁾ makes some considerations on the importance of re-dimensioning spaces where nurses work in the programs of assistance to the elderly allowing sensitive care, consistent with the clientele and their family by meeting their needs according to their perceptions targeting on more adhesion to said programs. Additionally, an essential nurse-patient interpersonal relationship is established favoring the acceptance of the disease⁽²⁾. Performing in the assistance as a whole consists of using healthcare technologies to provide healthcare aiming at promoting and increasing wellbeing in the interrelations with the others.

The need of re-dimensioning the spaces to meet patients and their family's needs in a complex way in addition to promoting the continuity of the treatment and recovery generate alternatives and strategies of de-hospitalization and humane care provided at home (locus of the care), i.e., rendering hospital care within the home focused on promoting, preventing and rehabilitating individuals articulated with third parties' assistance, if required, thus reversing high social costs⁽³⁾.

Providing homecare involves mobilizing professionals and caretakers, many of them, and patients' relatives. The homecare strategy is located in the evolution of the hospital-centered assistance – technicians outside the context of users' life history providing full healthcare – an alternative healthcare modality provided by means of humane practices that respect users' rights, preserve their family relations and socio-cultural values⁽⁴⁾.

Healthcare based on a set of activities rendered to clinically stable patients demanding intense care outside the ambulatory ward by a multi-professional homecare team by using healthcare technologies is legally disposed in RDC no. 11 of 2006⁽⁵⁻⁷⁾. The RDC no. 11 of 2006 defines homecare as

a set of activities rendered at home characterized by full-time care provided to a patient suffering from a more complex clinical condition and in need of specialized technology.

The proposal of the Pact for Health⁽⁵⁾ instituted by Administrative Rule GM 399/2006, composed of the following pacts: Pact for Life, Pact for the Defense of the Unique

Healthcare Service (SUS) and Pact of SUS Management involves the promotion of improvements to the quality and quantity of healthcare services offered to the population and guaranty of access to all those services; changes in the managers' paradigm so that autonomy is achieved regulated by the state or municipal healthcare services with rules focused on the population's healthcare needs, the responsibilities being defined at the three governmental levels. The health of the elderly is one of the priorities of the Pact for Life and its main focus is to reach local-regional goals.

Historically, the first homecare unit was set in the USA in 1947 to relieve the hospital system in order to offer patients and relatives a more favorable therapeutic environment⁽⁴⁾. The data presented by the American Homecare Association report that in the last 05 years approximately eight million Americans have required this type of service, mobilizing about 19 thousand homecare providers, and that these figures tend to triple in the years to come^(4,8).

In Brazil it is believed that the first homecare services took pace when the Medical and Emergency Homecare Service (SAMDU) was created in 1949, maintained by the pension agencies that exist until today^(4,8).

Once homecare is acknowledged as an effective healthcare modality with positive results, a significant decrease in final costs has been obtained in the treatment of patients and more quality care.

Homecare grows exponentially as a result of the increase in lifespan. To help homecare providers the Ministry of the Health⁽⁹⁾ has published the Practical Guide of the Homecare Provider, with a simple language, to render guidance on self-care, on the care provided to others, on health promotion to ensure and maintain the life of bedridden people or those whose daily-life activities are limited, targeting on a better quality of life for both sides.

Once homecare is acknowledged as an effective healthcare modality with positive results, a significant decrease in final costs has been obtained in the treatment of patients and more quality care. Healthcare focused on observing health and providing humane care has been the proposal of the homecare rendered since the end of the XVIII century in Europe. It is an area of application and rationalization of the use of hospital beds⁽¹⁰⁾, mainly considering that the risks involved in the hospitalization of patients with acute and chronic conditions increase when they get old, which is evidenced by the multi-pathologies hospitalization involves. Maintaining the health of the elderly is one of the main concerns and challenges for the elderly, their family and healthcare providers⁽¹¹⁾.

In spite of the excellent results obtained in homecare related to quality labor and the family and patients' wellbeing, there are still obstacles and unfavorable deficiencies in this healthcare modality related to equipment and instruments available in the market, which are usually designed for hospital care, where the architectural dimensions of hospitals are taken into account. They meet spe-

cific technical construction rules, different from those for home architecture. Homecare services should provide equipment, medicine and materials as defined in the Homecare Plan⁽⁵⁾.

To meet the regulations in force, and talking specifically about hospital beds able to accommodate the average human height, the dimensions are as follows: 1.90m long and 0.90m wide; the bed frame is made of one single piece with small variations according to manufacturers. Therefore, technological alternatives should be designed allowing simplifying pieces of equipment, making them portable and user-friendly, increasing the possibility of homecare and making it easier⁽¹²⁻¹³⁾.

The current technological development still fails to meet the needs of the area, so much so that a hospital bed is among the pieces of equipment that are difficult to handle and adapt to the home because of its size, weight and the need of moving it periodically. Generally speaking, the hospital beds available to be used at the home environment weigh from 90 to 200 Kg.

Additionally, the home environment may impose architectural and ergonomic barriers arising from small elevators or stairs and narrow corridors as the only way to enter the home. In this environment, due to the design and height of hospital beds, with their compact bed frame, they are difficult to move and accommodate in the home⁽¹⁴⁾ and, at the same time, as already said, these heavy beds have to be carried manually, and sometimes in buildings without elevators, for many stories up the stairs, which are often narrow and circular.

The increments proposed for a home hospital bed are limited to the topics criticized in the existing hospital bed models in the market, which are: the material used to build the bed related to the product's weight; size when disassembled for transportation; and the assembling process, although they also refer to characteristics such as durability and resistance.

The research and development involved in building a prototype were based on the structure of a simple hospital bed usually used in homecare and/or hospitals. The difficult access of these beds to different architectural environments was the most significant motivation for this study.

Thus, the objective of this paper is to propose the development of a prototype of a user-friendly, flexible, portable home hospital bed, with low price and accessible cost targeting on easing transportation and allowing faster assistance to clients/patients in need of homecare.

METHOD

This is an applied research and, as such, defined as a research focused on finding a solution for an immediate problem and whose final goal is scientifically planning a change in a problematic situation⁽¹⁵⁾.

Applied researches are those that work with immediate objectives once researchers are in a hurry to get the return on the resources used⁽¹⁶⁾.

Therefore, we present here a proposal for a prototype of an articulated home hospital bed with reduced size and width when the headboard, footboard and side bars are disassembled. The innovations involve an articulation of the bed frame in the middle and foldable side bars towards the middle of the bed, thus easing transportation and finding a place in the home.

As to the material to be used in the prototype, a washable rust-resistant material has been chosen and, if possible, a recyclable, low price material, with a good resistance/weight relation. Aluminum was chosen once it meets these requirements. The decrease in weight of aluminum laminated plates related to steel is about 40% to 50%⁽¹⁷⁾ and aluminum has a combination of features that makes it much more useful in engineering, with low density (2.70g/cm³) and good resistance to corrosion in most of the natural environments once its specific mass and rusting potential are lower than those of the steel⁽¹⁸⁾.

Additionally, although pure aluminum has low mechanical resistance, aluminum alloys are resistant and can be molded, welded, are hard, can receive quality finishing and are recyclable, approved by the air force and train industries, and they can take an adequate appearance in civil construction applications, such as, for instance, with a coating able to strengthen even more the material's natural resistance to corrosion and, so, it is able to meet the objective of this proposal perfectly⁽¹⁷⁻¹⁹⁾.

So, based on these characteristics, the home hospital bed is basically composed of two aluminum structures, U-shaped headboard and footboard that fit into each other and in those structures, and they also have threaded swiveled wheels at the end of each one of its four legs, allowing the bed to go up and down in an approximate course of 160 mm.

The two side bars are articulated, removable and built with aluminum. The articulation systems are made with steel, one at each extremity of the bed, allowing the Fowler and Trendelenburg positions by manipulating the levers, which are common in hospital beds. Figures 1, 2 and 3 illustrate the structure and assemblage of the prototype proposed, evidencing the points that can be folded and adjusted.

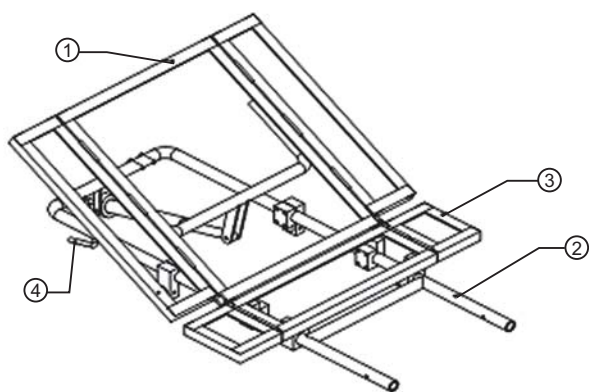

1. Part of the headboard in the Fowler position;
2. Preparation to fit in the second part of the home hospital bed;
3. Foldable side bars towards the middle, which decreases the bed's size;
4. Main U-shaped structure of the home hospital bed.

Figure 1

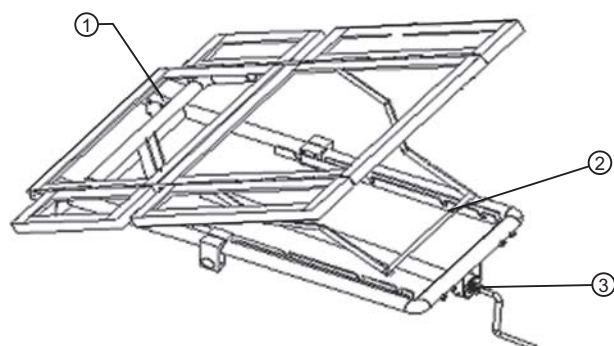

1. Preparation to fit in the first part;
2. Part of the footboard in the Trendelenburg position;
3. Lever to position the headboard.

Figure 2

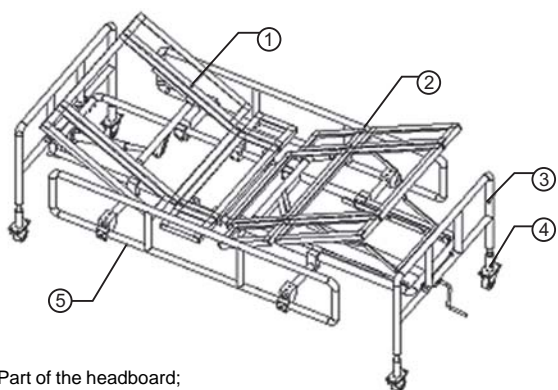

1. Part of the headboard;
2. Part of the footboard;
3. Footboard assembled;
4. The threaded feet allow controlling the height of the bed;
5. Side protection bar.

Figure 3

Figure 3 shows the structure and assembling scheme of the home hospital bed as a whole, which will still receive an aluminum plate.

The increments proposed for a home hospital bed are limited to the topics criticized in the exiting hospital bed

models in the market, which are: the material used to build them related to the product's weight, size when disassembled for transportation and assemblage, although they also refer to characteristics such as durability and resistance.

The interaction among several areas of knowledge allows an exchange among different professions, opening up the imagination and setting a creative stance in the most different professional areas. Therefore, based on this idea, the conception of the prototype for a home hospital bed was founded on principles of Nursing and Biomedical Engineering to favor and deliver more benefits to the community.

The innovative proposal for this home hospital bed is based on the high levels of co-morbidities found in the world population, which leads to several developments, such as an increase in the periods patients have to stay in hospital and readmissions resulting from lack of preparation to host these individuals in their own home.

Thus, the home hospital bed will weigh approximately 50 Kg, differently from conventional hospital beds whose weight usually varies from 90 to 200 Kg. The 50 Kg of the home hospital bed will be divided into 10 Kg for headboard and footboard, the side bars will weigh 5 Kg and 17.5 Kg each part of the bed frame, totaling 35 Kg once, as it has already been mentioned, it is foldable.

The heaviest part of the home hospital bed (bed frame) is 54.7% lighter, i.e., 35.2 Kg compared to the bed exiting in the market, which weighs 64 Kg. Also with the reduction in the bed frame and foldable side bars, the length and width would decrease from 1.90m to 0.95m and from 0.90m to 0.45m, respectively, enabling to carry the bed in small and middle-sized vehicles and easing the movements in corridors and elevators, solving the difficulties faced when the current models are used⁽²⁰⁾.

This solution also contemplates, despite indirectly, the items listed in the Brazilian Policy for the Elderly, which ensures the elderly humane and integrating assistance^(21,22) by softening the difficulties related to home architectural barriers, the object of constant complaints made by healthcare providers who work at patients' home and have to improve, not always in a way adequate to patients' safety.

Within the ambit of the SUS, the homecare option may perform as a *seam* between hospital and primary healthcare, strengthening the system and particularly the Family Health Program whenever possible. To be successful in homecare one has to acknowledge the limitations of competences and feasible solutions found in primary healthcare, homecare and hospital assistance. Those limitations are set by the complexity of the cases, qualification of healthcare providers, multi-professional action capacity, mastering of technologies and characteristics of the managerial processes of the care⁽²¹⁾.

In this sense, in this proposal the potential of mechanical and ergonomic risks was a concern⁽²²⁾ once they can

reach healthcare providers and homecare providers, confirming the importance of executing this project.

CONCLUSION

The home hospital bed proposed here enables simplifying and assembling the equipment, eases the transportation process due to its reduced size and weight and also due to its variable height. In addition to being portable and easy to handle to solve the problems faced when using the current models, it also benefits the care to be provided.

On the other hand, it also approaches the need of the Brazilian hospital industry of adapting equipment. The home hospital bed, due to its reduced size and weight, is easy to transport and assemble at home, avoiding excessive and unnecessary efforts by healthcare providers in the whole process, in addition to easing providing nursing care to patients/clients.

The bed frame is also smaller and, consequently, it is shorter and narrower when disassembled. In the alterations proposed the bed will have an estimated weight of 50 Kg, and the total weight of the bed will be about 45% to 75% lower than a regular hospital bed.

We believe that this proposal will help minimizing the problems arising from home architecture and healthcare providers' physical efforts, thus meeting the needs of a clientele that increases more and more as a result of de-hospitalization. In this sense, the proposal stands for an important contribution to homecare providers, improving patients' quality of life, minimizing expenses with hospital admissions and also contributing to the hospital industry as to the interaction of the areas of knowledge in healthcare and bio-engineering, incrementing the creation of alternatives oriented towards actual needs of users and clients.

REFERENCES

1. Brasil. Ministério da Saúde. Estatuto do Idoso. Brasília; 2003.
2. Muñoz LA, Price Y, Gambini L, Stafanelli MC. Significados simbólicos de los pacientes com enfermedades crônicas. Rev Esc Enferm USP. 2003;37(4):77-84.
3. Silva KL, Sena R. Integralidade do cuidado na saúde: indicações a partir da formação do enfermeiro. Rev Esc Enferm USP. 2008;42(1):48-56.
4. Rehem TCMSB, Trad LAB. Assistência domiciliar em saúde: subsídios para um projeto de atenção básica brasileira. Ciênc Saúde Coletiva. 2005;10 Supl:231-42.
5. Brasil. Ministério da Saúde. Agência Nacional de Vigilância Sanitária (ANVISA). Resolução Diretoria Colegiada RDC 11, de 26 de janeiro de 2006. Dispõe sobre o Regulamento Técnico de Funcionamento de Serviços que prestam Assistência Domiciliar [legislação na Internet]. Brasília; 2006. [citado 2008 mar. 15]. Disponível em: http://www.saude.sp.gov.br/resources/profissional/acesso_rapido/gtae/saude_pessoa_idosa/rdc_anvisa.pdf
6. Merhy EE. Agir em saúde: um desafio para o público. São Paulo: Hucitec; 1997.
7. Silva KL, Sena R, Leite JCL, Seixas CT, Gonçalves AM. Internação domiciliar no Sistema Único de Saúde. Rev Saúde Publica. 2005;39(3):391-7.
8. Bertolli Filho C. História da saúde pública no Brasil. São Paulo: Ática; 1996.
9. Brasil. Ministério da Saúde. Secretaria de Atenção à Saúde. Secretaria de Gestão do Trabalho e da Educação na Saúde. Guia prático do cuidador. Brasília; 2008.
10. Silva KL, Sena R, Leite JCL, Seixas CT, Gonçalves AM. Internação domiciliar no Sistema Único de Saúde. Rev Saúde Publica. 2005;39(3):391-7.
11. Carvalhais M, Sousa L. Comportamentos dos enfermeiros e impacto em idosos em situação de internamento hospitalar. Rev Eletrônica Enferm [periódico na Internet]. 2007. [citado 2008 abr. 17];9(3):[cerca de 21 p.]. Disponível em: <http://www.fen.ufg.br/revista/v9/n3/v9n3a04.htm>
12. Duarte YAO, Diogo MJD. Atendimento domiciliar: um enfoque gerontológico. São Paulo: Atheneu; 2000.
13. Monteiro Filho AJ. Estudo do aspecto físico da Unidade de Internação em Hospital Geral [tese]. São Paulo: Faculdade de Saúde Pública, Universidade de São Paulo; 1972.
14. Pavarini SCI, Neri AL. "Compreendendo dependência, independência e autonomia no contexto domiciliar". In: Duarte YAO, Diogo MJD. Atendimento domiciliar: um enfoque gerontológico. São Paulo: Atheneu; 2000. p. 49-70.
15. Polit DF, Hungler BP. Fundamentos de pesquisa em enfermagem. Porto Alegre: Artes Médicas; 1995.
16. Parra Filho D. Metodologia científica. São Paulo: Futura; 1998.
17. Póvoa AA. Aplicação de chapas de alumínio laminadas na fabricação de rodas para a indústria automobilística. In: Anais do 6º Seminário de Tecnologia da Indústria do Alumínio; 1995; São Paulo, BR. São Paulo: Associação Brasileira do Alumínio; 1995. p. 519-32.
18. Smith WF. Princípios da ciência e engenharia de materiais. 3ª ed. Rio de Janeiro: MacGrawHill; 1998.

19. Associação Brasileira de Alumínio (ABAL). As aplicações do alumínio [texto na Internet]. São Paulo; 2008. [citado 2008 mar. 19]. Disponível em: www.abal.org.br
20. Silva Junior AJ. Cama hospitalar: desenvolvimento de uma alternativa para a internação domiciliar [dissertação]. São José dos Campos: Instituto de Pesquisa e Desenvolvimento, Universidade do Vale do Paraíba; 2003.
21. Brasil. Lei n. 8.842, de 4 de janeiro de 1994. Dispõe sobre a Política Nacional do Idoso, Cria o Conselho Nacional do Idoso e dá outras providências [legislação na Internet]. Brasília; 1994. [citado 2008 mar. 15]. Disponível em: <http://www.planalto.gov.br/ccivil/leis/L8842.htm>
22. Brasil. Ministério do Trabalho e Emprego. Programa de Prevenção de Riscos Ambientais. NR 9-109.000-3, de 22 de dezembro de 1977 [legislação na Internet]. Brasília; 1977. [citado 2008 jan. 20]. <http://www.mte.gov.br/Empregador/segsau/Legislação/Normas>