

## The NoBLOCK Technology A Major Breakthrough in Wet High Intensity Magnetic Separation (WHIMS)

<http://dx.doi.org/10.1590/0370-44672015680116>

### José Pancrácio Ribeiro

Electrical engineer

Nova Lima – Minas Gerais -Brazil

[pancracio@gaustec.com.br](mailto:pancracio@gaustec.com.br)

### Cláudio Henrique Teixeira Ribeiro

Electronics engineer

Nova Lima – Minas Gerais -Brazil

[claudio@gaustec.com.br](mailto:claudio@gaustec.com.br)

### Abstract

Since its introduction in 1963 by G.H. “Jones”, WHIMS MS has proven to be, worldwide, a major technology for separating several types of ore fines from their contaminants. Unfortunately, despite its superb characteristics, even if the best operational procedures are followed, one main issue lasts. It is the blocking of the matrix gaps by oversized particles. Protection screens have been employed to wipe out this blockage, though only partially effective. Creative methods and tools have been developed to facilitate and speed up the cleaning process. But, in fact, along 50 years, the matrix blockage nightmare lingered defying the minds involved with Whims operation. The recent environment demands and the need to reduce costs by recovering ore ultra-fines currently being disposed in tailing ponds, further posed a new challenge. Reportedly these ore ultra-fines, typically below 75 microns, demand smaller gaps for its recovery than today’s bottom limit 1.5 mm. The blockage issue worsens even more and to solve it, Gaustec Magnetism, after two years of research and test work, finally succeeded in developing The Brand New NoBLOCK® Technology presented here.

**keywords:** magnetic Separation, whims, tailing ponds, iron ore fines, environment protection, matrix, matrix blockage, protection screens.

### 1. Introduction

Among the most common Magnetic Separators of its class, the Jones Type, patented in 1963 by the Englander G. H. “Jones”, Figure (1), and further improved in 1972 by the Canadian W. J. Stone, Figure (2), is the most used MS for dressing ore fines.

Jones for sure was the brilliant mind behind the first sound Whims concepts including the Matrix Box with the grooved plates as we know today. That is why this machine is well known everywhere as the “Jones”.

W. J. Stone on the other hand widely improved the “Jones” concept with such an overall sound design (mechanical, electrical and magnetic design features) that turned its manufacture and application widely spread in the mining industry. The practical approach and industrial vision from W. J. Stone were so efficient that they

made it possible to establish a standard that turned it into a well-known bestseller.

These machines are provided with electromagnetic coils and iron poles to generate a background magnetic field. In order to achieve a high intensity and high gradient, the background magnetic field is further amplified by means of grooved magnetic stainless steel plates. These plates mounted side by side in several layers form the matrixes boxes. These matrix boxes are typically mounted surrounding a low carbon steel rotor, which also provides a high permeability closed path to concentrate the field lines. The function of the rotor is also, by rotation, to transport the matrixes boxes in front of the magnetic poles where they are magnetized and as such catch, between the grooves, the

magnetic particles contained in the slurry flow passing through it. After the matrix boxes have caught the magnetic particles, and discarded the non-magnetic ones, the rotor transports them away from the magnetic pole. Halfway from the next pole, where the vertical component of the magnetic field is zeroed, the magnetic particles are scoured out as product. In fact, the separation process is that simple and further details can be observed in movies at Gaustec website.

Just to display the Whims structure and components, and at the same time compare the early design of Mr. Jones and the huge technical improvement made by Mr. Stone, both concepts are now displayed in old-fashioned drawings.

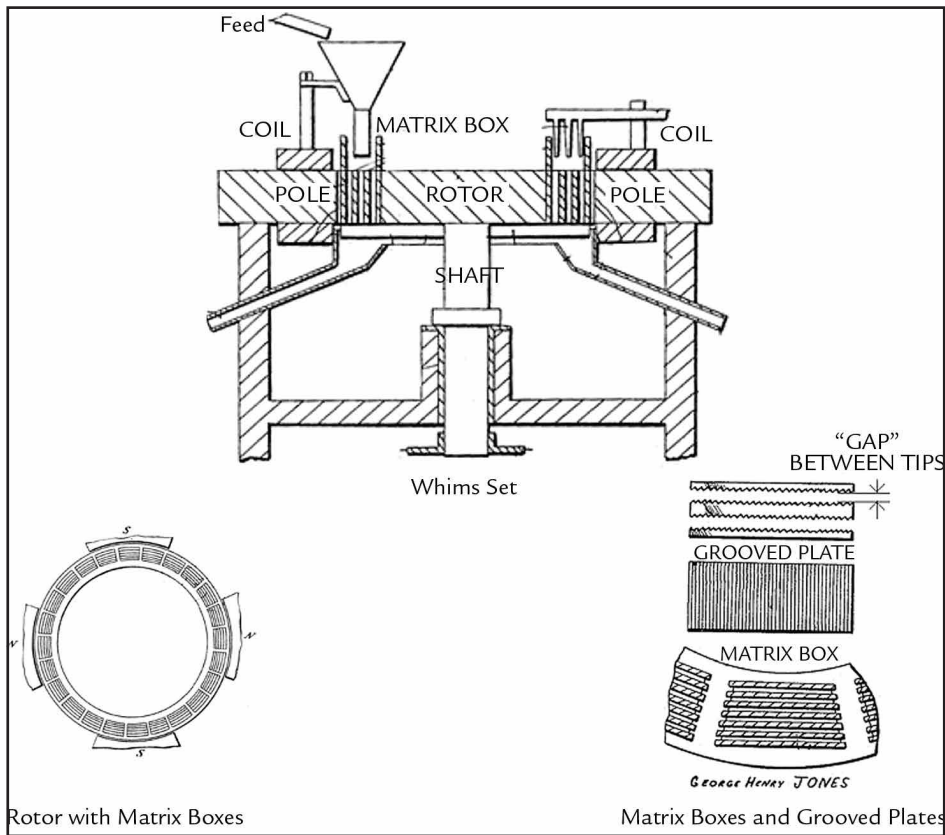

Figure 1  
The G.H. “Jones” whims, year 1963

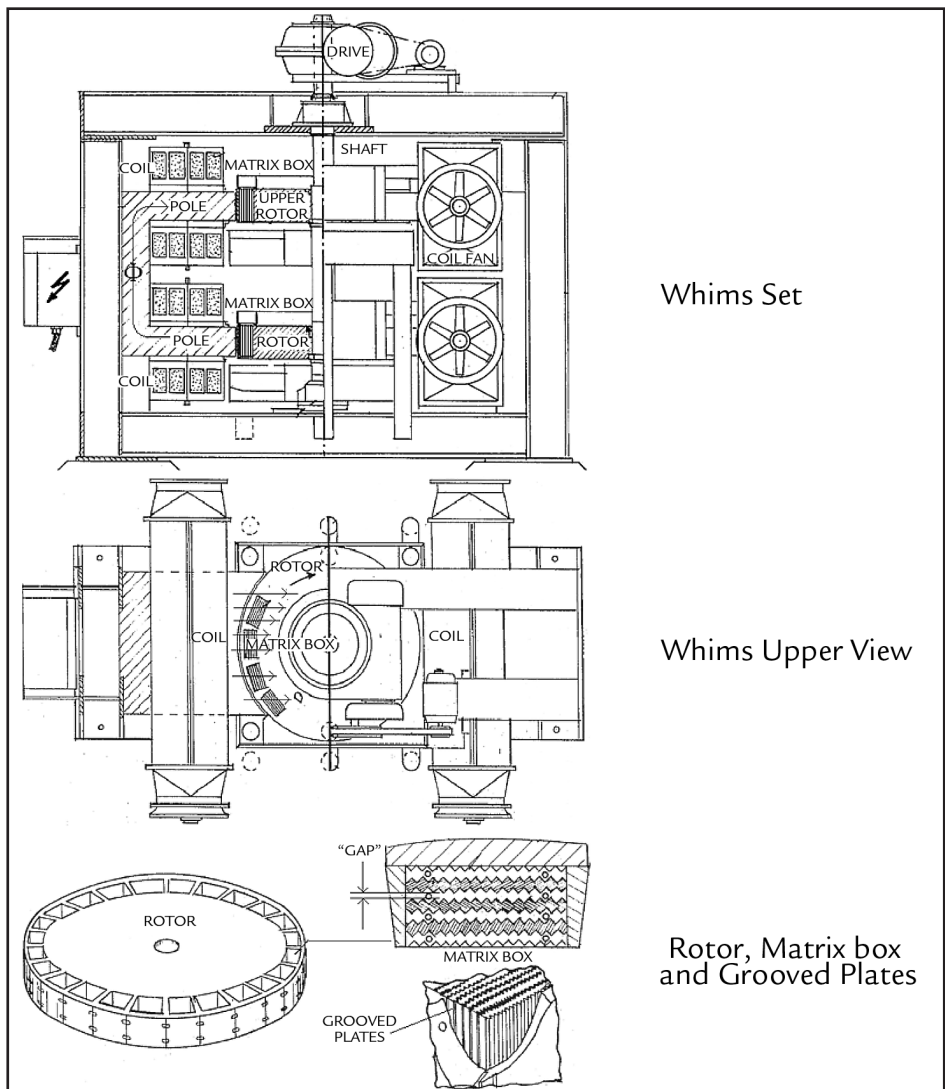

Figure 2  
The W.J. “Stone”whims, year 1972

## A 50-Year Old Problem: The Whims Matrix Blockage

One can easily depict, from the explanations and also from these old fashioned drawings displayed, the main components of the Whims MS. The described principle of operation is, for sure, also well understood.

The flexibility to adapt the Whims performance to several ore types, once provided with the correct grain size liberation, is a key factor.

In fact, flexibility derives from several process variables that can be easily adjusted by the expert, mainly:

Feed Rate; Feed % Solids, Gap distance between grooved plate tips,

Magnetic Field intensity, Rotor Speed, Middling's and Magnetic Concentrate washing spray pressures. Some plant design variables like Height of the Slurry Feed Distributors (which defines the speed flow of the slurry passing through the matrix gaps) and, as well as, some standard and sound practices in the Process Flow Sheet design, also play an important role for performance success.

As long as the Gap space between grooved plates is clean enough, allowing the unhindered slurry flow through the matrix, and proper process settings are achieved, everything works fine accord-

ing to schedule. In fact, the vital room between the grooved plates, whose Gap distance between the tips is the mandatory GAP Factor, is the vital space where the magnetic separation process takes place.

On the other hand, the blocking of the Matrix Gaps by oversized particles renders the Whims useless. This is the Matrix Blockage problem nightmare, that along 50 years, lingered defying the minds involved in the Whims operation. Below Figure (3) displays some examples of Blocked and Clean Matrixes.

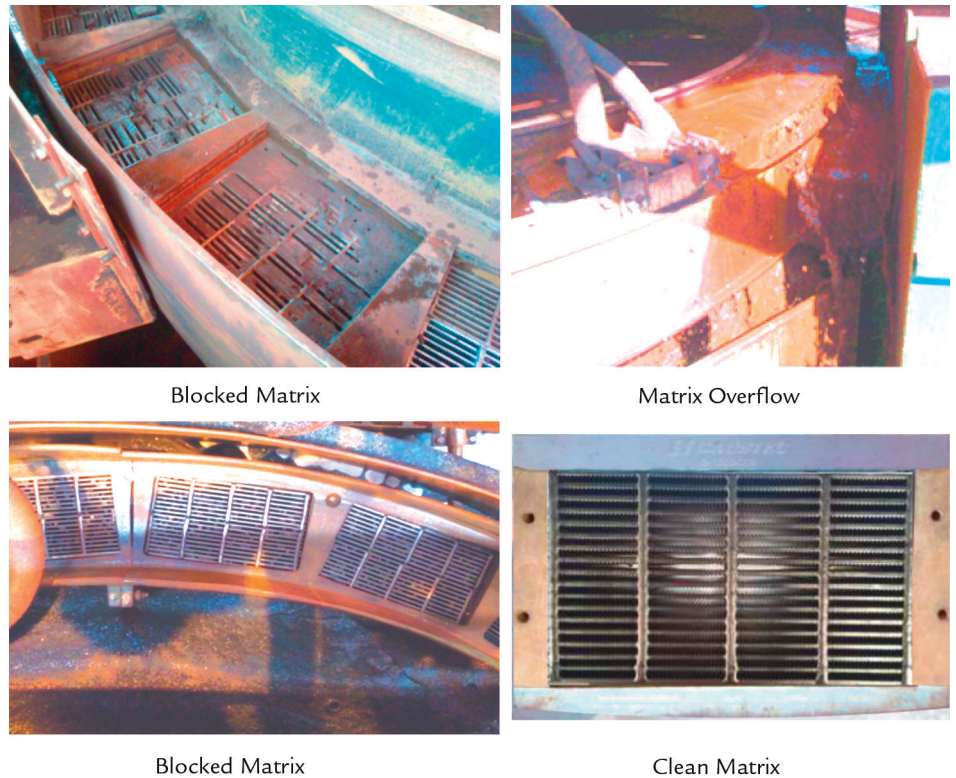

Figure 3  
Some examples of  
Blocked and Clean Matrixes

The total or partial blockage of the slurry flow stops the magnetic separation process in the same manner the blockage of the holes of a screen panel stops the screening process.

A point to remark is that while the blockage of a screen is promptly eliminated by the operation of personnel because it is aimless to go on producing out of specs products, usually the same decision of stopping does not take place immediately in the case where the Matrix Boxes of a Whims Magnetic Separator are blocked.

There are several reasons for this and the first one, we suppose, is typically behavioral.

The cleaning process of the matrixes

is so exhausting and time consuming that people refuse to believe their eyes when the Matrix Boxes start blocking, preferring to deny what is going on. In a typical Whims type, there are around 5000 slots in the Matrix Boxes to be cleaned up with hammer and steel blades. It means a long day of extenuating tough work.

The second reason is that, since the blockage increases gradually, people try to go on checking the quality and yield of the product, as long as they can, sometimes resulting in production chaos. Despite this shortcoming, the Whims technology stayed alive for so long because of its unrivaled results when using this type of magnetic Separator, and everyone involved with its shortcomings has looked

forward to ways to relieve its effects and improve chances of survival.

Along the years, protection screens before the Whims feed have been the standard choice to avoid this blockage, though this proved to be only partially effective. Several reasons can be related to its malfunction. One is that standard screens available in the market are intended for commercial production and even if, some oversized particles go into the undersize, the yield is accepted, provided the oversize amount falls into contract tolerances. For Matrix Box protection, there is no room for oversized particles in the undersize, since protection must be 100 % safe. Even if a tiny amount of oversized particles

flow into the Whims, it is just a matter of how long it will take to completely block the Matrix Boxes. Another point is related with the screen panel's material and dimensions. Typically, screen panels are made out of polyurethane and due to its plastic characteristics and small

dimensions they can easily enlarge its openings by the vibrational forces of the screen forcing the oversized particles to pass through. Wear is also an issue that, after some time, enlarges the openings. Even though a standard screen somehow provides some protection, its use has not

proven to be a 100 % safe solution.

Along the years, creative methods and tools have been developed to facilitate and speed up the cleaning process of the blocked Matrixes with success in some extent, facing the effects rather than properly addressing the causes.

## The NoBLOCK Technology

Recently, demanding environment rules, and sinking iron ore prices have forced production cost reduction, posing a new challenge: the recovery of ore ultra-fines currently being disposed of in tailing ponds. Reportedly these ore ultra-fines, typically below 75 microns, demand smaller gaps for its recovery than today's bottom limit 1.5 mm and

even higher magnetic field intensities. The blockage issue has worsened even more and to solve it, Gaustec Magnetism, after two years of research and test work, finally succeeded in the development of The Brand New NoBLOCK® Technology presented here.

The core of this technology bloomed from the main weakness of the standard

screen available in the market: the screen panel. To achieve the best protection, a brand new screen had to be found. This screen should have openings that could stand unchanged and should be wear resistant. This screen element should also guarantee that once a particle has passed through it, it should also pass through the matrix openings.

### 1. Matrix Box Slice

To match these features, the answer was that the screen panel should be made out of the same steel Matrix Box, as shown in Figure (4), it was intended to protect against oversized particles. The manufacture was achieved by just cutting

slices of proper thickness from the Matrix Box. The thickness of the slices, after some screening tests, was found to be from 10 to 20 mm, quite different from the steel wire meshes that are also used in the screening market, whose small dimensions also lead

to a reduced life spam. The thickness of these tabs, which were generated by the cutting process, display dimensions as cited above, and have a very long life spam. This characteristic ensures the great reliability of the protection screen.

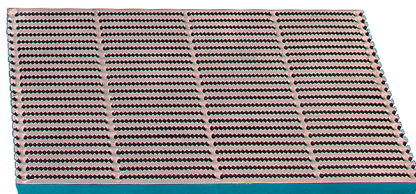
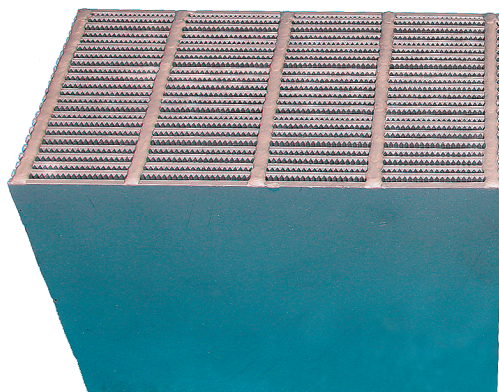

Figure 4  
Matrix Box and Slice

### 2. Curved Matrix Boxes Screen Panels

Considering that the screen panel slice manufactured displayed a flat surface, and considering that its thickness creates a long path to be crossed

by the particles passing through, these screen panels were curved, according to figure 5, to such an extent that they provide a path whose opening begins

at the standard Gap and opens gradually towards the output. This geometry provides a loose path for the outgoing undersized particles.

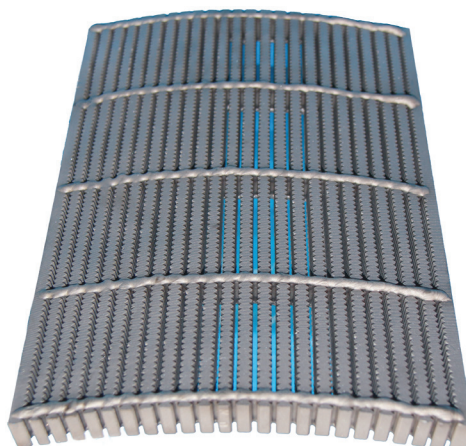

Figure 5  
Curved Matrix Boxes Screen Panels

### 3. Rotor Matrix Assembly

The ruggedness of the Matrix Screen Panel had also to be extended to sound mechanical concepts to achieve the needed 100 % protection (NoBLOCK) of Whims against oversized particles. The first choice has been to use the rotating screen drive concept instead of the standard vibration principle which is frequently applied for screen-

ing machines. The absence of vibration increases the reliability of the frame structure by eliminating the mechanical stresses on the welds and connecting rods. This type of drive provides the smooth operation of the NoBLOCK Rotor Screen and no special basement is necessary for its installation. Above all, the rotating operation reduces the drive

power compared to vibrating screens of the same feed capacity by at least five times. The matrix rotor is constructed as can be seen in Figure (6) joining several rings. These rings are manufactured by welding several Matrixes Screen Panels together and this rugged construction also plays an important role to yield a solid and fail proof mechanical structure.

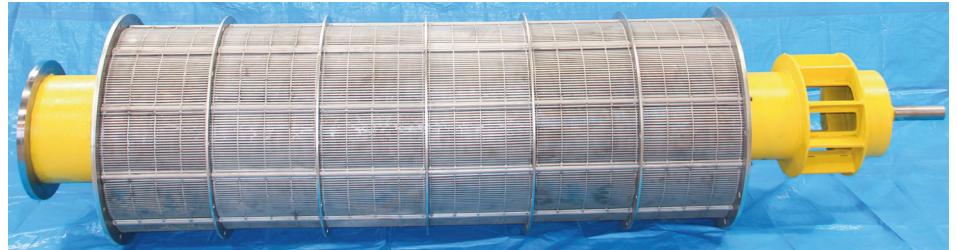

Figure 6  
Rotor Matrix Assembly

### 4. The NoBLOCK Rotor Screen Principles of Operation

The Rotor constructed as described above, is mechanically supported and driven at the same time by a motor gearbox, as displayed in Figure (7). The Rotor speed is set by a frequency converter to achieve the best screening efficiency. The Slurry Feed flows inside the Rotor and is screened by the Matrix Screen Panels. The oversized particles travel inside the rotor at a speed proportional to the Rotor

revolutions per minute (RPM) and helped by its 10-degree slope downwards. At the end of the Rotor, the oversized particles get out flowing through the Oversize Output. The particles with the right size to be fed into the Whims pass through the Screen Gaps and flow away through the undersize output. To increase the protection grade, the Gap openings of the Screen Panels are chosen smaller than the

Gaps of the Matrix Boxes installed in the Whims MS. Water sprays mounted above the Rotor remove the particles that pegged into the Gaps throwing them back to the Rotor's interior. These water sprays keep the rotor cleaned to correctly perform its screen function. An Emergency Overflow output under the NoBLOCK Screen provides the path when slurry in excess of the rated capacity flows into the input.

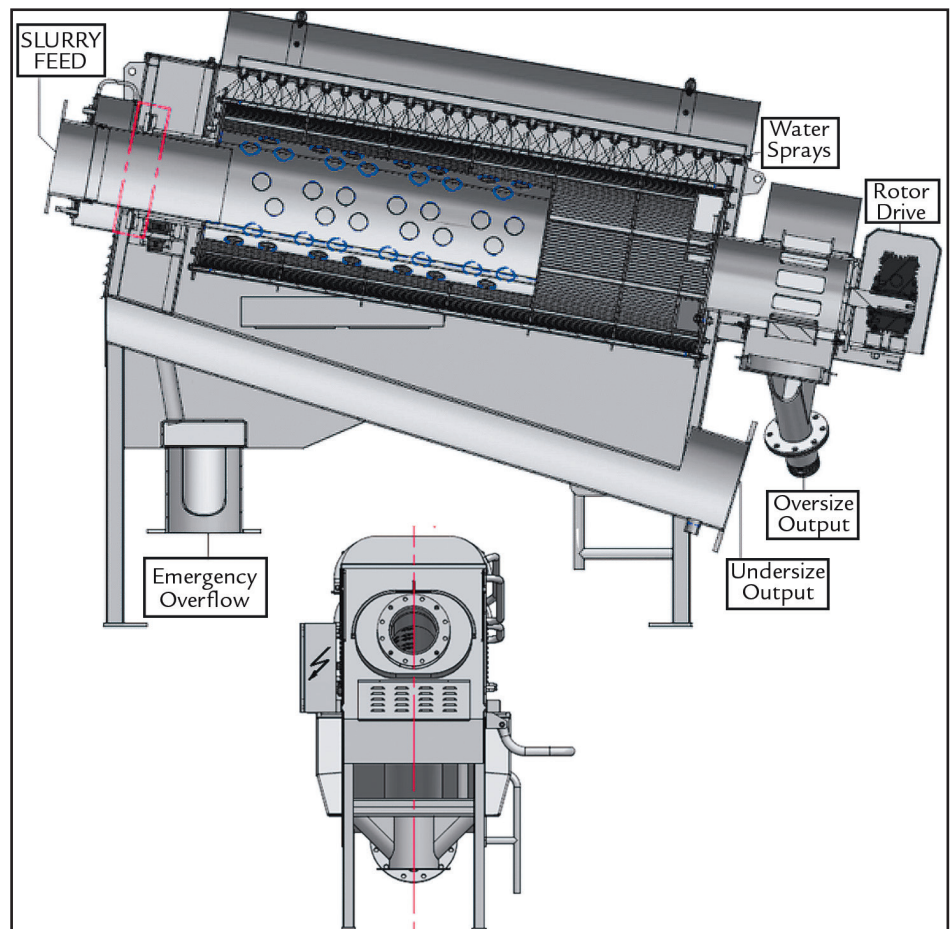

Figure 7  
The NoBLOCK Rotor Screen

## 5. Conclusion

Several NoBLOCK Rotor Screens have been operating for almost a year now, providing 100 % efficient protection of WHIMS Magnetic Separators at some

Mining Sites. The concepts presented here are the results of constant improvements along the above time frame. The oversize blocking has been reportedly eliminated.

Further running time of the equipment is needed to get acquainted with the lifetime of the main components and to confirm the protection efficiency in the long run.

## 6. References

- LUZ, A.B., SAMPAIO, J.A., FRANÇA, S.C.A., *Tratamento de minérios*, (5th ed.) Rio de Janeiro: CETEM/MCT, 2010.
- CHAVES, A.P. *Teoria e prática do tratamento de minérios*. (2nd ed.) São Paulo: Signus Editora, 2002.v.1.
- JONES, G.H. Patent us 3.326.374 - Magnetic Separator With Washing an Scouring Means, 1963.
- STONE, W.J., Patent us 3.830.367 - Wet High Intensity Magnetic Separator, 1972.

---

Received: 20 July 2015 - Accepted: 12 August 2015.