

Analysis of strengthening procedures of reinforced concrete highway bridges: a brazilian case study

Análise de procedimentos de reforço de pontes rodoviárias: um estudo de caso brasileiro

D. M. CARVALHO ^a

davidsonmatosdnt@gmail.com
<https://orcid.org/0000-0003-3412-6552>

J. M. F. CALIXTO ^a

calixto@dees.ufmg.br
<https://orcid.org/0000-0003-2828-0967>

Abstract

The Brazilian federal highway system is largely made up of reinforced concrete (RC) bridges built prior to 1984. Thus, these bridges have incompatible geometry and loading carrying capacity with nowadays traffic. In this scenario, the goal of this investigation was the evaluation of the widening and strengthening procedures used in these RC bridges. The study also includes comparing their performance with the respective new bridges built next to them, which received new highway lanes. This comparison is adequate, considering that, both bridges are inserted in the same environment, are subjected to the same traffic characteristics and have similar spans and structural systems. The results obtained allow us to know the effectiveness of the widening and strengthening interventions carried out, from the point of view of durability, contributing to the improvement of future rehabilitation design for reinforced concrete highway bridges.

Keywords: reinforced concrete highway bridges, strengthening procedures, performance.

Resumo

O sistema rodoviário federal brasileiro é constituído em grande parte por pontes construídas antes de 1984. Assim, essas pontes possuem geometria e capacidade de carga incompatíveis com o tráfego atual. Nesse cenário, o objetivo deste estudo foi a avaliação dos procedimentos de alargamento e reforço empregados em uma ponte de concreto armado que foi reabilitada, visando atender às novas exigências de uma rodovia que foi duplicada. O estudo também inclui a comparação do seu desempenho com a ponte nova, também em concreto armado, que foi construída ao lado para receber a pista nova. Esta comparação se mostra adequada, considerando que ambas as pontes são inseridas no mesmo microclima, estão sujeitas às mesmas características de tráfego e têm vãos e sistemas estruturais semelhantes. Os resultados obtidos permitem conhecer a eficácia das intervenções de alargamento e reforço realizadas, sob o ponto de vista da durabilidade, contribuindo para a melhoria de projetos futuros de reabilitação de pontes rodoviárias de concreto armado.

Palavras-chave: pontes rodoviárias em concreto armado, procedimentos de reforço, desempenho.

^a Federal University of Minas Gerais, MG, Brazil.

1. Introduction

The reinforced concrete (RC) bridges that make up the Brazilian highway system were built from the 1940s, along with the edition of the first Brazilian standards (DNIT [4]). Since then, there has been an evolution of the calculation tools, the materials used in the works, the construction techniques and the vehicles that use the highways, resulting in several updates of standards over time and consequently a very heterogeneous profile of bridges, with different characteristics such as class, geometry, mobile design loads, types of safety barriers and guardrails, which vary according to the construction date.

Considering that the growth of the Brazilian highway system had its apex in the 1960s and 1970s, it is verified that most of the reinforced concrete bridges were built before 1984, that is, they are prior to the validity of the norm NBR-7188 [2] and therefore need strengthening to suit nowadays load carrying capacity.

Currently there is a growing demand for widening and strengthening of reinforced concrete highway bridges. In addition of presenting structural problems (either due to the deterioration of the structure as well as the obsolescence in terms of live loads required by the current design codes), these bridges have also insufficient cross sections for the current traffic demand (Vitório and Barros [12]).

According to a report of the Brazilian Federal Accounting Office (TCU [10]), of a total of 5,612 bridges belonging to the federal road network, 4,105 have lane narrowing problems. In addition, of the 4,739 bridges registered in the Bridges Management System of the National Department of Transport Infrastructure, 261 are in a poor state of conservation and seven in a precarious state of conservation, that is, they require short-term and immediate interventions, respectively (DNIT [6]).

According to Vitório [11], the activities of widening and strengthening of highway bridges began to draw the attention of the Brazilian technical community from the mid-90s, when several works of duplication and / or enlargement of relevant federal and state highways started. These works have shown the need for further studies



Figure 1

Overview of the evaluated bridges. To the left is the rehabilitated bridge and to the right the new bridge

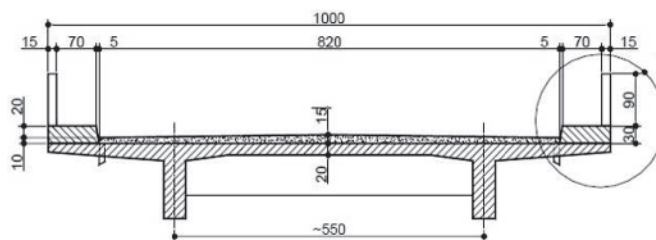

Figure 2

Cross section of the original bridge (dimensions are in centimeters)

on structural interventions in bridges and overpasses. Records of technical and managerial information regarding the performance of interventions that have already been performed do not address properly the aspects of durability. In an investigation by Oliveira [9], some aspects were pointed out in the structural strengthening interventions carried out on RC bridges, which inevitably compromised the durability of the structure and new placed reinforcement. This information is essential to identify problems which should be avoided in strengthening procedures to be carried out in the future. In this scenario, the goal of this investigation was the evaluation of the widening and strengthening procedures used in RC bridges that were rehabilitated, aiming to meet the new requirements of a highway that underwent duplication. The study also includes comparing their performance with the respective new bridges built next to them, which received new highway lanes. This comparison is adequate, considering that, both bridges are inserted in the same environment, are subjected to the same traffic characteristics and have similar spans and structural systems. Surveys in both bridges were executed after the intervention in accordance with the Brazilian current standards. Detailed study of both bridges were conducted including their original design and blueprints, survey reports throughout their service life, strengthening design and procedures as well as a recent evaluation of their performance. The chosen bridges are located over the Pará River on Brazilian highway BR 262 in Nova Serrana, Minas Gerais. Figure 1 shows an overview of these evaluated bridges.

2. Rehabilitated bridge

2.1 Description of the original bridge

The original bridge (class 360 kN) was designed in 1965 by the Brazilian Federal Highway Department - DNER. It was designed according to Brazilian codes: NB-1/1960, NB-2/1960 and NB-6/1960. These codes determined the bridge class, their geometrical characteristics and the live loads to be adopted in bridge design.

This bridge had a length of 230 meters, divided into ten spans of 22 meters and two 5 meters cantilevers at both ends. It had a total width of 10.0 meters (8.20 m roller tracks, with two bearing ranges, wheel guard and body guard). The superstructure is formed by a RC slab over two main beams (Figure 2), simply supported on eleven pairs of columns, and twenty-two transversal beams. The supports have bracing beams at the top and also in the middle and their infrastructure consisted of 22 caissons. The structure of the

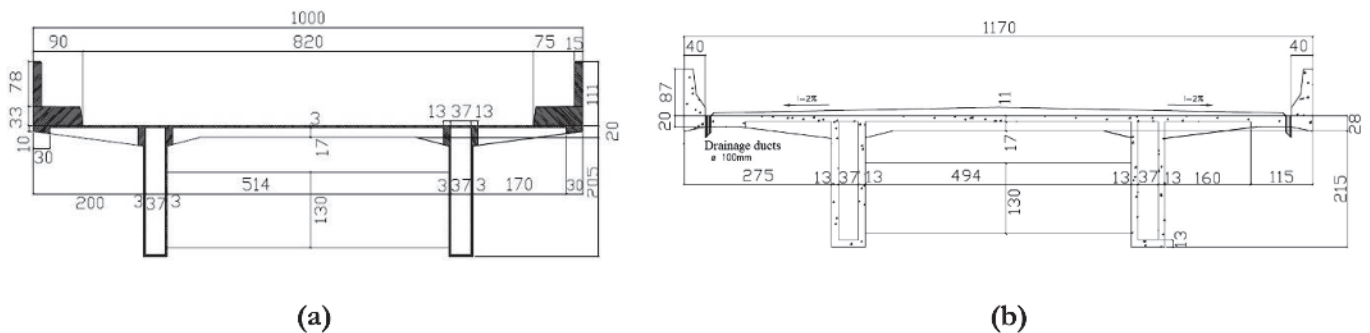

Figure 3
Details of the strengthening procedure. (a) Demolition parts, (b) Formwork and concrete replacement (dimensions are in centimeters)

bridge is further composed of bearing walls at both ends and three expansion joints: two at both ends and one at the middle span. Rubber pads were used on three column lines (1st, 6th and 11th) and lead plates on the other supports.

2.2 Strengthening procedures

The rehabilitation interventions of the bridge were carried out from July 2010 to July 2011 and were aimed at meeting the new requirements of the BR-262 highway that was being duplicated. The design increased the bridge total width from 10.0 to 11.70 meters, which corresponded to two track lanes and shoulder. The bridge was also designed for a live load class of 450 kN. The strengthening procedures also include replacement of support devices, of the pavement, of expansion joints and exchange of wheel guards and guardrails by New Jersey barriers, as well as repairing the concrete where necessary.

The method used for increasing the bridge width consisted of extending the existing slabs at both sides without the addition of new supports and new beams; conventional reinforced concrete was employed. The strengthening of the superstructure was based on the increase of the cross section of the structural elements with addition of new reinforcement (increase in the dimensions of the main beams and addition of new overlay on the slab). Details of these procedures are shown schematically in Figure 3.

The initially design plan included the demolition of the guardrails, of wheel guards and of 30 cm at the ends of the slabs on the sides of the bridge. In addition a 3 cm concrete layer was removed from top surface of the slab and from the faces of the two main beams, aiming to prepare these surfaces for the new repairing concrete. Then, a new 11 cm top slab was cast, along with the new slab with a width of 1.15 m on each side of the bridge (30 cm demolished + 85 cm for the widening). New Jersey barriers and a new 13 cm concrete layer on the faces of the main beams were also cast. The concrete characteristic compressive strength was equal to 30 MPa. Drainage ducts with a diameter of 100 mm were installed on both sides of the bridge.

The column sizes were also increased. The procedure consisted first of the removal of a 3 cm concrete layer of all column sides followed by the placement of additional reinforcement and the casting of a new 13 cm concrete layer. The concrete characteris-

tic compressive strength was equal to 25 MPa. Corbels were also built at the tops of the columns with the objective of supporting the hydraulic jacks that were used for the replacement of the support devices. Mobile 39 mm thick neoprene type pads were installed in all supports: their horizontal dimensions were 35 x 45 cm on the columns at the ends of the bridge and of 45 x 60 cm on the others. Twenty-two new pile caps around each column were built as shown in Figure 4. The concrete characteristic compressive strength was equal to 25 MPa. A deep foundation system consisted of four root-type piles (200 mm diameter) for each pile cap.

In addition to the widening and strengthening interventions, the rehabilitation design consisted of sealing existing cracks at the bottom surface of the slab and repairing the transversal beams and bearing walls where corrosion of the reinforcement was detected. These procedures were intended to treat those locations that did not receive strengthening interventions, but only where they were needed.

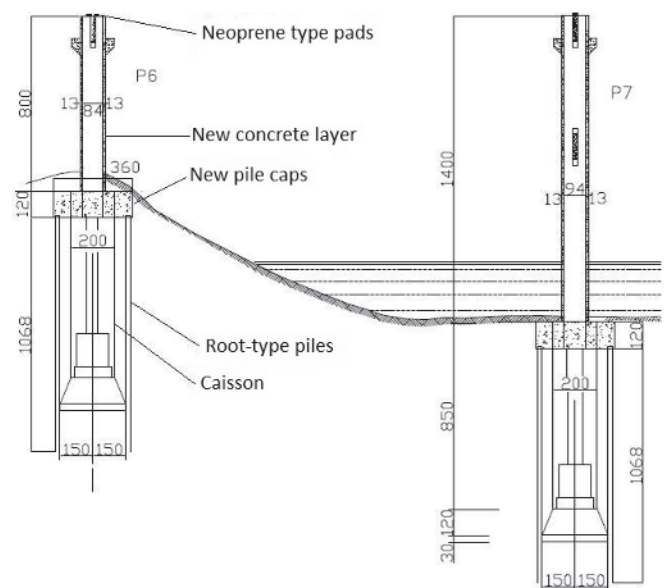

Figure 4
Details of the strengthening of the foundations (dimensions are in centimeters)

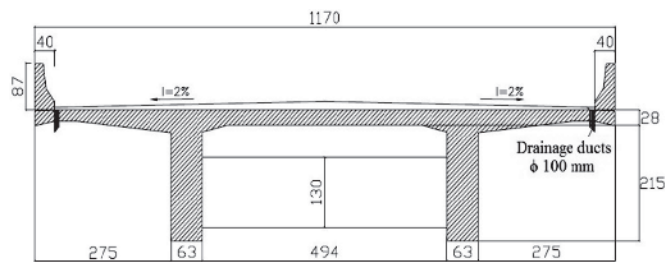

Figure 5
Cross section of the new bridge (dimensions are in centimeters)

3. New bridge

A 450 kN class new bridge was designed in 2006 by DNIT for the duplication of interstate BR-262 highway. Construction of the bridge took place from May 2009 to September 2010. It was then used as a traffic diversion during the rehabilitation of the old bridge and from July 2011, it began to integrate the duplicate interstate highway.

This bridge is also 230 meters in length, and has the same structural system and the same spans of the old bridge. The RC members have the same cross sections of the old bridge elements after the rehabilitation interventions. The concrete characteristic compressive strength was equal to 25 MPa for the foundation elements and 30 MPa for the rest; the specified cover to reinforcement was 3 cm. The bridge foundations in this case consisted of only caissons. Figure 5 shows the cross section with the geometric characteristics of the new bridge.

4. Previous inspections

The first inspections were carried out by the concessionaire Triunfo-Concebra, responsible for this segment of the interstate highway since of March 2014. An initial inspection was carried out on April 11, 2014 and since then routine inspections are performed annually. The main damages identified in these inspections are presented in Table 1.

Table 1

Results of previous inspections of both bridges

Bridge	Year	Identified damages
Rehabilitated	2014	Decreased cross-section of the road; vegetation without maintenance; walkway with debris.
Rehabilitated	2015	Lack of vegetation protection on slopes; infiltrations and problems in the drainage system at the bridge both ends; cracks on wings; deteriorated concrete in safety barriers; maintenance problems in dripping pan and drainage ducts.
Rehabilitated	2016	Deteriorated expansion joints.
New	2014	Decreased cross-section of the road; vegetation without maintenance; walkway with debris.
New	2015	Lack of vegetation protection on slopes; infiltrations and problems in the drainage system at the bridge both ends; cracks on wings; deteriorated concrete in safety barriers; maintenance problems in dripping pan and drainage ducts.
New	2016	Deteriorated expansion joints.

5. Results of the 2017 inspection

The rehabilitated and the new bridge were inspected on June 7, 2017, following the criteria established by NBR 9452 (ABNT [3]) and DNIT 010/2004 - PRO (DNIT [6]). These inspections had the objective of evaluating the current state of the two bridges. The following equipment was employed: tools for cleaning activities and inspection, goggles for improving the vision and measurement devices. In addition to the visual inspection, a pacometer, made by Bosch model D-tect 150 Professional, was used to verify the cover to the reinforcement. The main damages and anomalies identified in each constituent element of the evaluated bridges are presented next.

5.1 Inspection of the rehabilitated bridge

5.1.1 Roller track

According to what had been reported in previous inspections, there is a lane narrowing on the bridge due to the existence of a pedestrian walkway on the place in which, according to the design, there should be the continuity of the shoulder. The pavement on the both bridge accesses shows only minor irregularities and a patch on the expansion joint was executed to correct a small step caused by a settlement. This settlement also caused a vertical misalignment of the safety barrier and sinking of the wings. This in turn led to crushing of the concrete and the exposition of the reinforcement on the left side of the bearing wall. On the right side, although the vertical displacement of the bearing wall had not occurred, it did not resist the weight of the wing, which caused cracking, the disintegration of the concrete and reinforcement exposure. The bearing walls also showed water infiltration points, most likely associated with drainage problems on the both sides of the bridge accesses. Several pathologies were identified in the safety barriers and guardrail, such as cracks, disintegration of the concrete, displacements, stains, and exposed and/or corroded reinforcements. The tests made with the pacometer indicated values of reinforcement covers on the barriers different from the design; this fact that can justify the early emergence of damages related to reinforcement corrosion. The expansion joints were obstructed by the asphalt coating, blocking the free

movement of the superstructure and consequently leading the accumulation of moisture and the deterioration of the sealing material. Moreover, there was accumulation of debris on the roller track close to the expansion joint. Figure 6 shows the conditions of the roller track, including the retaining structure, the drainage system and guardrails.

5.1.2 Superstructure

The main damage that was identified in the super-structure

was the concrete crushing of cantilever slab due to the settlement of the land fill which was not resisted by the bearing wall. There were also damages on the under surface of the slab related to failure in the drainage ducts and dripping pans that were poorly functioning, allowing water percolation through the slab on both cantilever sides. Infiltration stains in places that did not receive repair or strengthening interventions were also found. The presence of water on the under surface of the slab and the infiltrations may lead to leaching, concrete porosity increase and strength reduction which can make it more

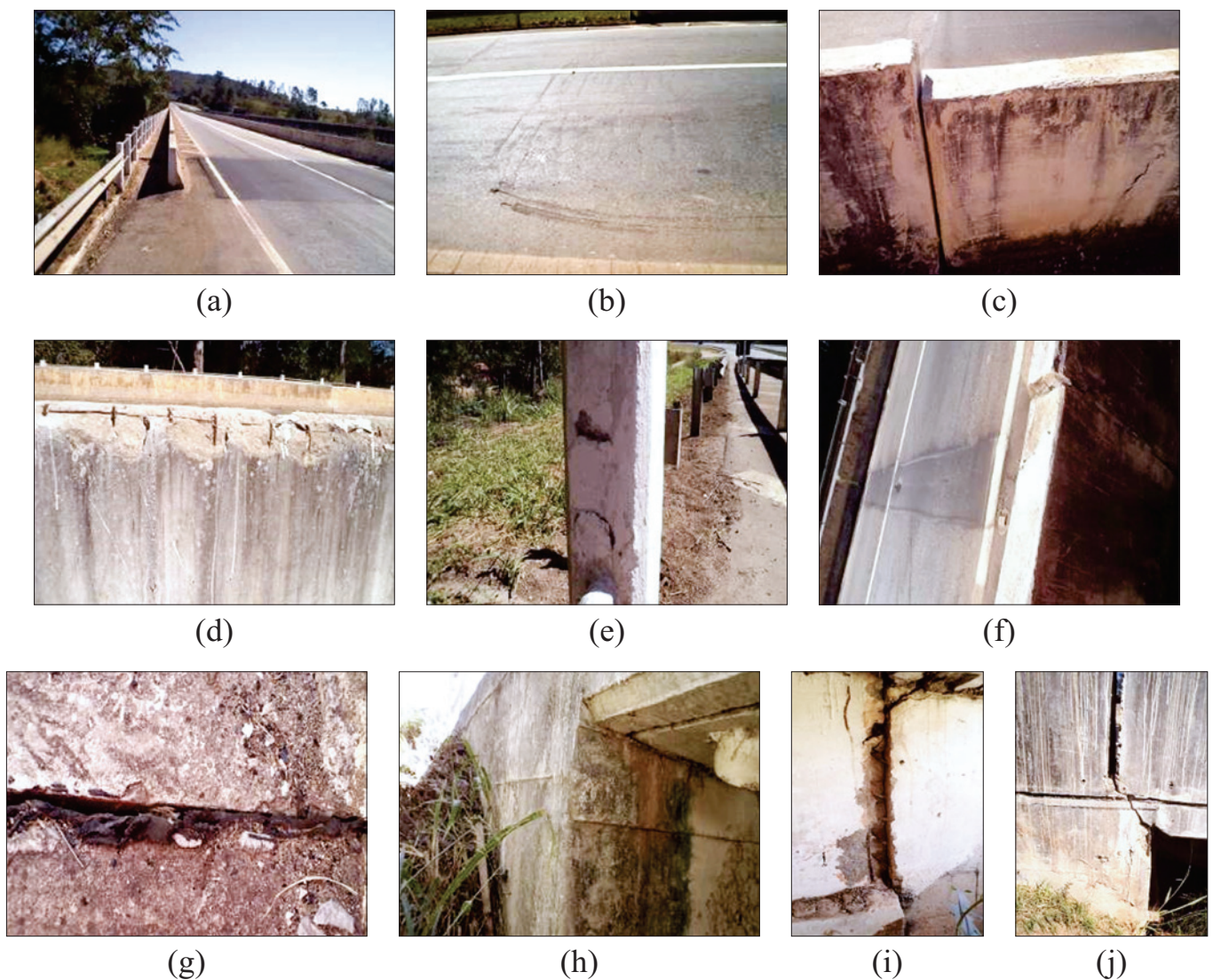

Figure 6

Conditions of the roller track. (a) Lane narrowing on the bridge and patch on the expansion joint, (b) Irregularities in the pavement on the access road, (c) Vertical misalignment of the New Jersey barrier, (d) Disintegration of the concrete and exposed reinforcement on the New Jersey barrier, (e) Reinforcement corrosion on the guardrail, (f) Expansion joint obstructed by the asphalt coating, (g) Deteriorated sealing material at the walkway, (h) Water infiltration points at the bearing wall; (i) Sinking of part of the bearing wall (left side), with crushing of the concrete and the exposition of the reinforcement, (j) Cracking, disintegration of the concrete and reinforcement exposure on the right side of the bearing wall

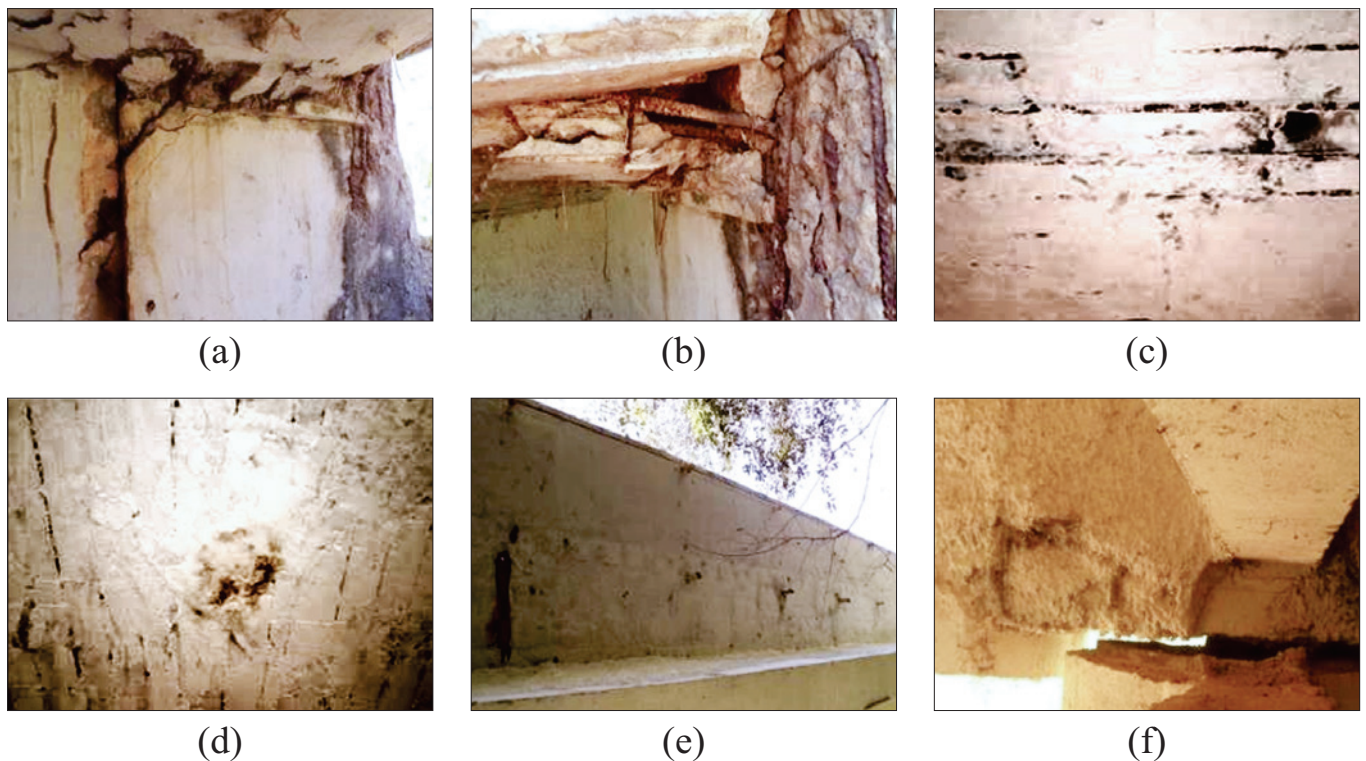

Figure 7

Main damages identified in the superstructure. (a) Concrete rupture of the cantilever slab, (b) Detail of the bended slab with crushing of the concrete and reinforcement exposure, (c) Exposed reinforcement on the under surface of the slab, (d) Infiltration stains at the bottom surface of the slab (e) Damaged drainage ducts, allowing water percolation through the slab, (f) Localized concrete casting voids were noticed on the under surface of retrofitted main beams with exposed reinforcement

vulnerable (HELENE [7]). Localized concrete casting voids were noticed on the under surface of retrofitted main beams next to the support columns. The measurements made with the pacometer showed insufficient concrete cover on the transversal beams and the slab, including the retrofitted parts of these elements. These aspects are shown in Figure 7.

5.1.3 Mesostructure

The mesostructure is in good condition of preservation. Only a few localized concrete casting voids in retrofitted columns have been identified; but they did not cause any type of structural deficiency. Signs of water infiltration in the sixth line of columns were noticed



Figure 8

Damages identified in the mesostructure. (a) Signs of water infiltration in the columns and transversal beam, due to failures in the sealing of the expansion joint (b) Exposed reinforcement in the column strengthening

due to failures in the sealing of the expansion joint. These damages are shown in Figure 8.

5.1.4 Infrastructure

The most relevant identified anomalies in this bridge are in the new and strengthened elements of the foundation. The pile caps and part of the root-type piles were executed above water level, different from the design, which prescribed buried piles. This pile position compromises their durability and also reduces the contribution of lateral friction in increasing the load carrying capacity of the foundation. Major execution problems were visible at the top of the root type piles: significant reduction of their cross section dimensions due to the presence of concreting honeycombs or due to disintegration of concrete associated with the poor quality of the material. Failures in the bonding of the pile caps with the root-type piles prevent the strengthened elements to resist additional load and effectively contribute to the increase in the load carrying capacity of the foundation. Only the old caissons are bearing the bridge's increased load. There was no vegetation protection on the slopes which led to signs of erosion that needed correction to avoid the future occurrence of any kind of instability in the foundation or retaining structures of the roller track. Figure 9 illustrates these aspects.

5.2 Inspection of the new bridge

5.2.1 Roller track

The new bridge presents lane narrowing for the same reasons as the old bridge. The pavement was in good conditions, having presented only a few deviations on the road accesses to the bridge. Settlement of the land fill of both accesses could also be observed, resulting in vertical misalignment of the safety barrier. Safety barriers and guardrail showed several pathologies most likely associated with the insufficient thickness of reinforcement cover. The expansion joints located at the ends of the bridge were completely obstructed by the asphalt coating. The joint located in the middle of the bridge, although unobstructed, also showed problems in the sealing due to deterioration of its filling material. There was a hole on the floor of the walkway caused by the settlement of the land fill at the exit of the bridge, which crushed the concrete on that part. The bearing walls presented water infiltration points most likely associated with malfunctioning of the drainage system. Figure 10 shows these conditions.

5.2.2 Superstructure

The main pathological problems identified in the structure were

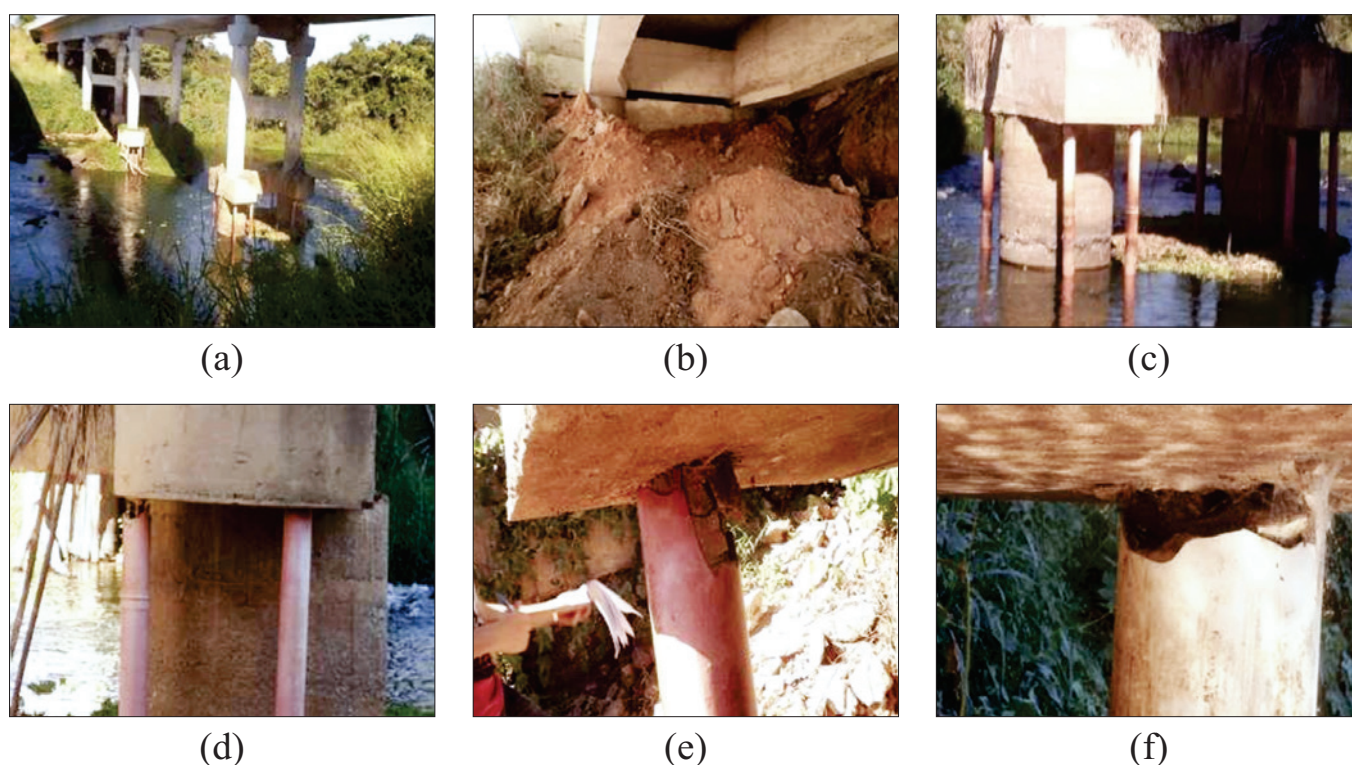

Figure 9

Main problems related to infrastructure. (a) Exposed pile caps and part of the root-type piles, (b) Signs of erosion and lack of vegetation protection on the slope, (c) Damages at the top of the root-type piles, (d) Lack of concrete at the top of the pile in which the cap rests, (e) Disintegration of concrete at the top of the pile, (f) Concreting voids at the top of the pile

related to the drainage system, which was not efficient. There were some infiltration stains in the gaps of the slab and in one transversal beam caused by rupture of the sealing material in one of the expansion joints. Reinforcement was exposed on the top surface of the slab of the walkway. The main beams showed cracks on their lateral faces due to bending, but the openings were within acceptable levels according to norm NBR 6118 (ABNT [1]). The results of the pacometer tests showed insufficient concrete in the slab and in main and transversal beams. These aspects are illustrated in Figure 11.

5.2.3 Mesostructure

In general, the elements of the mesostructure were in good conditions. Some signs of infiltration caused by rupture of the sealing material were identified in the bracing beam that connects the columns located below the expansion joint (Figure 12 a). The supporting devices were obstructed by styrofoam and mortar residues compromising their optimal performance (Figure 12 b). Reinforcement cover was smaller than prescribed by design.

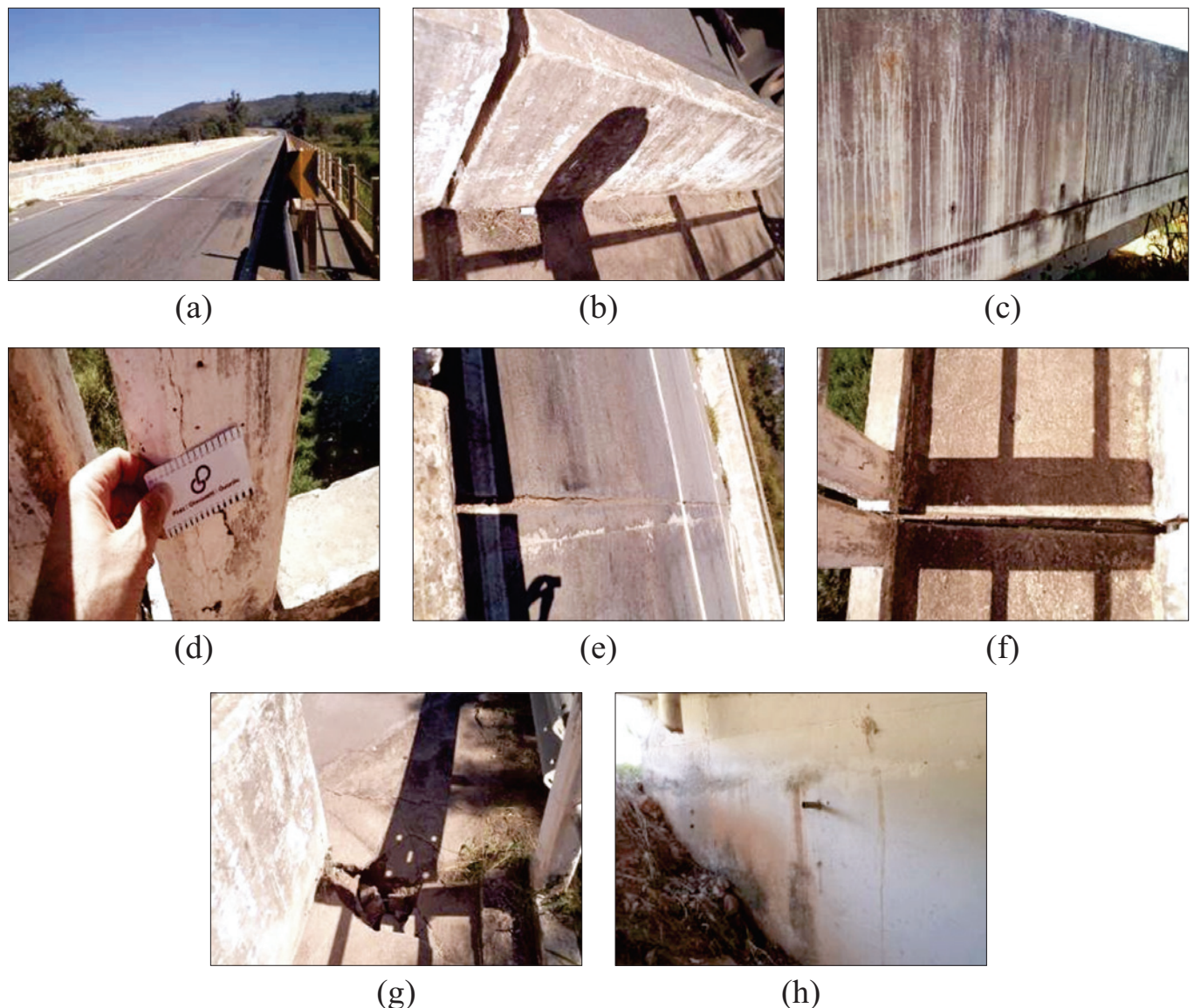

Figure 10

Conditions of the roller track. (a) Lane narrowing on the bridge, (b) Vertical misalignment of the New Jersey barrier, (c) Infiltration stains on the New Jersey barrier, (d) Cracking with opening of 0.4 mm in the guardrail due to reinforcement corrosion, (e) Expansion joint obstructed by the asphalt coating, (f) Deteriorated sealing material at the walkway, (g) Hole on the floor of the walkway, caused by the settlement of the land fill, (h) Water infiltration points on the bearing wall

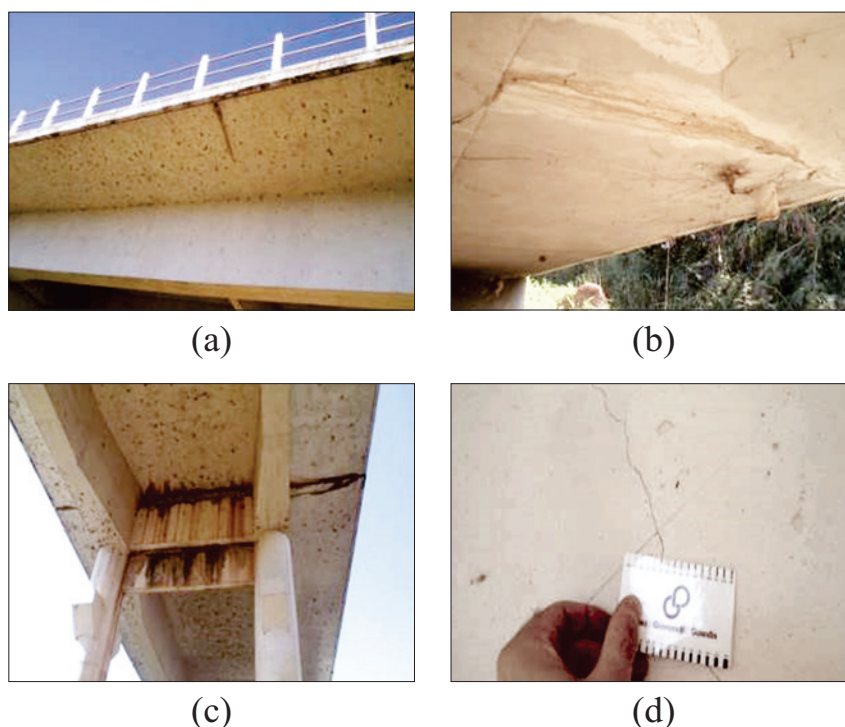

Figure 11

Main damages identified in the superstructure. (a) Malfunctioning of the dripping pan, (b) Malfunctioning of drainage ducts and of the dripping pan, (c) Infiltration stains in the slab and in one transversal beam, caused by rupture in the sealing material in one of the expansion joints, (d) Cracking with a maximum opening of 0.3 mm at the lateral side of the main beams

5.2.4 Infrastructure

Despite its largest part not being visible, it is assumed that the infrastructure is in good state of preservation since there was no sign of consolidation or displacement of the foundation. Only the absence of vegetation protection on the slopes and some minor erosions caused by bad positioning of some drainage ducts that direct rain water to the exit of the land fill were observed (Figure 13).

5.3 Comparative analysis of the inspection evaluation

In general, the new bridge had a satisfactory performance: no significant damage that may affect the stability of the construction was detected. As for the rehabilitated bridge, its performance was subpar, with several damages or anomalies that may compromise not only its structural safety but also its long-term durability. Figure 14 shows a chart with the technical grades attributed to



Figure 12

Main damages found in the mesostructure. (a) Infiltration stains on the bracing beam of the columns located below the expansion joint, (b) Presence of mortar residues around the support device

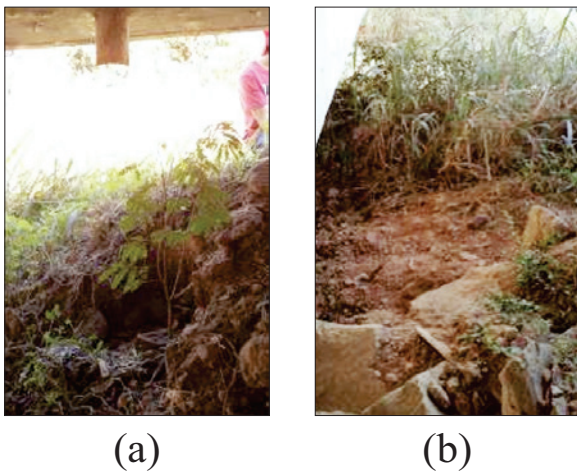

Figure 13
Main damages identified in the infrastructure. (a) Minor erosion on the slope caused by bad positioning of drainage duct, (c) Another erosion on the slope

each bridge, in accordance to the criteria established by Brazilian standard NBR 9452 (ABNT [3]).

The smaller technical grades of the rehabilitated bridge, related to structural and durability aspects, are due to deficient performance of the new and retrofitted concrete elements. The poor conditions of the rehabilitated bridge's safety barriers interfered on its technical grade according to the functionality behavior. The existence of cracks in the main beams and erosions located on the slopes of both bridge accesses were the most influential aspects in the evaluation of the new bridge. According to the results, correction of the anomalies that cause structural insufficiency and affect the long-term durability of the rehabilitated bridge should be the short term actions to be taken. The medium term actions correspond to the correction of problems that affect its functionality. For the new bridge, monitoring the cracks in the main beams of the new is recommended as a medium term measure; correction of the erosions on the slope may also be necessary.

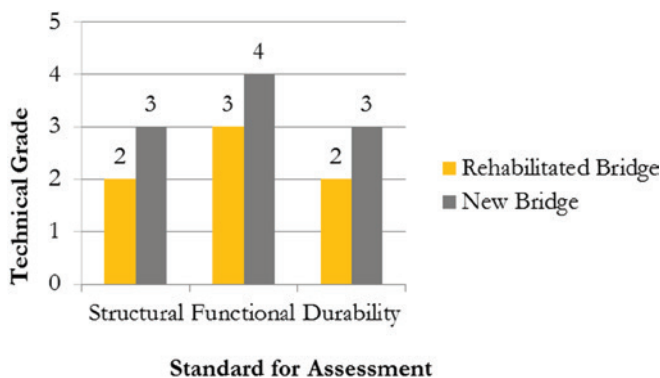

Figure 14
Technical grades attributed to each bridge

6. Conclusions

The main damages identified in the rehabilitated bridge are located in the strengthened foundation elements and in both bridge access (with consequences on the performance of the wings, bearing wall and slab). These problems are related to deficient retrofitting execution procedures and to the absence of a repair design for the structural elements that did not need strengthening.

Considering the problems identified in the widening and strengthening interventions, and the narrow scope of the repair design, it can be concluded that the rehabilitation of the bridge was not effective in this case. Besides ensuring the geometrical and load carrying capacity readjustment, the rehabilitation procedures should have provided an increase on the service life performance of all elements that compose the bridge. These aspects make the early emergence of aforementioned problems unacceptable.

The occurrence of common damages in both bridges was also verified. The drainage system proved to be inefficient, not being able to collect rainwater from the road and protect the superstructure of the bridges. According to Mehta and Monteiro [8], water is a key factor when it comes to durability issues with the concrete structures since it may cause its degradation by physical and/or chemical processes, besides corrosion of the embed reinforcement. The new concrete elements, such as New Jersey barriers and guardrails do not present adequate performance due to insufficient reinforcement cover, in disagreement with the design. The expansion joints are obstructed by the asphalt coating, compromising its optimal performance and the durability of the structure as a whole. The absence of the design for pedestrian walkways resulted in the narrowing of both bridges, compromising the safety of the road's users.

Maintenance activities have a fundamental role in the long-term durability of reinforced concrete bridges (DNIT [5]). This study indicates that the maintenance on both inspected bridges deserves more attention since they will ensure safety and comfort the users through the execution of cleaning activities on the road as well as minor correction procedures such as rehabilitation of the drainage system devices. They have low cost and big impact on the long-term durability of the structure.

The analysis of the data collected during the inspections and the level of deterioration of each evaluated bridge show that the rehabilitated bridge had a much inferior performance when compared to the new bridge that was built next to it. However, the main anomalies that were identified are related to major retrofitting execution problems that could have been avoided with a more rigorous quality control during that the rehabilitation construction phase of the old bridge. So, in spite of the result found in this particularly bridge when compared to a new one, repairing and strengthening procedures of old reinforced concrete bridges to meet nowadays traffic demands is still a viable solution.

7. References

- [1] ASSOCIAÇÃO BRASILEIRA DE NORMAS TÉCNICAS – ABNT, 2014. NBR 6118: Projeto de estruturas de concreto - Procedimento. Rio de Janeiro.

- [2] ____, 1984. NBR 7188: Carga móvel em ponte rodoviária e passarela de pedestre. Rio de Janeiro.
- [3] ____, 2016. NBR 9452: Inspeção de pontes, viadutos e passarelas de concreto. Rio de Janeiro.
- [4] DEPARTAMENTO NACIONAL DE INFRAESTRUTURA DE TRANSPORTES – DNIT, 2004a. Manual de Inspeção de Pontes rodoviárias. Rio de Janeiro.
- [5] ____, 2010. Manual de Recuperação de Pontes e Viadutos Rodoviários. Rio de Janeiro.
- [6] ____, 2004b. Norma DNIT 010/2004 – PRO – Inspeções em pontes e viadutos de concreto armado e protendido - Procedimento. Rio de Janeiro.
- [7] HELENE, Paulo (ed.), 2003. Manual de Reabilitação de Estruturas de Concreto: Reparo, Reforço e Proteção. Red Reabilitar, São Paulo.
- [8] MEHTA, P. Kumar; MONTEIRO, Paulo J. M., 1994. Concreto, microestrutura, propriedades e materiais. Tradução: Antônio Carmona Filho et al. São Paulo: PINI.
- [9] OLIVEIRA, C.B.L., 2013. Análise da eficácia de métodos de reforço de pontes rodoviárias de concreto armado. Dissertação – Curso de Pós-Graduação em Construção Civil, Universidade Federal de Minas Gerais, Belo Horizonte, MG.
- [10] TRIBUNAL DE CONTAS DA UNIÃO – TCU, 2012. Acórdão 725/2012– Plenário. Brasília.
- [11] VITÓRIO, J.A.P., 2013. Um estudo comparativo sobre métodos de alargamento de pontes rodoviárias de concreto armado, com a utilização das normas brasileiras e eurocódigos. Tese de doutorado na Universidade do Porto, Portugal.
- [12] VITÓRIO, J.A.P.; BARROS, R.M.M.C., 2014. A utilização do Eurocódigo em Projetos de Alargamento e Reforço de Pontes Rodoviárias de Concreto. VII Congresso Brasileiro de Pontes e Estruturas. Rio de Janeiro, RJ.